



Tischkultur. Genuss. Erlebnis.
Dining Culture. Pleasure. Experience.

WMF Professional
Gesamtprogramm | Complete Range 2017/2018



Tischkultur. Genuss. Erlebnis.

Dining Culture. Pleasure. Experience.

Alles für das perfekte Genuss-Erlebnis.

Everything for the perfect
sense experience.

„Tischkultur. Genuss. Erlebnis.“ – Das ist die Quintessenz von WMF Professional. Mit unserer Expertise rund um den gedeckten Tisch vervollständigen wir die Sinneseindrücke Ihrer Gäste: Während Sie den einzigartigen Geschmack und Duft eines Menüs kreieren, schlagen wir mit stilvollem Glas, Besteck und Porzellan die Brücke zu Ästhetik und Haptik. Für jedes gastronomische Konzept bieten wir die passenden Akzente: ob gehoben, rustikal, mediterran, minimalistisch oder avantgardistisch.

Unser kreativer Kosmos reicht von formschönen Bestecken und Gläsern über hochwertige Tabletop-Kollektionen bis zu flexiblen Buffet-Systemen – allen voran die neueste Kreation im Bereich der Buffet-präsentation: WMF Quadro. Ein Buffetsystem in Ihrem Takt. Freuen Sie sich mit uns auf ein spannendes neues Jahr und genießen Sie die Erlebniswelten von WMF Professional.

“Table culture. Pleasure. Experience.” – this is the quintessence of WMF Professional. We complement your guests' sensory impressions through our expertise in creating the perfectly laid table. While you create the unique taste and aroma of your menu, we provide the essentials for a great look and feel with stylish glassware, cutlery and porcelain. We offer suitable highlights for all gastronomic concepts, whether sophisticated, rustic, mediterranean, minimalist or avantgarde.

Our creative cosmos ranges from elegant cutlery and glassware to high-quality table top collections and flexible buffet systems – most notably the newest invention in the buffet presentation range WMF Quadro. A buffet system to your own beat. Look forward to an exciting new year with us and enjoy the world of experience of WMF Professional.



Alexander Pick
Head of Sales WMF
Business Unit Hotel



Christoph Berscheid
Leiter Vertrieb Deutschland
WMF GastroProfi



Alexander Pick und Christoph Berscheid

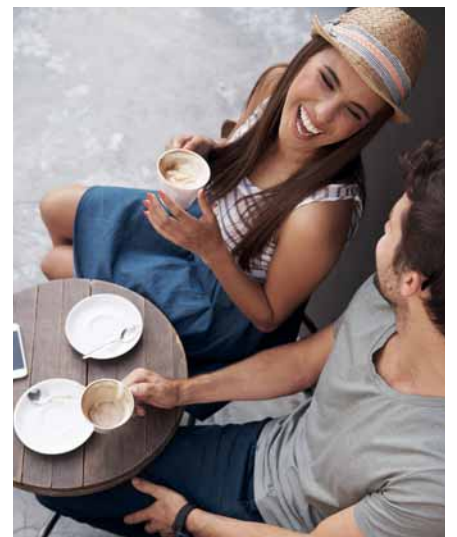

Leidenschaft für Tischkultur.
Made in Geislingen.

Passion for table culture.
Made in Geislingen.



Bestecke, Table Top und Buffet Elemente – alle WMF Produkte sind Ausdruck unserer Leidenschaft für Tischkultur. Sie sind hochwertige, perfekt verarbeitete Werkzeuge, die Sinne anregen, Geschmackserlebnisse steigern und das Ambiente zum Glänzen bringen. Sie transportieren von weltweit 40 Standorten aus unsere Philosophie: Ihr Gastronomiekonzept auf den Punkt und auf den Tisch zu bringen.

Tischkultur ist ständig in Bewegung. Sie lebt vom Gespür für den Moment. Für den perfekten Augenblick, in dem alles stimmig ist. Dahinter steht die Expertise und Zuverlässigkeit von WMF mit klar aufeinander abgestimmten Arbeitsprozessen in Forschung, Design, Entwicklung und Fertigung. Aus unserem vielfältigen Produktportfolio entstehen innovative, ganzheitlich abgestimmte Lösungen aus einer Hand. Für Ihren individuellen Stil. Für formvollendete Funktionalität, Präzision und Beständigkeit, die sich im Gastronomiealltag bewähren – seit 1853.

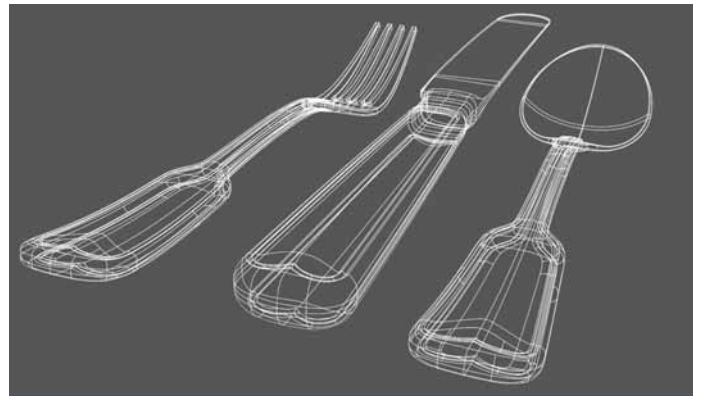
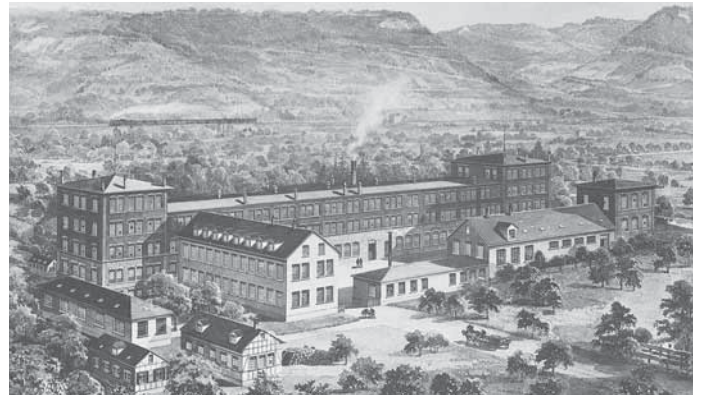

Cutlery, table top and buffet wares – all WMF products are expressions of our passion for table culture. They are high-quality, perfectly crafted implements that stimulate the senses, enhance taste experiences and add sparkle to ambience. From 40 locations worldwide they impart our philosophy: expression for your gastronomic concept and its presentation on the table.

Table culture is constantly in motion. It thrives in the feeling for the moment. For that perfect instant, when everything is exactly right. Brought about with the expertise and dependability of WMF and our finely tuned workflows in research, design, development and production. Innovative, totally harmonised, single-source solutions come from within our extensive product portfolio. For your individual style. For form-perfect functionality, precision and lasting good appearance tried and tested in the daily routines of gastronomy and catering – since 1853.



Glanzstücke mit Geschichte: Die Kunst der Reparatur-Werkstatt von WMF.

Showpieces with a history:
taken care of by our WMF repair service.



Was heute die qualitative Hochwertigkeit der Produkte von WMF ausmacht, findet seine Ursprünge in der traditionellen Handwerkskunst. Daher ist es für uns auch nach über 160 Jahren Unternehmensgeschichte selbstverständlich, Werkzeug und Hand anzulegen, um ein Produkt aufzuarbeiten oder individuell zu verschönern. Die besondere Expertise der WMF Reparatur-Werkstatt reicht in alle verarbeitenden Edelmetallkünste hinein: vom Ausbeulen, Löten und Schweißen über die Versilberung, das Vergolden sowie den Austausch von Knöpfen und Griffen bis hin zur Umsetzung kundenindividueller Design-Ansprüche.

Mit Hingabe und Detailverliebtheit versetzen wir seltene und lieb gewonnene Stücke wieder in ihren ursprünglichen Zustand. Dieses Werteverständnis pflegt WMF seit jeher – lange bevor die Begriffe Nachhaltigkeit oder Vintage zum Trend wurden. Der Service ist in der Branche etabliert und geschätzt: Beispielsweise arbeiteten wir für den letzten Auftrag des Bundespräsidialamtes knapp 900 Besteckteile auf – denn dort deckt man den Tisch für Gäste bereits seit rund 60 Jahren mit WMF in Silber. Einen weiteren Weg haben mehrere Rinderbrustwagen aus

Madeira zurückgelegt. Nach jahrzehntelangem Einsatz im Belmond Reid's Palace kamen sie schließlich zur originalgetreuen Aufarbeitung in die Werkstatt von WMF. Bei solch sensiblen, historischen Stücken ist die professionelle Aufbereitung oft die letzte Rettung. Diese Tatsache weckt die Leidenschaft unserer Mitarbeiter, ein Stück Geschichte zu wahren.

The high quality that is characteristic of WMF products today has its roots embedded in traditional craftsmanship. This is why, even after our company history that dates back over 160 years, it is second nature for us to use our hands and tools to recondition products or to individually embellish them. The specialist expertise at the WMF repair service covers all processed precious metal arts: from flattening, soldering and welding through to silverplating, goldplating and changing handles and buttons to meet customer-specific design demands.

With devotion and a love for detail, we restore rare and treasured pieces back to their original condition. WMF has always had this understanding of values – long before

the terms sustainable and vintage became trendy. The service is established and valued within the sector: For example, as part of the recent order from the German Presidential Office, we restored nearly 900 pieces of cutlery – since for the last 60 years its table has been laid for guests using WMF silver. A number of roast beef serving trolleys have also travelled a long way from Madeira. After decades of use at Belmond Reid's Palace, they finally arrived at the WMF workshop to be restored to their former glory. With such delicate, historical pieces, professional restoration is often the last hope. This fact awakens the passion of our employees who enjoy preserving a piece of history.



Inhalt

contents



Besteckkollektionen flatware collections

Besteck ist nicht gleich Besteck.
Cutlery is not just cutlery.

Besteckkollektionen
flatware collections

Besteck Ergänzungsteile
neutral serving pieces

Besteck-Veredelungen
cutlery finishing techniques

Table Top table top

Mix & Match par excellence.
Mix & match through excellence.

Tee & Kaffee
tea & coffee

Weinkühler & Ständer
wine cooler & stands

Serviergeräte
serving utensils

Diverses
miscellaneous

Körbe & Schalen
baskets & bowls

Kerzen & Leuchter
candles & lamps

Vasen
vases

Mühlen & Menagen
grinding & condiment sets

WMF firstglass

Ausstattung & Interieur
fittings & interior

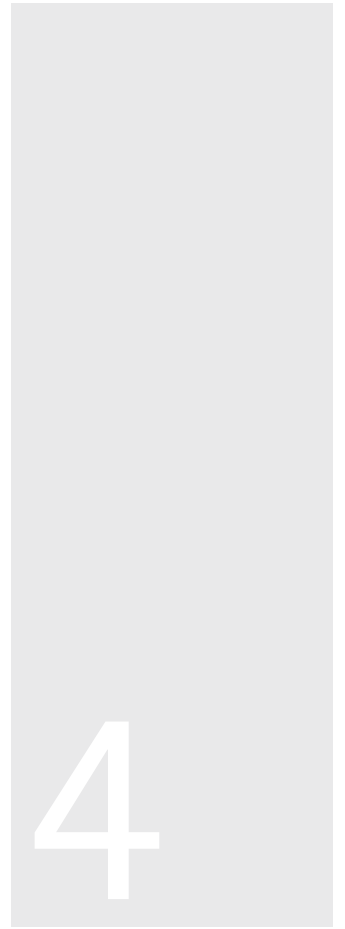

3

4

Buffet buffet

Gesamt-Inhaltsverzeichnis alphabetical index

Buffet in Ihrem Takt.
Buffet to your own beat.

Blick hinter die Kulissen.
Produktdesigner Peter Ramminger.
Behind the scenes.
Product designer Peter Ramminger.

WMF Quadro

Chaving Dishes Induktion
chaving dishes induction

Chaving Dishes

Chaving Dish Zubehör
chaving dish accessories

Coffee Urns

Dispenser

Getränkekühler
beverage cooler

Etagéren
etageres

Plattenständer
tray stands

Platten & Tablett
platters & trays

Pflegemittel
cleaning aids

A – Z

Besteckkollektionen

flatware collections







Besteck ist nicht gleich Besteck: Für jeden Look die passende Begleitung

Cutlery is not just cutlery:
the ideal accompaniment for every look

Als aufmerksamkeitsstarkes Detail auf dem gedeckten Tisch unterstreicht Besteck den individuellen Charakter Ihres gastronomischen Konzepts – entweder durch dezente Zurückhaltung oder optische Prägnanz. Dabei richtet sich die Auswahl des passenden Modells immer nach der Architektur, dem Interieur und der Speisekarte Ihres Hauses: von gehoben über rustikal oder mediterran bis hin zu minimalistisch und avantgardistisch. Welche Stilrichtung Sie auch verfolgen: Die passenden Formen, Farben und Strukturen finden Sie in der vielfältigen Besteckwelt von WMF Professional.

Die WMF Designer verfolgen bei der Kreation einer neuen Kollektion stets den Anspruch, Ästhetik, Haptik und Funktionalität in harmonischen Einklang zu bringen. Denn nicht nur der Look macht ein qualitativ hochwertiges Besteck aus, es muss auch angenehm in der Hand liegen, robust sowie langlebig sein. Während der Entwicklung orientieren wir uns nicht nur an klassischen Stilrichtungen, sondern berücksichtigen auch aktuelle Trends und das Feedback unserer Kunden. Auf diese Weise entstand in den vergangenen Jahrzehnten ein vielseitiges Portfolio, mit dem wir Ihre ganz persönlichen Designansprüche abbilden können.



A striking detail on the laid table, cutlery emphasises the individual character of your gastronomic concept – either through discreet restraint or visual conciseness. The choice of the ideal model is always based on the architecture, the interior design and the menu: from sophisticated or rustic to mediterranean, minimalist or avantgarde. Whatever your style, you will find the ideal shapes, colors and structures in the diverse cutlery world of WMF Professional.

When creating a new collection, the WMF designers always aim to strike a harmonious balance between the demand for aesthetics, feel and functionality. It is not simply the look of a cutlery that makes it high quality, it must also sit pleasantly in the hand, be robust and long-lasting. During the development stage, we focus upon classic styles, but we also take current trends and feedback from our customers into account. Over the past decades, this approach has enabled us to create a diverse portfolio that we can use to meet your own personal design demands.

Besteckkollektionen

flatware collections



TRIOMPHE 2000

■ ■
Seite 16 | page 16



BAROCK 3000

■ ■
Seite 20 | page 20



JUWEL 7300

■ ■
Seite 24 | page 24



NORDIC 7200

■ ■
Seite 28 | page 28



BASE 2300

■
Seite 44 | page 44



UNIC 5300

■ ■
Seite 48 | page 48



GASTRO 0800

■
Seite 52 | page 52



SIGNUM 1900

■ ■
Seite 56 | page 56



CLUB 4700

■
Seite 72 | page 72



BAGUETTE 0100

■ ■
Seite 76 | page 76



MONDIAL 6200

■ ■
Seite 80 | page 80



RESIDENCE 4800

■ ■
Seite 84 | page 84



TELOS 1800

■
Seite 32 | page 32



CASINO 9000

■ ■
Seite 36 | page 36



SOLID 7900

■ ■
Seite 40 | page 40



CONTOUR 0200

■ ■
Seite 60 | page 60



BISTRO 0400

■ ■
Seite 64 | page 64



FLAIR 1100

■ ■
Seite 68 | page 68



METROPOLITAN 5400

■ ■
Seite 88 | page 88



**Besteck für
magnetische
Abnahme**

Cutlery for
magnetic removal

Mehr Informationen
More information
wmf-professional.de

■ perfekt versilbert
perfectly silver-plated

■ Cromargan®, poliert
Cromargan®, polished





Exklusiv.
Exclusive.

Auffallend.
Eye-catching.

Elegant.
Elegant.

TRIOMPHE

■ 54.2001.6030

Menuelöffel

215 mm/8½ in.
table spoon
cuiller de table
cuchara mesa
cucchiaio tavola



■ 54.2002.6030

Menuegabel

214 mm/8½ in.
table fork
fourchette de table
tenedor mesa
forchetta tavola



■ 54.2003.6037

Menuemesser*

248 mm/9¾ in.
table knife*
couteau de table*
cuchillo mesa*
coltello tavola cutinato*



■ 54.2003.6039

Menuemesser**

248 mm/9¾ in.
table knife**
couteau de table**
cuchillo mesa**
coltello tavola cutinato**



■ 54.2004.6030

Vorspeisenlöffel

196 mm/7½ in.
dessert spoon
cuiller à dessert
cuchara postre
cucchiaio frutta



■ 54.2005.6030

Vorspeisengabel

195 mm/7½ in.
dessert fork
fourchette à dessert
tenedor postre
forchetta frutta



■ 54.2006.6037

**Vorspeisen-
messer***

226 mm/9 in.
dessert knife*
couteau à dessert*
cuchillo postre*
coltello frutta*



■ 54.2006.6039

**Vorspeisen-
messer****

226 mm/9 in.
dessert knife**
couteau à dessert**
cuchillo postre**
coltello frutta**



■ 54.2007.6030

Kaffeelöffel

136 mm/5½ in.
tea/coffee spoon
cuiller à café
cuchara café
cucchiaio caffè/té



■ 54.2009.6030

**Espresso- /
Mokkalöffel**

108 mm/4½ in.
demi-tasse spoon
cuiller à mocca
cuchara moca
cucchiaio moca



■ 54.2010.6030

**Vorspeisen- /
Dessertlöffel**

156 mm/6¼ in.
coffee/tea spoon, large
cuiller à café/thé, grande
cuchara à café/té, grande
cucchiaio caffè/té, grande



■ 54.2011.6030

Gourmetlöffel

196 mm/7¾ in.
gourmet spoon
cuiller à sauce
cuchara gourmet
cucchiaio gourmet



■ 54.2035.6030

Fischgabel

190 mm/7½ in.
fish fork
fourchette à poisson
tenedor pescado
forchetta pesce



■ 54.2036.6030

Fischmesser

215 mm/8½ in.
fish knife
couteau à poisson
cuchillo pescado
coltello pesce



■ 54.2040.6030

Austerngabel

149 mm/6 in.
oyster fork
fourchette à huîtres
tenedor ostras
forchetta per ostriche



■ 54.2064.6030

Kuchengabel

157 mm/6¼ in.
cake fork
fourchette à gâteau
tenedor lunch
forchetta per dolce



■ 54.2066.6039

**Brot- /
Buttermesser****

170 mm/6½ in.
bread/butter knife**
couteau de table**
cuchillo lunch**
coltello per dolce**



■ 54.2072.6030

Limolöffel

220 mm/8½ in.
iced tea spoon
cuiller à soda
cuchara refresco
cucchiaio bibita



■ 54.2078.6039

Steakmesser**

247 mm/9¾ in.
steak knife**
couteau à steak**
cuchillo steak**
coltello da bistecca**



■ 54.2089.6030

Tassenlöffel

174 mm/7 in.
round bowl soup spoon
cuiller à bouillon
cuchara sopa
cucchiaio da brodo



VPE 12 Stk. / Unit 12 pcs.

- perfekte Versilberung / perfectly silverplated
- Cromargan®, poliert / stainless 18/10, polished

* Hohlheft mit Wellenschliff / hollow-handled with serrated edge

** Klingenstahl mit Wellenschliff / monobloc with serrated edge



■ **54 2000 6030**
 perfekt versilbert
 perfectly silverplated
 chromage parfait
 plateado perfecto
 perfetta placcatura in argento

■ **54 2000 6040**
 Cromargan®, poliert
 Cromargan®, polished
 Cromargan®, poli
 Cromargan®, pulido
 Cromargan®, lucido

Triomphe verleiht dem klassischen Besteckmuster „Augsburger Faden“ modernen Zeitgeist. In Kombination mit feiner Tischwäsche und edlem Porzellan ist das Modell der Glanzpunkt auf dem gedeckten Tisch.

Triomphe gives the classic “Augsburger Faden” cutlery design a modern twist. Combined with fine table linen and elegant porcelain, this collection is a sparkling focal point of any well-laid table.

TRIOMPHE
 2000





Fürstlich.
Regal.

Edel.
Noble.

Traditionell.
Traditional.

BAROCK

■ 54.3001.6030
■ 54.3001.6040

Menuelöffel
213 mm/8½ in.
table spoon
cuiller de table
cuchara mesa
cucchiaio tavola



■ 54.3002.6030
■ 54.3002.6040

Menuegabel
212 mm/8½ in.
table fork
fourchette de table
tenedor mesa
forchetta tavola



■ 54.3003.6037
■ 54.3003.6047

Menuemesser*
235 mm/9½ in.
table knife*
couteau de table*
cuchillo mesa*
coltello tavola cutinato*



■ 54.3003.6039
■ 54.3003.6049

Menuemesser**
235 mm/9½ in.
table knife**
couteau de table**
cuchillo mesa**
coltello tavola cutinato**



■ 54.3004.6030
■ 54.3004.6040

Vorspeisenlöffel
196 mm/7¾ in.
dessert spoon
cuiller à dessert
cuchara postre
cucchiaio frutta



■ 54.3005.6030
■ 54.3005.6040

Vorspeisengabel
195 mm/7¾ in.
dessert fork
fourchette à dessert
tenedor postre
forchetta frutta



■ 54.3006.6037
■ 54.3006.6047

**Vorspeisen-
messer***
217 mm/8½ in.
dessert knife*
couteau à dessert*
cuchillo postre*
coltello frutta*



■ 54.3006.6039
■ 54.3006.6049

**Vorspeisen-
messer****
217 mm/8½ in.
dessert knife**
couteau à dessert**
cuchillo postre**
coltello frutta**



■ 54.3007.6030
■ 54.3007.6040

Kaffeelöffel
136 mm/5½ in.
tea/coffee spoon
cuiller à café
cuchara café
cucchiaio caffè/té



■ 54.3009.6030
■ 54.3009.6040

**Espresso- /
Mokkalöffel**
108 mm/4½ in.
demi-tasse spoon
cuiller à mocca
cuchara moca
cucchiaio moca



■ 54.3010.6030
■ 54.3010.6040

**Vorspeisen- /
Dessertlöffel**
156 mm/6¼ in.
coffee/tea spoon, large
cuiller à café/thé, grande
cuchara à café/té, grande
cucchiaio caffè/té, grande



■ 54.3011.6030
■ 54.3011.6040

Gourmetlöffel
194 mm/7¾ in.
gourmet spoon
cuiller à sauce
cuchara gourmet
cucchiaio gourmet



■ 54.3035.6030
■ 54.3035.6040

Fischgabel
190 mm/7½ in.
fish fork
fourchette à poisson
tenedor pescado
forchetta pesce



■ 54.3036.6030
■ 54.3036.6040

Fischmesser
214 mm/8½ in.
fish knife
couteau à poisson
cuchillo pescado
coltello pesce



■ 54.3064.6030
■ 54.3064.6040

Kuchengabel
157 mm/6¼ in.
cake fork
fourchette à gâteau
tenedor lunch
forchetta per dolce



■ 54.3066.6039
■ 54.3066.6049

**Brot- /
Buttermesser****
170 mm/6¾ in.
bread/butter knife**
couteau de table**
cuchillo lunch**
coltello per dolce**



■ 54.3072.6030
■ 54.3072.6040

Limolöffel
220 mm/8¾ in.
iced tea spoon
cuiller à soda
cuchara refresco
cucchiaio bibita



■ 54.3078.6039
■ 54.3078.6049

Steakmesser**
242,5 mm/9½ in.
steak knife**
couteau à steak**
cuchillo steak**
coltello da bistecca**



■ 54.3089.6030
■ 54.3089.6040

Tassenlöffel
174 mm/7 in.
round bowl soup spoon
cuiller à bouillon
cuchara sopa
cucchiaio da brodo



VPE 12 Stk. / Unit 12 pcs.

■ perfekte Versilberung /
perfectly silverplated

■ Cromargan®, poliert /
stainless 18/10, polished

* Hohlheft mit Wellenschliff /
hollow-handled with serrated edge

** Klingenstahl mit Wellenschliff /
monobloc with serrated edge



■ **54 3000 6030**
 perfekt versilbert
 perfectly silverplated
 chromage parfait
 plateado perfecto
 perfetta placcatura in argento

■ **54 3000 6040**
 Cromargan®, poliert
 Cromargan®, polished
 Cromargan®, poli
 Cromargan®, pulido
 Cromargan®, lucido

Barock akzentuiert erlesene Menüfolgen mit seiner traditionellen Schönheit. Filigrane Ornamente und tropfenförmige Griffe unterstreichen die Eleganz festlicher Tafeln.

With its traditional beauty, Barock accentuates the fine-dining experience. Elegant embellishments and drop-shaped handles add to the sophistication of any festive table.

BAROCK
 3000





Extravagant.
Extravagant.

Außergewöhnlich.
Extraordinary.

Brilliant.
Brilliant.

JUWEL

■ 54.7301.6030
■ 54.7301.6040

Menuelöffel

213 mm/8³/₄ in.
table spoon
cuiller de table
cuchara mesa
cucchiaio tavola



■ 54.7302.6030
■ 54.7302.6040

Menuegabel

211 mm/8¹/₄ in.
table fork
fourchette de table
tenedor mesa
forchetta tavola



■ 54.7303.6037
■ 54.7303.6047

Menuemesser*

236 mm/9¹/₄ in.
table knife*
couteau de table*
cuchillo mesa*
coltello tavola cutinato*



■ 54.7303.6039
■ 54.7303.6049

Menuemesser**

239 mm/9¹/₂ in.
table knife**
couteau de table**
cuchillo mesa**
coltello tavola cutinato**



■ 54.7304.6030
■ 54.7304.6040

Vorspeisenlöffel

196 mm/7³/₄ in.
dessert spoon
cuiller à dessert
cuchara postre
cucchiaio frutta



■ 54.7305.6030
■ 54.7305.6040

Vorspeisengabel

194 mm/7³/₄ in.
dessert fork
fourchette à dessert
tenedor postre
forchetta frutta



■ 54.7306.6037
■ 54.7306.6047

**Vorspeisen-
messer***

212 mm/8¹/₄ in.
dessert knife*
couteau à dessert*
cuchillo postre*
coltello frutta*



■ 54.7306.6039
■ 54.7306.6049

**Vorspeisen-
messer****

220 mm/8³/₄ in.
dessert knife**
couteau à dessert**
cuchillo postre**
coltello frutta**



■ 54.7307.6030
■ 54.7307.6040

Kaffeelöffel

136 mm/5¹/₄ in.
tea/coffee spoon
cuiller à café
cuchara café
cucchiaio caffè/té



■ 54.7309.6030
■ 54.7309.6040

**Espresso- /
Mokkalöffel**

108 mm/4¹/₄ in.
demi-tasse spoon
cuiller à moca
cuchara moca
cucchiaio moca



■ 54.7310.6030
■ 54.7310.6040

**Vorspeisen- /
Dessertlöffel**

159 mm/6¹/₄ in.
coffee/tea spoon, large
cuiller à café/thé, grande
cuchara à café/té, grande
cucchiaio caffè/té, grande



■ 54.7311.6030
■ 54.7311.6040

Gourmetlöffel

193 mm/7¹/₂ in.
gourmet spoon
cuiller à sauce
cuchara gourmet
cucchiaio gourmet



■ 54.7335.6030
■ 54.7335.6040

Fischgabel

190 mm/7¹/₂ in.
fish fork
fourchette à poisson
tenedor pescado
forchetta pesce



■ 54.7336.6030
■ 54.7336.6040

Fischmesser

214 mm/8¹/₂ in.
fish knife
couteau à poisson
cuchillo pescado
coltello pesce



■ 54.7340.6030
■ 54.7340.6040

Austerngabel

149 mm/5³/₄ in.
oyster fork
fourchette à huîtres
tenedor ostras
forchetta per ostriche



■ 54.7364.6030
■ 54.7364.6040

Kuchengabel

158 mm/6¹/₄ in.
cake fork
fourchette à gâteau
tenedor lunch
forchetta per dolce



■ 54.7366.6039
■ 54.7366.6049

**Brot- /
Buttermesser****

170 mm/6³/₄ in.
bread/butter knife**
couteau de table**
cuchillo lunch
coltello per dolce**



■ 54.7372.6030
■ 54.7372.6040

Limolöffel

220 mm/8³/₄ in.
iced tea spoon
cuiller à soda
cuchara refresco
cucchiaio bibita



■ 54.7378.6039
■ 54.7378.6049

Steakmesser**

239 mm/9¹/₂ in.
steak knife**
couteau à steak**
cuchillo steak**
coltello da bistecca**



■ 54.7386.6039
■ 54.7386.6049

Obstmesser

170 mm/6³/₄ in.
fruit knife
couteau à fruits
cuchillo para fruta
coltello da frutta



■ 54.7389.6030
■ 54.7389.6040

Tassenlöffel

170 mm/6³/₄ in.
round bowl soup spoon
cuiller à bouillon
cuchara sopa
cucchiaio da brodo



VPE 12 Stk. / Unit 12 pcs.
■ perfekte Versilberung / perfectly silverplated
■ Cromargan®, poliert / stainless 18/10, polished
* Hohlheft mit Wellenschliff / hollow-handled with serrated edge
** Klingenstahl mit Wellenschliff / monobloc with serrated edge



NEU NEW

Obstmesser
Fruit knife

■ **54 7300 6030**
perfekt versilbert
perfectly silverplated
chromage parfait
plateado perfecto
perfetta placcatura in argento

■ **54 7300 6040**
Cromargan®, poliert
Cromargan®, polished
Cromargan®, poli
Cromargan®, pulido
Cromargan®, lucido

Juwel ist das funkelnde Highlight für jedes gehobene Ambiente. Die aufwendige Facettierung am Griffende erinnert an den Schliff eines Edelsteins und stammt aus der Feder der Designerin Jette Joop.

Juwel is a sparkling highlight that adds to any sophisticated setting. The complex beveling at the end of the handles is reminiscent of finely-cut gemstones and is a product of the imagination of designer Jette Joop.

JUWEL
7300





Pur.
Pure.

Minimalistisch.
Minimalist.

Ästhetisch.
Aesthetic.

NORDIC

■ 54.7201.6030

■ 54.7201.6040



Menuelöffel

230 mm/9 in.
table spoon
cuiller de table
cuchara mesa
cucchiaio tavola

■ 54.7235.6030

■ 54.7235.6040



Fischgabel

203 mm/8 in.
fish fork
fourchette à poisson
tenedor pescado
forchetta pesce

■ 54.7202.6030

■ 54.7202.6040



Menuegabel

228 mm/9 in.
table fork
fourchette de table
tenedor mesa
forchetta tavola

■ 54.7236.6030

■ 54.7236.6040



Fischmesser

226 mm/9 in.
fish knife
couteau à poisson
cuchillo pescado
coltello pesce

■ 54.7203.6039

■ 54.7203.6049



Menuemesser**

246 mm/9 3/4 in.
table knife**
couteau de table**
cuchillo mesa**
coltello tavola cutinato**

■ 54.7240.6030

■ 54.7240.6040



Austerngabel

149 mm/5 7/8 in.
oyster fork
fourchette à huîtres
tenedor ostras
forchetta per ostriche

■ 54.7204.6030

■ 54.7204.6040



Vorspeisenlöffel

212 mm/8 1/2 in.
dessert spoon
cuiller à dessert
cuchara postre
cucchiaio frutta

■ 54.7264.6030

■ 54.7264.6040



Kuchengabel

164 mm/6 1/2 in.
cake fork
fourchette à gâteau
tenedor lunch
forchetta per dolce

■ 54.7205.6030

■ 54.7205.6040



Vorspeisengabel

210 mm/8 1/4 in.
dessert fork
fourchette à dessert
tenedor postre
forchetta frutta

■ 54.7266.6039

■ 54.7266.6049



**Brot- /
Buttermesser****

170 mm/6 3/4 in.
bread/butter knife**
couteau de table**
cuchillo mesa**
coltello per dolce**

■ 54.7206.6039

■ 54.7206.6049



**Vorspeisen-
messer****

226 mm/9 in.
dessert knife**
cuiller à dessert**
cuchara postre**
cucchiaio frutta**

■ 54.7272.6030

■ 54.7272.6040



Limolöffel

220 mm/8 3/4 in.
iced tea spoon
cuiller à soda
cuchara refresco
cucchiaio bibita

■ 54.7207.6030

■ 54.7207.6040



Kaffeelöffel

140 mm/5 1/2 in.
tea/coffee spoon
cuiller à café
cuchara café
cucchiaio caffè/té

■ 54.7278.6039

■ 54.7278.6049



Steakmesser**

248 mm/9 3/4 in.
steak knife**
couteau à steak**
cuchillo steak**
coltello da bistecca**

■ 54.7209.6030

■ 54.7209.6040



**Espresso- /
Mokkalöffel**

110 mm/4 1/4 in.
demi-tasse spoon
cuiller à moca
cuchara moca
cucchiaio moca

■ 54.7286.6039

■ 54.7286.6049



Obstmesser

170 mm/6 3/4 in.
fruit knife
couteau à fruits
cuchillo para fruta
coltello da frutta

■ 54.7210.6030

■ 54.7210.6040



**Vorspeisen- /
Dessertlöffel**

163 mm/6 1/2 in.
coffee/tea spoon, large
cuiller à café/thé, grande
cuchara à café/té, grande
cucchiaio caffè/té, grande

■ 54.7289.6030

■ 54.7289.6040



Tassenlöffel

181 mm/7 1/4 in.
round bowl soup spoon
cuiller à bouillon
cuchara sopa
cucchiaio da brodo

■ 54.7211.6030

■ 54.7211.6040



Gourmetlöffel

203 mm/8 in.
gourmet spoon
cuiller à sauce
cuchara salsa
cucchiaio gourmet

VPE 12 Stk. / Unit 12 pcs.

■ perfekte Versilberung /
perfectly silverplated

■ Cromargan®, poliert /
stainless 18/10, polished

** Klingenstahl mit Wellenschliff /
monobloc with serrated edge

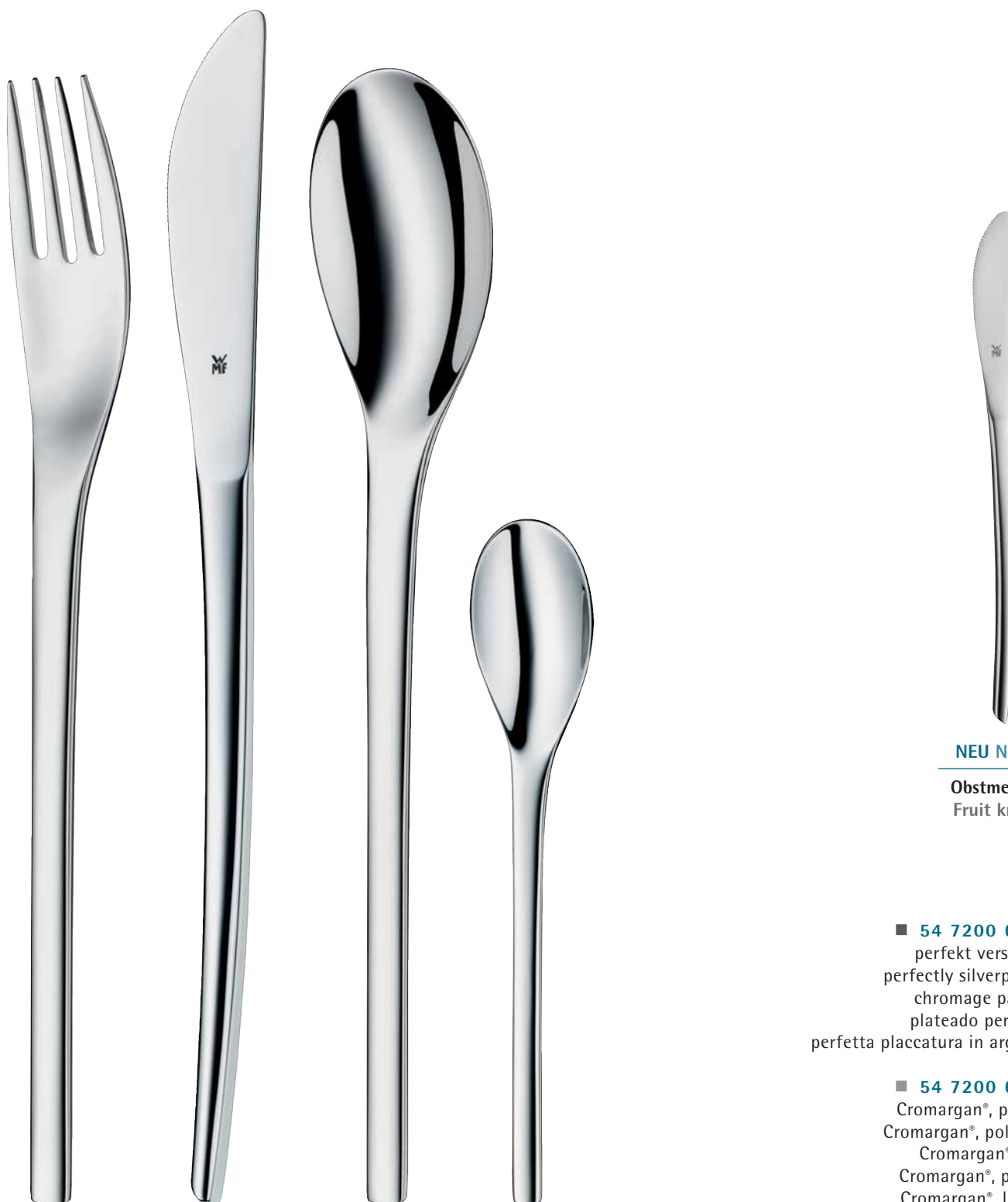

NEU NEW

Obstmesser
Fruit knife

■ **54 7200 6030**
perfekt versilbert
perfectly silverplated
chromage parfait
plateado perfecto
perfetta placcatura in argento

■ **54 7200 6040**
Cromargan®, poliert
Cromargan®, polished
Cromargan®, poli
Cromargan®, pulido
Cromargan®, lucido

Nordic besticht durch kühle Eleganz und eine außergewöhnliche Grifflänge. Umgeben von minimalistischem Interieur, fügt sich das klare Design stimmig ins Gesamtbild.

Nordic stands out thanks to its cool elegance and unusual handle length. In a minimalist interior setting, its clear design fits harmoniously into the overall look.

NORDIC
7200





Stark.
Powerful.

Herausragend.
Magnificent.

Schlank.
Streamlined.

TELOS

■ 54.1801.6040

Menuelöffel

212 mm/8³/₄ in.
table spoon
cuiller de table
cuchara mesa
cucchiaio tavola



■ 54.1864.6040

Kuchengabel

159 mm/6¹/₄ in.
cake fork
fourchette à gâteau
tenedor lunch
forchetta per dolce



■ 54.1802.6040

Menuegabel

211 mm/8³/₄ in.
table fork
fourchette de table
tenedor mesa
forchetta tavola



■ 54.1866.6049

**Brot- /
Buttermesser****

180 mm/7 in.
bread/butter knife**
couteau de table**
cuchillo lunch**
coltello per dolce**



■ 54.1803.6049

Menuemesser**

234 mm/9¹/₄ in.
table knife**
couteau de table**
cuchillo mesa**
coltello tavola cutinato**



■ 54.1889.6040

Tassenlöffel

170 mm/6³/₄ in.
round bowl soup spoon
cuiller à bouillon
cuchara sopa
cucchiaio da brodo



■ 54.1804.6040

Vorspeisenlöffel

190 mm/7¹/₂ in.
dessert spoon
cuiller à dessert
cuchara postre
cucchiaio frutta



■ 54.1805.6040

Vorspeisengabel

189 mm/7¹/₂ in.
dessert fork
fourchette à dessert
tenedor postre
forchetta frutta



■ 54.1806.6049

**Vorspeisen-
messer****

210 mm/8³/₄ in.
dessert knife**
couteau à dessert**
cuchillo postre**
coltello frutta**



■ 54.1807.6040

Kaffeelöffel

136 mm/5¹/₄ in.
tea/coffee spoon
cuiller à café
cuchara café
cucchiaio caffè/té



■ 54.1809.6040

**Espresso- /
Mokkalöffel**

108 mm/4¹/₄ in.
demi-tasse spoon
cuiller à mocca
cuchara moca
cucchiaio moca



■ 54.1810.6040

**Vorspeisen- /
Dessertlöffel**

158 mm/6¹/₄ in.
coffee/tea spoon, large
cuiller à café/thé, grande
cuchara à café/té, grande
cucchiaio caffè/té, grande



■ 54.1836.6040

Fischmesser

208 mm/8¹/₄ in.
fish knife
couteau à poisson
cuchillo pescado
coltello pesce



VPE 12 Stk. / Unit 12 pcs.

■ Cromargan®, poliert /
stainless 18/10, polished

** Klingenstahl mit Wellenschliff /
monobloc with serrated edge



■ **54 1800 6040**
 Cromargan®, poliert
 Cromargan®, polished
 Cromargan®, poli
 Cromargan®, pulido
 Cromargan®, lucido

Telos entspricht den Bedürfnissen international orientierter Gastronomiekonzepte auf ganzer Linie. Dank der eingängigen Form avanciert das Modell zum zeitlosen Klassiker für die gehobene Gastronomie.

Telos satisfies the needs of international catering concepts in every way. With its recognizable shape, this model is advancing into a timeless classic for sophisticated dining.

TELOS
 1800



Menu



Energisch.
Energetic.

Robust.
Robust.

Ausgewogen.
Balanced.

CASINO

■ 54.9001.6030

■ 54.9001.6040

**Menuelöffel**210 mm/8¹/₄ in.
table spoon
cuiller de table
cuchara mesa
cucchiaio tavola

■ 54.9002.6030

■ 54.9002.6040

**Menuegabel**208 mm/8¹/₄ in.
table fork
fourchette de table
tenedor mesa
forchetta tavola

■ 54.9003.6039

■ 54.9003.6049

**Menuemesser****234 mm/9¹/₄ in.
table knife**
couteau de table**
cuchillo mesa**
coltello tavola cutinato*

■ 54.9004.6030

■ 54.9004.6040

**Vorspeisenlöffel**190 mm/7¹/₂ in.
dessert spoon
cuiller à dessert
cuchara postre
cucchiaio frutta

■ 54.9005.6030

■ 54.9005.6040

**Vorspeisengabel**188 mm/7¹/₂ in.
dessert fork
fourchette à dessert
tenedor postre
forchetta frutta

■ 54.9006.6039

■ 54.9006.6049

**Vorspeisenmesser****212 mm/8¹/₄ in.
dessert knife**
couteau à dessert**
cuchillo postre**
coltello frutta**

■ 54.9007.6030

■ 54.9007.6040

**Kaffeelöffel**134 mm/5¹/₄ in.
tea/coffee spoon
cuiller à café
cuchara café
cucchiaio caffè/té

■ 54.9009.6030

■ 54.9009.6040

**Espresso- / Mokkalöffel**108 mm/4¹/₄ in.
demi-tasse spoon
cuiller à mocca
cuchara moca
cucchiaio moca

■ 54.9010.6030

■ 54.9010.6040

**Vorspeisen- / Dessertlöffel**159 mm/6¹/₄ in.
coffee/tea spoon, large
cuiller à café/thé, grande
cuchara à café/té, grande
cucchiaio caffè/té, grande

■ 54.9011.6030

■ 54.9011.6040

**Gourmetlöffel**190 mm/7¹/₂ in.
gourmet spoon
cuiller à sauce
cuchara gourmet
cucchiaio gourmet

■ 54.9035.6030

■ 54.9035.6040

**Fischgabel**179 mm/7 in.
fish fork
fourchette à poisson
tenedor pescado
forchetta pesce

■ 54.9036.6030

■ 54.9036.6040

**Fischmesser**201 mm/8 in.
fish knife
couteau à poisson
cuchillo pescado
coltello pesce

■ 54.9040.6030

■ 54.9040.6040

**Austerngabel**149 mm/5⁷/₈ in.
oyster fork
fourchette à huîtres
tenedor ostras
forchetta per ostriche

■ 54.9064.6030

■ 54.9064.6040

**Kuchengabel**158 mm/6¹/₄ in.
cake fork
fourchette à gâteau
tenedor lunch
forchetta per dolce

■ 54.9066.6039

■ 54.9066.6049

**Brot- / Buttermesser****170 mm/6³/₄ in.
bread/butter knife**
couteau de table**
cuchillo lunch**
coltello per dolce**

■ 54.9072.6030

■ 54.9072.6040

**Limolöffel**220 mm/8³/₄ in.
iced tea spoon
cuiller à soda
cuchara refresco
cucchiaio bibita

■ 54.9078.6039

■ 54.9078.6049

**Steakmesser****234 mm/9¹/₄ in.
steak knife**
couteau à steak**
cuchillo steak**
coltello da bistecca**

■ 54.9089.6030

■ 54.9089.6040

**Tassenlöffel**168 mm/6¹/₂ in.
round bowl soup spoon
cuiller à bouillon
cuchara sopa
cucchiaio da brodo

■ 54.9090.6039

■ 54.9090.6049

**Pizzamesser**234 mm/9¹/₄ in.
pizza knife
couteau à pizza
cuchillo pizza
coltello da pizza

■ 54.1603.6037

■ 54.1603.6047

**Menuemesser***236 mm/9¹/₄ in.
table knife*
couteau de table*
cuchillo mesa*
coltello tavola cutinato*

■ 54.1603.6039

■ 54.1603.6049

**Menuemesser*****236 mm/9¹/₄ in.
table knife***
couteau de table***
cuchillo mesa***
coltello tavola cutinato***

■ 54.1606.6037

■ 54.1606.6047

**Vorspeisenmesser***217 mm/8¹/₂ in.
dessert knife*
couteau à dessert*
cuchillo postre*
coltello frutta*

■ 54.1606.6039

■ 54.1606.6049

**Vorspeisenmesser*****217 mm/8¹/₂ in.
dessert knife***
couteau à dessert***
cuchillo postre***
coltello frutta***

VPE 12 Stk. / Unit 12 pcs.

- perfekte Versilberung / perfectly silverplated
- Cromargan®, poliert / stainless 18/10, polished

* Hohlheft mit Wellenschliff, steht auch auf Klinge / hollow-handle with serrated edge, standing on blade optional

** Klingenstahl mit Wellenschliff / monobloc with serrated edge

*** Klingenstahl mit Wellenschliff, steht auch auf Klinge / monobloc with serrated edge, standing on blade optional



NEU NEW

Pizzamesser
Pizza knife

■ **54 9000 6030**
perfekt versilbert
perfectly silverplated
chromage parfait
plateado perfecto
perfetta placcatura in argento

■ **54 9000 6040**
Cromargan®, poliert
Cromargan®, polished
Cromargan®, poli
Cromargan®, pulido
Cromargan®, lucido

Casino wohnt ein klarer und zugleich eleganter Charakter inne. Die Kollektion wirkt wie aus einem Guss und ist prädestiniert als Begleiter stilsicherer Genusswelten.

Casino has a simple, yet elegant character. The collection forms a seamless whole and perfectly complements any stylish culinary environment.

CASINO
9000





Stimmig.
Harmonious.

Prägnant.
Distinctive.

Dezent.
Discreet.

SOLID

■ 10.7901.6060
■ 12.7901.6040

Menuelöffel

212 mm/8³/₄ in.
table spoon
cuiller de table
cuchara mesa
cucchiaio tavola



■ 10.7902.6060
■ 12.7902.6040

Menuegabel

210 mm/8¹/₄ in.
table fork
fourchette de table
tenedor mesa
forchetta tavola



■ 10.7903.6067
■ 12.7903.6047

Menuemesser*

246 mm/9³/₄ in.
table knife*
couteau de table*
cuchillo mesa*
coltello tavola cutinato*



■ 10.7903.6069
■ 12.7903.6049

Menuemesser**

239 mm/9¹/₂ in.
table knife**
couteau de table**
cuchillo mesa**
coltello tavola cutinato**



■ 10.7904.6060
■ 12.7904.6040

Vorspeisenlöffel

190 mm/7¹/₂ in.
dessert spoon
cuiller à dessert
cuchara postre
cucchiaio frutta



■ 10.7905.6060
■ 12.7905.6040

Vorspeisengabel

188 mm/7¹/₂ in.
dessert fork
fourchette à dessert
tenedor postre
forchetta frutta



■ 10.7906.6067
■ 12.7906.6047

**Vorspeisen-
messer***

220 mm/8³/₄ in.
dessert knife*
couteau à dessert*
cuchillo postre*
coltello frutta*



■ 10.7906.6069
■ 12.7906.6049

**Vorspeisen-
messer****

214 mm/8¹/₂ in.
dessert knife**
couteau à dessert**
cuchillo postre**
coltello frutta**



■ 10.7907.6060
■ 12.7907.6040

Kaffeelöffel

136 mm/5¹/₄ in.
tea/coffee spoon
cuiller à café
cuchara café
cucchiaio caffè/té



■ 10.7909.6060
■ 12.7909.6040

**Espresso- /
Mokkalöffel**

108 mm/4¹/₄ in.
demi-tasse spoon
cuiller à mocca
cuchara moca
cucchiaio moca



■ 10.7910.6060
■ 12.7910.6040

**Vorspeisen- /
Dessertlöffel**

159 mm/6¹/₄ in.
coffee/tea spoon, large
cuiller à café/thé, grande
cuchara à café/té, grande
cucchiaio caffè/té, grande



■ 10.7911.6060
■ 12.7911.6040

Gourmetlöffel

190 mm/7¹/₂ in.
gourmet spoon
cuiller à sauce
cuchara gourmet
cucchiaio gourmet



■ 10.7935.6062
■ 12.7935.6042

Fischgabel

188 mm/7¹/₂ in.
fish fork
fourchette à poisson
tenedor pescado
forchetta pesce



■ 10.7935.6063
■ 12.7935.6043

Fischmesser

209 mm/8¹/₄ in.
fish knife
couteau à poisson
cuchillo pescado
coltello pesce



■ 10.7940.6060
■ 12.7940.6040

Austerngabel

149 mm/5³/₄ in.
oyster fork
fourchette à huîtres
tenedor ostras
forchetta per ostriche



■ 10.7964.6060
■ 12.7964.6040

Kuchengabel

160 mm/6¹/₄ in.
cake fork
fourchette à gâteau
tenedor lunch
forchetta per dolce



■ 10.7966.6069
■ 12.7966.6049

**Brot- /
Buttermesser****

170 mm/6²/₄ in.
bread/butter knife**
couteau de table**
cuchillo lunch**
coltello per dolce**



■ 10.7972.6060
■ 12.7972.6040

Limolöffel

220 mm/8³/₄ in.
iced tea spoon
cuiller à soda
cuchara refresco
cucchiaio bibita



■ 10.7978.6069
■ 12.7978.6049

Steakmesser**

235 mm/9¹/₄ in.
steak knife**
couteau à steak**
cuchillo steak**
coltello da bistecca**



■ 10.7989.6060
■ 12.7989.6040

Tassenlöffel

170 mm/6²/₄ in.
round bowl soup spoon
cuiller à bouillon
cuchara sopa
cucchiaio da brodo



VPE 12 Stk. / Unit 12 pcs.

■ perfekte Versilberung /
perfectly silverplated

■ Cromargan®, poliert /
stainless 18/10, polished

* Hohlheft mit Wellenschliff /
hollow-handled with serrated edge

** Klingenstahl mit Wellenschliff /
monobloc with serrated edge



■ **10 7900 6060**
 perfekt versilbert
 perfectly silverplated
 chromage parfait
 plateado perfecto
 perfetta placcatura in argento

■ **12 7900 6040**
 Cromargan®, poliert
 Cromargan®, polished
 Cromargan®, poli
 Cromargan®, pulido
 Cromargan®, lucido

Solid betont mit seiner gediegenen und dennoch nicht alltäglichen Optik verschiedene Inszenierungen zünftiger Gastronomiekonzepte. Mit kräftigen Formen und langen Zinken ist das Modell bestens ausbalanciert.

Solid has a dignified, yet extraordinary appearance and can complement a range of different looks for authentic catering concepts. With its powerful forms and long tines, this collection is perfectly balanced.

SOLID
 7900





Stylisch.
Stylish.

Endlos.
Infinite.

Schlicht.
Simple.

BASE

■ 12.2301.6040

Menuelöffel

199 mm/7⁷/₈ in.
table spoon
cuiller de table
cuchara mesa
cucchiaio tavola



■ 12.2366.6049

**Brot- /
Buttermesser****

177 mm/7 in.
bread/butter knife**
couteau de table**
cuchillo lunch**
coltello per dolce**



■ 12.2302.6040

Menuegabel

197 mm/7⁷/₈ in.
table fork
fourchette de table
tenedor mesa
forchetta tavola



■ 12.2389.6040

Tassenlöffel

166 mm/6¹/₂ in.
round bowl soup spoon
cuiller à bouillon
cuchara sopa
cucchiaio da brodo



■ 12.2303.6049

Menuemesser**

226 mm/9 in.
table knife**
couteau de table**
cuchillo mesa**
coltello tavola cutinato**



■ 12.2304.6040

Vorspeisenlöffel

187 mm/7¹/₄ in.
dessert spoon
cuiller à dessert
cuchara postre
cucchiaio frutta



■ 12.2305.6040

Vorspeisengabel

185 mm/7¹/₄ in.
dessert fork
fourchette à dessert
tenedor postre
forchetta frutta



■ 12.2306.6049

**Vorspeisen-
messer****

213 mm/8¹/₂ in.
dessert knife**
couteau à dessert**
cuchillo postre**
coltello frutta**



■ 12.2307.6040

Kaffeelöffel

132 mm/5¹/₄ in.
tea/coffee spoon
cuiller à café
cuchara café
cucchiaio caffè/té



■ 12.2309.6040

**Espresso- /
Mokkalöffel**

108 mm/4¹/₄ in.
demi-tasse spoon
cuiller à mocca
cuchara moca
cucchiaio moca



■ 12.2310.6040

**Vorspeisen- /
Dessertlöffel**

156 mm/6¹/₄ in.
coffee/tea spoon, large
cuiller à café/thé, grande
cuchara à café/té, grande
cucchiaio caffè/té, grande



■ 12.2364.6040

Kuchengabel

157 mm/6¹/₄ in.
cake fork
fourchette à gâteau
tenedor lunch
forchetta per dolce



VPE 12 Stk. / Unit 12 pcs.

■ Cromargan®, poliert /
stainless 18/10, polished

** Klingenstahl mit Wellenschliff /
monobloc with serrated edge



■ 12 2300 6040
 Cromargan®, poliert
 Cromargan®, polished
 Cromargan®, poli
 Cromargan®, pulido
 Cromargan®, lucido

Base ist für die Ewigkeit gemacht. Mit seiner schlichten Formgebung flankiert das Besteck die unterschiedlichsten Formen und Farben an Porzellan sowie Accessoires.

Base is never going to be out of fashion. With its simple forms, this cutlery complements porcelain and accessories of all shapes and colors.

BASE
 2300





Direkt.
Straight.

Markant.
Striking.

Modern.
Modern.

UNIC

■ 10.5301.6060
■ 12.5301.6040

Menuelöffel
215 mm/8½ in.
table spoon
cuiller de table
cuchara mesa
cucchiaio tavola



■ 10.5302.6060
■ 12.5302.6040

Menuegabel
214 mm/8½ in.
table fork
fourchette de table
tenedor mesa
forchetta tavola



■ 10.5303.6061
■ 12.5303.6041

Menuemesser***
237 mm/9½ in.
table knife***
couteau de table***
cuchillo mesa***
coltello tavola***



■ 10.5303.6067
■ 12.5303.6047

Menuemesser*
233 mm/9¼ in.
table knife*
couteau de table*
cuchillo mesa*
coltello tavola cutinato*



■ 10.5303.6069
■ 12.5303.6049

Menuemesser**
236 mm/9¼ in.
table knife**
couteau de table**
cuchillo mesa**
coltello tavola**



■ 10.5304.6060
■ 12.5304.6040

Vorspeisenlöffel
196 mm/7¾ in.
dessert spoon
cuiller à dessert
cuchara postre
cucchiaio frutta



■ 10.5305.6060
■ 12.5305.6040

Vorspeisengabel
195 mm/7¾ in.
dessert fork
fourchette à dessert
tenedor postre
forchetta frutta



■ 10.5306.6061
■ 12.5306.6041

Vorspeisenmesser****
216 mm/8½ in.
dessert knife***
couteau à dessert***
cuchillo postre***
coltello frutta***



■ 10.5306.6067
■ 12.5306.6047

Vorspeisenmesser*
212 mm/8½ in.
dessert knife*
couteau à dessert*
cuchillo postre*
coltello frutta*



■ 10.5306.6069
■ 12.5306.6049

Vorspeisenmesser**
215 mm/8½ in.
dessert knife**
couteau à dessert**
cuchillo postre**
coltello frutta**



■ 10.5307.6060
■ 12.5307.6040

Kaffeelöffel
136 mm/5¼ in.
tea/coffee spoon
cuiller à café
cuchara café
cucchiaio caffè/té



■ 10.5309.6060
■ 12.5309.6040

Espresso- / Mokkalöffel
108 mm/4¼ in.
demi-tasse spoon
cuiller à moca
cuchara moca
cucchiaio moca



■ 10.5310.6060
■ 12.5310.6040

Vorspeisen- / Dessertlöffel
156 mm/6¼ in.
coffee/tea spoon, large
cuiller à café/thé, grande
cuchara à café/té, grande
cucchiaio caffè/té, grande



■ 10.5311.6060
■ 12.5311.6040

Gourmetlöffel
196 mm/7¾ in.
gourmet spoon
cuiller à sauce
cuchara gourmet
cucchiaio gourmet



■ 10.5335.6061
■ 12.5335.6041

Fischmesser****
216 mm/8½ in.
fish knife****
couteau à poisson****
cuchillo pescado****
coltello pesce****



■ 10.5335.6062
■ 12.5335.6042

Fischgabel
190 mm/7½ in.
fish fork
fourchette à poisson
tenedor pescado
forchetta pesce



■ 10.5335.6063
■ 12.5335.6043

Fischmesser
215 mm/8½ in.
fish knife
couteau à poisson
cuchillo pescado
coltello pesce



■ 10.5340.6060
■ 12.5340.6040

Austerngabel
149 mm/5¾ in.
oyster fork
fourchette à huîtres
tenedor ostras
forchetta per ostriche



■ 10.5364.6060
■ 12.5364.6040

Kuchengabel
157 mm/6¼ in.
cake fork
fourchette à gâteau
tenedor lunch
forchetta per dolce



■ 10.5366.6061
■ 12.5366.6041

Brot- / Buttermesser***
170 mm/6¾ in.
bread/butter knife***
couteau de table***
cuchillo lunch***
coltello per dolce***



■ 10.5366.6069
■ 12.5366.6049

Brot- / Buttermesser**
170 mm/6¾ in.
bread/butter knife**
couteau de table**
cuchillo mesa**
coltello per dolce**



■ 10.5372.6060
■ 12.5372.6040

Limolöffel
220 mm/8½ in.
iced tea spoon
cuiller à soda
cuchara refresco
cucchiaio bibita



■ 10.5378.6069
■ 12.5378.6049

Steakmesser**
239 mm/9½ in.
steak knife**
couteau à steak**
cuchillo steak**
coltello da bistecca**



■ 10.5389.6060
■ 12.5389.6040

Tassenlöffel
174 mm/6¾ in.
round bowl soup spoon
cuiller à bouillon
cuchara sopa
cucchiaio da brodo



VPE 12 Stk. / Unit 12 pcs.

- perfekte Versilberung / perfectly silverplated
- Cromargan®, poliert / stainless 18/10, polished

* Hohlheft mit Wellenschliff / hollow-handled with serrated edge

** Klingenstahl mit Wellenschliff / monobloc with serrated edge

*** Klingenstahl mit Wellenschliff, steht auch auf Klinge / monobloc with serrated edge, standing on blade optional

**** Klingenstahl, steht auf Klinge / monobloc, standing on blade optional



■ **10 5300 6060**
 perfekt versilbert
 perfectly silverplated
 chromage parfait
 plateado perfecto
 perfetta placcatura in argento

■ **12 5300 6040**
 Cromargan®, poliert
 Cromargan®, polished
 Cromargan®, poli
 Cromargan®, pulido
 Cromargan®, lucido

Unic macht einen klassischen Eindruck – und das trotz der designorientierten Silhouette. Die streng parallel verlaufende Linienführung passt zu jeglicher Art von modernen Tafeln.

Unic makes a classic impression, despite its design-oriented silhouette. Its strong parallel lines fit perfectly with any modern table design.

UNIC
5300



laube

Mail
n Dill



Harmonisch.
Harmonious.

Klassisch.
Classic.

Vielseitig.
Versatile.

GASTRO

■ 12.0801.6040

Menuelöffel

195 mm/7³/₄ in.



table spoon
cuiller de table
cuchara mesa
cucchiaio tavola

■ 12.0810.6040

**Vorspeisen- /
Dessertlöffel**

156 mm/6¹/₄ in.



coffee/tea spoon, large
cuiller à café/thé, grande
cuchara lunch
cucchiaio caffè/té grande

■ 12.0802.6040

Menuegabel

193 mm/7¹/₂ in.



table fork
fourchette de table
tenedor mesa
forchetta tavola

■ 12.0835.6042

Fischgabel

178 mm/7 in.



fish fork
fourchette à poisson
tenedor pescado
forchetta pesce

■ 12.0803.6047

Menuemesser*

209 mm/8¹/₂ in.



table knife*
couteau de table*
cuchillo mesa*
coltello tavola cutinato*

■ 12.0835.6043

Fischmesser

205 mm/8 in.



fish knife
couteau à poisson
cuchillo pescado
coltello pesce

■ 12.0803.6049

Menuemesser**

209 mm/8¹/₂ in.



table knife**
couteau de table**
cuchillo mesa**
coltello tavola cutinato**

■ 12.0864.6040

Kuchengabel

157 mm/6¹/₄ in.



cake fork
fourchette à gâteau
tenedor lunch
forchetta per dolce

■ 12.0804.6040

Vorspeisenlöffel

182 mm/7¹/₂ in.



dessert spoon
cuiller à dessert
cuchara postre
cucchiaio frutta

■ 12.0866.6049

**Brot- /
Buttermesser****

168 mm/6¹/₂ in.



bread/butter knife**
couteau de table**
cuchillo lunch**
coltello per dolce**

■ 12.0805.6040

Vorspeisengabel

180 mm/7 in.



dessert fork
fourchette à dessert
tenedor postre
forchetta frutta

■ 12.0872.6040

Limolöffel

220 mm/8³/₄ in.



iced tea spoon
cuiller à soda
cuchara refresco
cucchiaio bibita

■ 12.0806.6047

**Vorspeisen-
messer***

195 mm/7³/₄ in.



dessert knife*
couteau à dessert*
cuchillo postre*
coltello frutta*

■ 12.0878.6047

Steakmesser*

232 mm/9¹/₄ in.



steak knife*
couteau à steak*
cuchillo steak*
coltello da bistecca*

■ 12.0806.6049

**Vorspeisen-
messer****

195 mm/7³/₄ in.



dessert knife**
couteau à dessert**
cuchillo postre**
coltello frutta**

■ 12.0878.6049

Steakmesser**

232 mm/9¹/₄ in.



steak knife**
couteau à steak**
cuchillo steak**
coltello da bistecca**

■ 12.0807.6040

Kaffeelöffel

132 mm/5¹/₄ in.



tea/coffee spoon
cuiller à café
cuchara café
cucchiaio caffè/té

■ 12.0889.6040

Tassenlöffel

168 mm/6¹/₂ in.



round bowl soup spoon
cuiller à bouillon
cuchara sopa
cucchiaio da brodo

■ 12.0809.6040

**Espresso- /
Mokkalöffel**

108 mm/4¹/₄ in.



demi-tasse spoon
cuiller à moca
cuchara moca
cucchiaio moca

VPE 12 Stk. / Unit 12 pcs.

■ Cromargan®, poliert /
stainless 18/10, polished

* Hohlheft mit Wellenschliff /
hollow-handled with serrated edge

** Klingenstahl mit Wellenschliff /
monobloc with serrated edge



■ 12 0800 6040
 Cromargan®, poliert
 Cromargan®, polished
 Cromargan®, poli
 Cromargan®, pulido
 Cromargan®, lucido

Gastro ist dank seiner dezenten und gleichzeitig eleganten Silhouette wie geschaffen für originelle Gastro-Konzepte. Drapiert auf kariertem Tischwäsche oder einfachen Holztischen entfaltet sich der typische Flair.

With its understated, yet elegant silhouette, Gastro is the ideal choice for original catering concepts. Bring out the best in this cutlery by laying it out on checked table linens or simple wooden tables.

GASTRO
 0800





Geschmeidig.
Smooth.

Vertraut.
Familiar.

Etabliert.
Established.

SIGNUM

■ 10.1901.6060
■ 12.1901.6040

Menuelöffel

212 mm/8¹/₂ in.
table spoon
cuiller de table
cuchara mesa
cucchiaio tavola



■ 10.1902.6060
■ 12.1902.6040

Menuegabel

210 mm/8¹/₂ in.
table fork
fourchette de table
tenedor mesa
forchetta tavola



■ 10.1903.6067
■ 12.1903.6047

Menuemesser*

239 mm/9¹/₂ in.
table knife*
couteau de table*
cuchillo mesa*
coltello tavola cutinato*



■ 10.1903.6069
■ 12.1903.6049

Menuemesser**

238 mm/9¹/₂ in.
table knife**
couteau de table**
cuchillo mesa**
coltello tavola cutinato**



■ 10.1904.6060
■ 12.1904.6040

Vorspeisenlöffel

190 mm/7¹/₂ in.
dessert spoon
cuiller à dessert
cuchara postre
cucchiaio frutta



■ 10.1905.6060
■ 12.1905.6040

Vorspeisengabel

188 mm/7¹/₂ in.
dessert fork
fourchette à dessert
tenedor postre
forchetta frutta



■ 10.1906.6067
■ 12.1906.6047

**Vorspeisen-
messer***

214 mm/8¹/₂ in.
dessert knife*
couteau à dessert*
cuchillo postre*
coltello frutta*



■ 10.1906.6069
■ 12.1906.6049

**Vorspeisen-
messer****

213 mm/8¹/₂ in.
dessert knife**
couteau à dessert**
cuchillo postre**
coltello frutta**



■ 10.1907.6060
■ 12.1907.6040

Kaffeelöffel

136 mm/5¹/₂ in.
tea/coffee spoon
cuiller à café
cuchara café
cucchiaio caffè/té



■ 10.1909.6060
■ 12.1909.6040

**Espresso- /
Mokkalöffel**

108 mm/4¹/₂ in.
demi-tasse spoon
cuiller à mocca
cuchara moca
cucchiaio moca



■ 10.1910.6060
■ 12.1910.6040

**Vorspeisen- /
Dessertlöffel**

156 mm/6¹/₄ in.
coffee/tea spoon, large
cuiller à café/thé grande
cuchara à café/té, grande
cucchiaio caffè/té, grande



■ 10.1911.6060
■ 12.1911.6040

Gourmetlöffel

190 mm/7¹/₂ in.
gourmet spoon
cuiller à sauce
cuchara gourmet
cucchiaio gourmet



■ 10.1916.6060
■ 12.1916.6040

Gemüselöffel

237 mm/9¹/₂ in.
vegetable serving spoon
cuiller à légumes
cucharón legumbres
cucchiaione servire



■ 10.1935.6062
■ 12.1935.6042

Fischgabel

184 mm/7¹/₄ in.
fish fork
fourchette à poisson
tenedor pescado
forchetta pesce



■ 10.1935.6063
■ 12.1935.6043

Fischmesser

206 mm/8 in.
fish knife
couteau à poisson
cuchillo pescado
coltello pesce



■ 10.1940.6060
■ 12.1940.6040

Austergabel

149 mm/5³/₄ in.
oyster fork
fourchette à huîtres
tenedor ostras
forchetta per ostriche



■ 10.1964.6060
■ 12.1964.6040

Kuchengabel

157 mm/6¹/₄ in.
cake fork
fourchette à gâteau
tenedor lunch
forchetta per dolce



■ 10.1966.6069
■ 12.1966.6049

**Brot- /
Buttermesser****

170 mm/6³/₄ in.
bread/butter knife**
couteau de table**
cuchillo mesa**
coltello per dolce**



■ 10.1972.6060
■ 12.1972.6040

Limolöffel

220 mm/8³/₄ in.
iced tea spoon
cuiller à soda
cuchara refresco
cucchiaio bibita



■ 10.1978.6069
■ 12.1978.6049

Steakmesser**

239 mm/9¹/₂ in.
steak knife**
couteau à steak**
cuchillo steak**
coltello da bistecca**



■ 10.1986.6069
■ 12.1986.6049

Obstmesser

170 mm/6³/₄ in.
fruit knife
couteau à fruits
cuchillo para fruta
coltello da frutta



■ 10.1989.6060
■ 12.1989.6040

Tassenlöffel

170 mm/6³/₄ in.
round bowl soup spoon
cuiller à bouillon
cuchara sopa
cucchiaio da brodo



■ 10.1990.6069
■ 12.1990.6049

Pizzamesser

239 mm/9¹/₂ in.
pizza knife
couteau à pizza
cuchillo pizza
coltello da pizza



VPE 12 Stk. / Unit 12 pcs.

- perfekte Versilberung / perfectly silverplated
- Cromargan®, poliert / stainless 18/10, polished

* Hohlheft mit Wellenschliff / hollow-handled with serrated edge

** Klingenstahl mit Wellenschliff / monobloc with serrated edge



NEU NEW

Obstmesser
Fruit knife

Pizzamesser
Pizza knife

■ **10 1900 6060**
perfekt versilbert
perfectly silverplated
chromage parfait
plateado perfecto
perfetta placcatura in argento

■ **12 1900 6040**
Cromargan®, poliert
Cromargan®, polished
Cromargan®, poli
Cromargan®, pulido
Cromargan®, lucido

Signum vereint die traditionelle Rundstilform mit einer klaren Linienführung – und sorgt für ein modernes und zugleich vertrautes Tischambiente in ganz unterschiedlichen Interieur-Stilen.

Signum combines the traditional rounded handle with clear lines, helping to create a modern, yet familiar table ambience in all kinds of interiors.

SIGNUM
1900



Bon Appétit



Fein.
Delicate.

Schwungvoll.
Curvy.

Dekorativ.
Decorative.

CONTOUR

■ 10.0201.6060
 ■ 12.0201.6040
Menuelöffel
 200 mm/8 in.
 table spoon
 cuiller de table
 cuchara mesa
 cucchiaio tavola



■ 10.0202.6060
 ■ 12.0202.6040
Menuegabel
 203 mm/8 in.
 table fork
 fourchette de table
 tenedor mesa
 forchetta tavola



■ 10.0203.6067
 ■ 12.0203.6047
Menuemesser*
 230 mm/9 in.
 table knife*
 couteau de table*
 cuchillo mesa*
 coltello tavola cutinato*



■ 10.0203.6069
 ■ 12.0203.6049
Menuemesser**
 235 mm/9 1/4 in.
 table knife**
 couteau de table**
 cuchillo mesa**
 coltello tavola**



■ 10.0204.6060
 ■ 12.0204.6040
Vorspeisenlöffel
 182 mm/7 1/4 in.
 dessert spoon
 cuiller à dessert
 cuchara postre
 cucchiaio frutta



■ 10.0205.6060
 ■ 12.0205.6040
Vorspeisengabel
 185 mm/7 1/4 in.
 dessert fork
 fourchette à dessert
 tenedor postre
 forchetta frutta



■ 10.0206.6067
 ■ 12.0206.6047
**Vorspeisen-
 messer***
 211 mm/8 1/4 in.
 dessert knife*
 couteau à dessert*
 cuchillo postre*
 coltello frutta*



■ 10.0206.6069
 ■ 12.0206.6049
**Vorspeisen-
 messer****
 211 mm/8 1/4 in.
 dessert knife**
 couteau à dessert**
 cuchillo postre**
 coltello frutta**



■ 10.0207.6060
 ■ 12.0207.6040
Kaffeelöffel
 132 mm/5 1/4 in.
 tea/coffee spoon
 cuiller à café
 cuchara café
 cucchiaio caffè/té



■ 10.0209.6060
 ■ 12.0209.6040
**Espresso- /
 Mokkalöffel**
 108 mm/4 1/4 in.
 demi-tasse spoon
 cuiller à mocca
 cuchara moca
 cucchiaio moca



■ 10.0210.6060
 ■ 12.0210.6040
**Vorspeisen- /
 Dessertlöffel**
 156 mm/6 1/4 in.
 coffee/tea spoon, large
 cuiller à café/thé, grande
 cuchara à café/té, grande
 cucchiaio caffè/té, grande



■ 10.0211.6060
 ■ 12.0211.6040
Gourmetlöffel
 190 mm/7 1/2 in.
 gourmet spoon
 cuiller à sauce
 cuchara gourmet
 cucchiaio gourmet



■ 10.0235.6062
 ■ 12.0235.6042
Fischgabel
 174 mm/6 7/8 in.
 fish fork
 fourchette à poisson
 tenedor pescado
 forchetta pesce



■ 10.0235.6063
 ■ 12.0235.6043
Fischmesser
 204 mm/8 in.
 fish knife
 couteau à poisson
 cuchillo pescado
 coltello pesce



■ 10.0240.6060
 ■ 12.0240.6040
Austerngabel
 136 mm/5 1/4 in.
 oyster fork
 fourchette à huîtres
 tenedor ostras
 forchetta per ostriche



■ 10.0264.6060
 ■ 12.0264.6040
Kuchengabel
 152 mm/6 in.
 cake fork
 fourchette à gâteau
 tenedor lunch
 forchetta per dolce



■ 10.0266.6069
 ■ 12.0266.6049
**Brot- /
 Buttermesser****
 170 mm/6 7/8 in.
 bread/butter knife**
 couteau de table**
 cuchillo lunch**
 coltello per dolce**



■ 10.0272.6060
 ■ 12.0272.6040
Limolöffel
 220 mm/8 3/4 in.
 iced tea spoon
 cuiller à soda
 cuchara refresco
 cucchiaio bibita



■ 12.0278.6049
Steakmesser**
 225 mm/8 7/8 in.
 steak knife**
 couteau à steak**
 cuchillo steak**
 coltello da bistecca**



■ 10.0289.6060
 ■ 12.0289.6040
Tassenlöffel
 169 mm/6 7/8 in.
 round bowl soup spoon
 cuiller à bouillon
 cuchara sopa
 cucchiaio da brodo



VPE 12 Stk. / Unit 12 pcs.

- perfekte Versilberung / perfectly silverplated
- Cromargan®, poliert / stainless 18/10, polished

* Hohlheft mit Wellenschliff / hollow-handled with serrated edge

** Klingenstahl mit Wellenschliff / monobloc with serrated edge



■ **10 0200 6060**
 perfekt versilbert
 perfectly silverplated
 chromage parfait
 plateado perfecto
 perfetta placcatura in argento

■ **12 0200 6040**
 Cromargan®, poliert
 Cromargan®, polished
 Cromargan®, poli
 Cromargan®, pulido
 Cromargan®, lucido

Contour greift mit feinen Prägungen und tropfenförmigen Griffen traditionelle Besteckmuster auf moderne Weise auf. Die schwungvolle Linienführung fügt sich harmonisch in eine lockere Atmosphäre ein.

With its fine stamping and drop-shaped handles, Contour is a modern take on traditional cutlery designs. Its flowing lines perfectly suit a more relaxed atmosphere.

CONTOUR
 0200





Wandelbar.
Versatile.

Zeitlos.
Timeless.

Geradlinig.
Straightforward.

BISTRO

■ 01.0401.6060 **Menuelöffel**

■ 11.0401.6040
203 mm/8 in.
table spoon
cuiller de table
cuchara mesa
cucchiaio tavola



■ 01.0402.6060 **Menuegabel**

■ 11.0402.6040
201 mm/8 in.
table fork
fourchette de table
tenedor mesa
forchetta tavola



■ 01.0403.6067 **Menuemesser***

■ 11.0403.6047
230 mm/9 in.
table knife*
couteau de table*
cuchillo mesa*
coltello tavola cutinato*



■ 01.0403.6069 **Menuemesser****

■ 11.0403.6049
227 mm/9 in.
table knife**
couteau de table**
cuchillo mesa**
coltello tavola cutinato**



■ 01.0404.6060 **Vorspeisenlöffel**

■ 11.0404.6040
183 mm/7 1/4 in.
dessert spoon
cuiller à dessert
cuchara postre
cucchiaio frutta



■ 01.0405.6060 **Vorspeisengabel**

■ 11.0405.6040
181 mm/7 in.
dessert fork
fourchette à dessert
tenedor postre
forchetta frutta



■ 01.0406.6067 **Vorspeisen-**

■ 11.0406.6047
209 mm/8 1/4 in.
dessert knife*
couteau à dessert*
cuchillo postre*
coltello frutta*



■ 01.0406.6069 **Vorspeisen-**

■ 11.0406.6049
205 mm/8 in.
dessert knife**
couteau à dessert**
cuchillo postre**
coltello frutta**



■ 01.0407.6060 **Kaffeelöffel**

■ 11.0407.6040
132 mm/5 1/4 in.
tea/coffee spoon
cuiller à café
cuchara café
cucchiaio caffè/té



■ 01.0409.6060 **Espresso- /**

■ 11.0409.6040
108 mm/4 1/4 in.
demi-tasse spoon
cuiller à mocca
cuchara moca
cucchiaio moca



■ 01.0410.6060 **Vorspeisen- /**

■ 11.0410.6040
156 mm/6 1/4 in.
coffee/tea spoon, large
cuiller à café/thé, grande
cuchara à café/té, grande
cucchiaio caffè/té grande



■ 01.0411.6060 **Gourmetlöffel**

■ 11.0411.6040
190 mm/7 1/2 in.
gourmet spoon
cuiller à sauce
cuchara gourmet
cucchiaio gourmet



■ 01.0435.6062 **Fischgabel**

■ 11.0435.6042
183 mm/7 1/4 in.
fish fork
fourchette à poisson
tenedor pescado
forchetta pesce



■ 01.0435.6063 **Fischmesser**

■ 11.0435.6043
206 mm/8 in.
fish knife
couteau à poisson
cuchillo pescado
coltello pesce



■ 01.0440.6060 **Austerngabel**

■ 11.0440.6040
145 mm/5 3/4 in.
oyster fork
fourchette à huîtres
tenedor ostras
forchetta per ostriche



■ 01.0464.6060 **Kuchengabel**

■ 11.0464.6040
157 mm/6 1/4 in.
cake fork
fourchette à gâteau
tenedor lunch
forchetta per dolce



■ 01.0466.6069 **Brot- /**

■ 11.0466.6049
170 mm/6 2/4 in.
bread/butter knife**
couteau de table**
cuchillo lunch**
coltello per dolce**



■ 01.0472.6060 **Limolöffel**

■ 11.0472.6040
220 mm/8 3/4 in.
iced tea spoon
cuiller à soda
cuchara refresco
cucchiaio bibita



■ 01.0478.6069 **Steakmesser****

■ 11.0478.6049
230 mm/9 in.
steak knife**
couteau à steak**
cuchillo steak**
coltello da bistecca**



■ 01.0489.6060 **Tassenlöffel**

■ 11.0489.6040
166 mm/6 1/2 in.
round bowl soup spoon
cuiller à bouillon
cuchara sopa
cucchiaio da brodo



VPE 12 Stk. / Unit 12 pcs.

- perfekte Versilberung / perfectly silverplated
- Cromargan®, poliert / stainless 18/10, polished

* Hohlheft mit Wellenschliff / hollow-handled with serrated edge

** Klingenstahl mit Wellenschliff / monobloc with serrated edge



■ **01 0400 6060**
 perfekt versilbert
 perfectly silverplated
 chromage parfait
 plateado perfecto
 perfetta placcatura in argento

■ **11 0400 6040**
 Cromargan®, poliert
 Cromargan®, polished
 Cromargan®, poli
 Cromargan®, pulido
 Cromargan®, lucido

Bistro betont mit schlichtem Design und klaren Linien die unterschiedlichsten Arrangements auf ideale Weise – mit prägnanten, kreisrunden Löffelkellen als optischer Blickfang.

With its simple design and clear lines, Bistro is the ideal complement to all kinds of table arrangements. The spoons, with their striking, circular bowls are particularly eye-catching.

BISTRO
 0400





Kunstvoll.
Elaborate.

Dynamisch.
Dynamic.

Markant.
Striking.

FLAIR

■ 10.1101.6060
 ■ 12.1101.6040
Menuelöffel
 207 mm/8¹/₄ in.
 table spoon
 cuiller de table
 cuchara mesa
 cucchiaio tavola



■ 10.1102.6060
 ■ 12.1102.6040
Menuegabel
 205 mm/8 in.
 table fork
 fourchette de table
 tenedor mesa
 forchetta tavola



■ 10.1103.6067
 ■ 12.1103.6047
Menuemesser*
 237 mm/9¹/₂ in.
 table knife*
 couteau de table*
 cuchillo mesa*
 coltello tavola cutinato*



■ 10.1103.6069
 ■ 12.1103.6049
Menuemesser**
 230 mm/9 in.
 table knife**
 couteau de table**
 cuchillo mesa**
 coltello tavola cutinato**



■ 10.1104.6060
 ■ 12.1104.6040
Vorspeisenlöffel
 183 mm/7¹/₄ in.
 dessert spoon
 cuiller à dessert
 cuchara postre
 cucchiaio frutta



■ 10.1105.6060
 ■ 12.1105.6040
Vorspeisengabel
 181 mm/7 in.
 dessert fork
 fourchette à dessert
 tenedor postre
 forchetta frutta



■ 10.1106.6067
 ■ 12.1106.6047
**Vorspeisen-
 messer***
 214 mm/8¹/₂ in.
 dessert knife*
 couteau à dessert*
 cuchillo postre*
 coltello frutta*



■ 10.1106.6069
 ■ 12.1106.6049
**Vorspeisen-
 messer****
 207 mm/8¹/₄ in.
 dessert knife**
 couteau à dessert**
 cuchillo postre**
 coltello frutta**



■ 10.1107.6060
 ■ 12.1107.6040
Kaffeelöffel
 132 mm/5¹/₄ in.
 tea/coffee spoon
 cuiller à café
 cuchara café
 cucchiaio caffè/té



■ 10.1109.6060
 ■ 12.1109.6040
**Espresso- /
 Mokkalöffel**
 108 mm/4¹/₄ in.
 demi-tasse spoon
 cuiller à mocca
 cuchara moca
 cucchiaio moca



■ 10.1110.6060
 ■ 12.1110.6040
**Vorspeisen- /
 Dessertlöffel**
 156 mm/6 in.
 coffee/tea spoon, large
 cuiller à café/té, grande
 cuchara à café/té, grande
 cucchiaio caffè/té, grande



■ 10.1111.6060
 ■ 12.1111.6040
Gourmetlöffel
 190 mm/7¹/₂ in.
 gourmet spoon
 cuiller à sauce
 cuchara gourmet
 cucchiaio gourmet



■ 10.1135.6062
 ■ 12.1135.6042
Fischgabel
 183 mm/7¹/₄ in.
 fish fork
 fourchette à poisson
 tenedor pescado
 forchetta pesce



■ 10.1135.6063
 ■ 12.1135.6043
Fischmesser
 206 mm/8 in.
 fish knife
 couteau à poisson
 cuchillo pescado
 coltello pesce



■ 10.1140.6060
 ■ 12.1140.6040
Austerngabel
 149 mm/5⁷/₈ in.
 oyster fork
 fourchette à huîtres
 tenedor ostras
 forchetta per ostriche



■ 10.1164.6060
 ■ 12.1164.6040
Kuchengabel
 157 mm/6¹/₄ in.
 cake fork
 fourchette à gâteau
 tenedor lunch
 forchetta per dolce



■ 10.1166.6069
 ■ 12.1166.6049
**Brot- /
 Buttermesser****
 170 mm/6⁷/₈ in.
 bread/butter knife**
 couteau de table**
 cuchillo lunch**
 coltello per dolce**



■ 10.1172.6060
 ■ 12.1172.6040
Limolöffel
 220 mm/8³/₄ in.
 iced tea spoon
 cuiller à soda
 cuchara refresco
 cucchiaio bibita



■ 10.1178.6069
 ■ 12.1178.6049
Steakmesser**
 226 mm/9 in.
 steak knife**
 couteau à steak**
 cuchillo steak**
 coltello da bistecca**



■ 10.1189.6060
 ■ 12.1189.6040
Tassenlöffel
 166 mm/6¹/₂ in.
 round bowl soup spoon
 cuiller à bouillon
 cuchara sopa
 cucchiaio da brodo



VPE 12 Stk. / Unit 12 pcs.

- perfekte Versilberung / perfectly silverplated
- Cromargan®, poliert / stainless 18/10, polished

* Hohlheft mit Wellenschliff / hollow-handled with serrated edge

** Klingenstahl mit Wellenschliff / monobloc with serrated edge



■ **10 1100 6060**
 perfekt versilbert
 perfectly silverplated
 chromage parfait
 plateado perfecto
 perfetta placcatura in argento

■ **12 1100 6040**
 Cromargan®, poliert
 Cromargan®, polished
 Cromargan®, poli
 Cromargan®, pulido
 Cromargan®, lucido

Flair ist mit seinen spitz zulaufenden Griffen und filigranem Dekor ein aufmerksamkeitsstarkes Element auf dem gedeckten Tisch. Das filigrane Dekor geht eine perfekte Symbiose mit funktionalem Design ein.

With its tapered handles and elegant decorative elements, Flair is a striking addition to any well-laid table. This collection is a perfect combination of elegance and functional design.

FLAIR
 1100





Agil.
Agile.

Zurückhaltend.
Restrained.

Grazil.
Graceful.

CLUB

■ 11.4701.6040

Menuelöffel

199 mm/8 in.
table spoon
cuiller de table
cuchara mesa
cucchiaio tavola



■ 11.4702.6040

Menuegabel

197 mm/7 3/4 in.
table fork
fourchette de table
tenedor mesa
forchetta tavola



■ 11.4703.6047

Menuemesser*

217 mm/8 1/2 in.
table knife*
couteau de table*
cuchillo mesa*
coltello tavola cutinato*



■ 11.4703.6049

Menuemesser**

215 mm/8 1/2 in.
table knife**
couteau de table**
cuchillo mesa**
coltello tavola cutinato**



■ 11.4704.6040

Vorspeisenlöffel

183 mm/7 1/4 in.
dessert spoon
cuiller à dessert
cuchara postre
cucchiaio frutta



■ 11.4705.6040

Vorspeisengabel

181 mm/7 1/4 in.
dessert fork
fourchette à dessert
tenedor postre
forchetta frutta



■ 11.4706.6047

**Vorspeisen-
messer***

201 mm/8 in.
dessert knife*
couteau à dessert*
cuchillo postre*
coltello frutta*



■ 11.4706.6049

**Vorspeisen-
messer****

197 mm/7 3/4 in.
dessert knife**
couteau à dessert**
cuchillo postre**
coltello frutta**



■ 11.4707.6040

Kaffeelöffel

132 mm/5 1/4 in.
tea/coffee spoon
cuiller à café
cuchara café
cucchiaio caffè/té



■ 11.4709.6040

**Espresso- /
Mokkalöffel**

108 mm/4 1/4 in.
demi-tasse spoon
cuiller à moca
cuchara moca
cucchiaio moca



■ 11.4710.6040

**Vorspeisen- /
Dessertlöffel**

156 mm/6 1/4 in.
coffee/tea spoon, large
cuiller à café/té, grande
cuchara lunch
cucchiaio caffè/té, grande



■ 11.4711.6040

Gourmetlöffel

186 mm/7 1/4 in.
gourmet spoon
cuiller à sauce
cuchara gourmet
cucchiaio gourmet



■ 11.4735.6042

Fischgabel

183 mm/7 1/4 in.
fish fork
fourchette à poisson
tenedor pescado
forchetta pesce



■ 11.4735.6043

Fischmesser

206 mm/8 in.
fish knife
couteau à poisson
cuchillo pescado
coltello pesce



■ 11.4740.6040

Austerngabel

146 mm/5 3/4 in.
oyster fork
fourchette à huîtres
tenedor ostras
forchetta per ostriche



■ 11.4764.6040

Kuchengabel

157 mm/6 1/4 in.
cake fork
fourchette à gâteau
tenedor lunch
forchetta per dolce



■ 11.4766.6049

**Brot- /
Buttermesser****

170 mm/6 3/4 in.
bread/butter knife**
couteau de table**
cuchillo lunch**
coltello per dolce**



■ 11.4772.6040

Limolöffel

220 mm/8 3/4 in.
iced tea spoon
cuiller à soda
cuchara refresco
cucchiaio bibita



■ 11.4778.6049

Steakmesser**

219 mm/8 3/4 in.
steak knife**
couteau à steak**
cuchillo steak**
coltello da bistecca**



■ 11.4789.6040

Tassenlöffel

166 mm/6 1/2 in.
round bowl soup spoon
cuiller à bouillon
cuchara sopa
cucchiaio da brodo



VPE 12 Stk. / Unit 12 pcs.

- Cromargan®, poliert / stainless 18/10, polished
- * Hohlheft mit Wellenschliff / hollow-handled with serrated edge
- ** Klingenstahl mit Wellenschliff / monobloc with serrated edge



■ 11 4700 6040
 Cromargan®, poliert
 Cromargan®, polished
 Cromargan®, poli
 Cromargan®, pulido
 Cromargan®, lucido

Club ist mit seiner flexiblen und gleichzeitig markanten Ästhetik ein Allround-Talent. Mit einer umlaufenden Schmucklinie eignet sich die Kollektion für einfach wie festlich gedeckte Tische.

With its flexible, yet striking aesthetics, Club is a real all-rounder. The decorative line around the edge makes this collection ideal for both simple and festively laid tables.

CLUB
 4700



























Ausdrucksstark.
Expressive.

Flexibel.
Flexible.

Überraschend.
Surprising.

BAGUETTE

- | | | | | | |
|--|---|--|--|--|---|
| <p>■ 01.0101.6060
■ 11.0101.6040</p>  | <p>Menuelöffel
211 mm/8¹/₄ in.
table spoon
cuiller de table
cuchara mesa
cucchiaio tavola</p> | <p>■ 01.0107.6060
■ 11.0107.6040</p>  | <p>Kaffeelöffel
147 mm/5⁷/₈ in.
tea/coffee spoon
cuiller à café
cuchara café
cucchiaio caffè/té</p> | <p>■ 01.0178.6067
■ 11.0178.6047</p>  | <p>Steakmesser*
220 mm/8⁵/₈ in.
steak knife*
couteau à steak*
cuchillo steak*
coltello da bistecca</p> |
| <p>■ 01.0102.6060
■ 11.0102.6040</p>  | <p>Menuegabel
211 mm/8¹/₄ in.
table fork
fourchette de table
tenedor mesa
forchetta tavola</p> | <p>■ 01.0109.6060
■ 11.0109.6040</p>  | <p>Espresso- / Mokkalöffel
114 mm/4¹/₂ in.
demi-tasse spoon
cuiller à moca
cuchara moca
cucchiaio moca</p> | <p>■ 11.0178.6049</p>  | <p>Steakmesser**
234 mm/9¹/₄ in.
steak knife**
couteau à steak**
cuchillo steak**
coltello da bistecca**</p> |
| <p>■ 01.0115.6061
■ 11.0115.6041</p>  | <p>Menuelöffel, klein
196 mm/7³/₄ in.
tasting spoon, small
cuiller de table, petit
cuchara menu, pequeño
cucchiaio menu, piccolo</p> | <p>■ 01.0110.6060
■ 11.0110.6040</p>  | <p>Vorspeisen- / Dessertlöffel
165 mm/6¹/₂ in.
coffee/tea spoon, large
cuiller à café/té, grande
cuchara à café/té, grande
cucchiaio caffè/té, grande</p> | <p>■ 01.0189.6060
■ 11.0189.6040</p>  | <p>Tassenlöffel
168 mm/6⁵/₈ in.
round bowl soup spoon
cuiller à bouillon
cuchara sopa
cucchiaio da brodo</p> |
| <p>■ 01.0115.6062
■ 11.0115.6042</p>  | <p>Menuegabel, klein
196 mm/7³/₄ in.
tasting fork, small
fourchette de table, petite
tenedor menu, pequeño
forchetta menu, piccolo</p> | <p>■ 01.0111.6060
■ 11.0111.6040</p>  | <p>Gourmetlöffel
186 mm/7³/₈ in.
gourmet spoon
cuiller à sauce
cuchara gourmet
cucchiaio gourmet</p> | | |
| <p>■ 01.0103.6067
■ 11.0103.6047</p>  | <p>Menuemesser*
231 mm/9 in.
table knife*
couteau de table*
cuchillo mesa*
coltello tavola cutinato*</p> | <p>■ 01.0135.6062
■ 11.0135.6042</p>  | <p>Fischgabel
179 mm/7 in.
fish fork
fourchette à poisson
tenedor pescado
forchetta pesce</p> | | |
| <p>■ 01.0103.6069
■ 11.0103.6049</p>  | <p>Menuemesser**
231 mm/9 in.
table knife**
couteau de table**
cuchillo mesa**
coltello tavola cutinato**</p> | <p>■ 01.0135.6063
■ 11.0135.6043</p>  | <p>Fischmesser
215 mm/8⁵/₈ in.
fish knife
couteau à poisson
cuchillo pescado
coltello pesce</p> | | |
| <p>■ 01.0104.6060
■ 11.0104.6040</p>  | <p>Vorspeisenlöffel
183 mm/7¹/₄ in.
dessert spoon
cuiller à dessert
cuchara postre
cucchiaio frutta</p> | <p>■ 01.0140.6060
■ 11.0140.6040</p>  | <p>Austerngabel
141 mm/5¹/₂ in.
oyster fork
fourchette à huîtres
tenedor ostras
forchetta per ostriche</p> | | |
| <p>■ 01.0105.6060
■ 11.0105.6040</p>  | <p>Vorspeisengabel
179 mm/7 in.
dessert fork
fourchette à dessert
tenedor postre
forchetta frutta</p> | <p>■ 01.0164.6060
■ 11.0164.6040</p>  | <p>Kuchengabel
163 mm/6¹/₂ in.
cake fork
fourchette à gâteau
tenedor lunch
forchetta per dolce</p> | | |
| <p>■ 01.0106.6067
■ 11.0106.6047</p>  | <p>Vorspeisenmesser*
214 mm/8³/₈ in.
dessert knife*
couteau à dessert*
cuchillo postre*
coltello frutta*</p> | <p>■ 01.0166.6069
■ 11.0166.6049</p>  | <p>Brot- / Buttermesser**
170 mm/6²/₈ in.
bread/butter knife**
couteau de table**
cuchillo lunch**
coltello per dolce**</p> | | |
| <p>■ 01.0106.6069
■ 11.0106.6049</p>  | <p>Vorspeisenmesser**
214 mm/8³/₈ in.
dessert knife**
couteau à dessert**
cuchillo postre**
coltello frutta**</p> | <p>■ 01.0172.6060
■ 11.0172.6040</p>  | <p>Limolöffel
220 mm/8³/₄ in.
iced tea spoon
cuiller à soda
cuchara refresco
cucchiaio bibita</p> | | |

VPE 12 Stk. / Unit 12 pcs.

■ perfekte Versilberung / perfectly silverplated

■ Cromargan®, poliert / stainless 18/10, polished

* Hohlheft mit Wellenschliff / hollow-handled with serrated edge

** Klingenstahl mit Wellenschliff / monobloc with serrated edge



■ **01 0100 6060**
 perfekt versilbert
 perfectly silverplated
 chromage parfait
 plateado perfecto
 perfetta placcatura in argento

■ **11 0100 6040**
 Cromargan®, poliert
 Cromargan®, polished
 Cromargan®, poli
 Cromargan®, pulido
 Cromargan®, lucido

Baguette verfügt dank seiner beeindruckenden Größe über besondere Prägnanz. Die markanten Kerben und erhabenen Oberflächen setzen plastische Akzente.

Thanks to its impressive size, Baguette makes a particularly striking impact. Characteristic notches and raised surfaces give this collection a sculpted look.

BAGUETTE

0100



























Geometrisch.
Geometric.

Hochwertig.
Classy.

Unabhängig.
Independent.

MONDIAL

- | | | | | | |
|--|---|--|---|--|--|
| <p>■ 10.6201.6060
■ 12.6201.6040</p>  | <p>Menuelöffel
203 mm/8 in.
table spoon
cuiller de table
cuchara mesa
cucchiaio tavola</p> | <p>■ 10.6207.6060
■ 12.6207.6040</p>  | <p>Kaffeelöffel
132 mm/5 1/4 in.
tea/coffee spoon
cuiller à café
cuchara café
cucchiaio caffè/té</p> | <p>■ 10.6278.6069
■ 12.6278.6049</p>  | <p>Steakmesser**
229 mm/9 in.
steak knife**
couteau à steak**
cuchillo steak**
coltello da bistecca**</p> |
| <p>■ 10.6202.6060
■ 12.6202.6040</p>  | <p>Menuegabel
201 mm/8 in.
table fork
fourchette de table
tenedor mesa
forchetta tavola</p> | <p>■ 10.6209.6060
■ 12.6209.6040</p>  | <p>Espresso- / Mokkalöffel
108 mm/4 1/4 in.
demi-tasse spoon
cuiller à moca
cuchara moca
cucchiaio moca</p> | <p>■ 10.6289.6060
■ 12.6289.6040</p>  | <p>Tassenlöffel
166 mm/6 1/2 in.
round bowl soup spoon
cuiller à bouillon
cuchara sopa
cucchiaio da brodo</p> |
| <p>■ 12.6202.6042</p>  | <p>Menuegabel, lang
210 mm/8 1/2 in.
table fork, long
fourchette de table, longue
tenedor mesa, largo
forchetta tavola, lungo</p> | <p>■ 10.6210.6060
■ 12.6210.6040</p>  | <p>Vorspeisen- / Dessertlöffel
156 mm/6 1/4 in.
coffee/tea spoon, large
cuiller à café/té, grande
cuchara à café/té, grande
cucchiaio caffè/té, grande</p> | | |
| <p>■ 10.6203.6067
■ 12.6203.6047</p>  | <p>Menuemesser*
232 mm/9 1/4 in.
table knife*
couteau de table*
cuchillo mesa*
coltello tavola cutinato*</p> | <p>■ 10.6211.6060
■ 12.6211.6040</p>  | <p>Gourmetlöffel
186 mm/7 3/8 in.
gourmet spoon
cuiller à sauce
cuchara gourmet
cucchiaio gourmet</p> | | |
| <p>■ 10.6203.6069
■ 12.6203.6049</p>  | <p>Menuemesser**
229 mm/9 in.
table knife**
couteau de table**
cuchillo mesa**
coltello tavola cutinato**</p> | <p>■ 10.6235.6062
■ 12.6235.6042</p>  | <p>Fischgabel
183 mm/7 1/4 in.
fish fork
fourchette à poisson
tenedor pescado
forchetta pesce</p> | | |
| <p>■ 12.6233.6049</p>  | <p>Menuemesser**, lang
240 mm/9 1/2 in.
table knife**, long
couteau de table**, long
cuchillo mesa**, largo
coltello tavola**, lungo</p> | <p>■ 10.6235.6063
■ 12.6235.6043</p>  | <p>Fischmesser
206 mm/8 in.
fish knife
couteau à poisson
cuchillo pescado
coltello pesce</p> | | |
| <p>■ 10.6204.6060
■ 12.6204.6040</p>  | <p>Vorspeisenlöffel
187 mm/7 3/8 in.
dessert spoon
cuiller à dessert
cuchara postre
cucchiaio frutta</p> | <p>■ 10.6240.6060
■ 12.6240.6040</p>  | <p>Austerngabel
138 mm/5 1/2 in.
oyster fork
fourchette à huîtres
tenedor ostras
forchetta per ostriche</p> | | |
| <p>■ 10.6205.6060
■ 12.6205.6040</p>  | <p>Vorspeisengabel
185 mm/7 3/8 in.
dessert fork
fourchette à dessert
tenedor postre
forchetta frutta</p> | <p>■ 10.6264.6060
■ 12.6264.6040</p>  | <p>Kuchengabel
157 mm/6 1/8 in.
cake fork
fourchette à gâteau
tenedor lunch
forchetta per dolce</p> | | |
| <p>■ 10.6206.6067
■ 12.6206.6047</p>  | <p>Vorspeisenmesser*
213 mm/8 3/8 in.
dessert knife*
couteau à dessert*
cuchillo postre*
coltello frutta*</p> | <p>■ 10.6266.6069
■ 12.6266.6049</p>  | <p>Brot- / Buttermesser**
170 mm/6 3/4 in.
bread/butter knife**
couteau de table**
cuchillo lunch**
coltello per dolce**</p> | | |
| <p>■ 10.6206.6069
■ 12.6206.6049</p>  | <p>Vorspeisenmesser**
213 mm/8 3/8 in.
dessert knife**
couteau à dessert**
cuchillo postre**
coltello frutta**</p> | <p>■ 10.6272.6060
■ 12.6272.6040</p>  | <p>Limolöffel
220 mm/8 3/4 in.
iced tea spoon
cuiller à soda
cuchara refresco
cucchiaio bibita</p> | | |

VPE 12 Stk. / Unit 12 pcs.

■ perfekte Versilberung / perfectly silverplated

■ Cromargan®, poliert / stainless 18/10, polished

* Hohlheft mit Wellenschliff / hollow-handled with serrated edge

** Klingenstahl mit Wellenschliff / monobloc with serrated edge



■ **10 6200 6060**
 perfekt versilbert
 perfectly silverplated
 chromage parfait
 plateado perfecto
 perfetta placcatura in argento

■ **12 6200 6040**
 Cromargan®, poliert
 Cromargan®, polished
 Cromargan®, poli
 Cromargan®, pulido
 Cromargan®, lucido

Mondial akzentuiert mit seinem trapezförmigen Design klassische Arrangements auf einprägsame Weise. Dank der hochwertigen Verarbeitung passt die Serie besonders zu erlesenen Konzepten.

With its trapezoidal design, Mondial makes a memorable addition to classic table arrangements. Thanks to the high-quality workmanship, this collection is a particularly good fit with refined concepts.

MONDIAL
 6200



Menü

























Stattlich.
Majestic.

Klar.
Clear.

Variabel.
Versatile.

RESIDENCE

- | | | | | | |
|--|---|--|---|--|--|
| <p>■ 10.4801.6060
■ 12.4801.6040</p>  | <p>Menuelöffel
204 mm/8 in.
table spoon
cuiller de table
cuchara mesa
cucchiaio tavola</p> | <p>■ 10.4807.6060
■ 12.4807.6040</p>  | <p>Kaffeelöffel
132 mm/5 1/4 in.
tea/coffee spoon
cuiller à café
cuchara café
cucchiaio caffè/té</p> | <p>■ 12.4878.6047</p>  | <p>Steakmesser*
220 mm/8 1/2 in.
steak knife*
couteau à steak*
cuchillo steak*
coltello da bistecca*</p> |
| <p>■ 10.4802.6060
■ 12.4802.6040</p>  | <p>Menuegabel
202 mm/8 in.
table fork
fourchette de table
tenedor mesa
forchetta tavola</p> | <p>■ 10.4809.6060
■ 12.4809.6040</p>  | <p>Espresso- / Mokkalöffel
108 mm/4 1/4 in.
demi-tasse spoon
cuiller à moca
cuchara moca
cucchiaio moca</p> | <p>■ 12.4878.6049</p>  | <p>Steakmesser**
228 mm/9 in.
steak knife**
couteau à steak**
cuchillo steak**
coltello da bistecca**</p> |
| <p>■ 12.4802.6042</p>  | <p>Menuegabel, lang
210 mm/8 1/2 in.
table fork, long
fourchette de table, longue
tenedor mesa, largo
forchetta tavola, lungo</p> | <p>■ 10.4810.6060
■ 12.4810.6040</p>  | <p>Vorspeisen- / Dessertlöffel
157 mm/6 1/4 in.
coffee/tea spoon, large
cuiller à café/té, grande
cuchara à café/té, grande
cucchiaio caffè/té, grande</p> | <p>■ 10.4889.6060
■ 12.4889.6040</p>  | <p>Tassenlöffel
166 mm/6 1/2 in.
round bowl soup spoon
cuiller à bouillon
cuchara sopa
cucchiaio da brodo</p> |
| <p>■ 10.4803.6067
■ 12.4803.6047</p>  | <p>Menuemesser*
226 mm/9 in.
table knife*
couteau de table*
cuchillo mesa*
coltello tavola cutinato*</p> | <p>■ 10.4811.6060
■ 12.4811.6040</p>  | <p>Gourmetlöffel
186 mm/7 1/4 in.
gourmet spoon
cuiller à sauce
cuchara gourmet
cucchiaio gourmet</p> | | |
| <p>■ 10.4803.6069
■ 12.4803.6049</p>  | <p>Menuemesser**
227 mm/9 in.
table knife**
couteau de table**
cuchillo mesa**
coltello tavola cutinato**</p> | <p>■ 10.4835.6062
■ 12.4835.6042</p>  | <p>Fischgabel
176 mm/7 in.
fish fork
fourchette à poisson
tenedor pescado
forchetta pesce</p> | | |
| <p>■ 12.4833.6049</p>  | <p>Menuemesser**, lang
240 mm/9 1/2 in.
table knife**, long
couteau de table**, long
cuchillo mesa**, largo
coltello tavola**, lungo</p> | <p>■ 10.4835.6063
■ 12.4835.6043</p>  | <p>Fischmesser
198 mm/7 3/4 in.
fish knife
couteau à poisson
cuchillo pescado
coltello pesce</p> | | |
| <p>■ 10.4804.6060
■ 12.4804.6040</p>  | <p>Vorspeisenlöffel
187 mm/7 1/4 in.
dessert spoon
cuiller à dessert
cuchara postre
cucchiaio frutta</p> | <p>■ 10.4840.6060
■ 12.4840.6040</p>  | <p>Austerngabel
140 mm/5 1/2 in.
oyster fork
fourchette à huîtres
tenedor ostras
forchetta per ostriche</p> | | |
| <p>■ 10.4805.6060
■ 12.4805.6040</p>  | <p>Vorspeisengabel
186 mm/7 1/4 in.
dessert fork
fourchette à dessert
tenedor postre
forchetta frutta</p> | <p>■ 10.4864.6060
■ 12.4864.6040</p>  | <p>Kuchengabel
157 mm/6 1/4 in.
cake fork
fourchette à gâteau
tenedor lunch
forchetta per dolce</p> | | |
| <p>■ 10.4806.6067
■ 12.4806.6047</p>  | <p>Vorspeisenmesser*
212 mm/8 1/4 in.
dessert knife*
couteau à dessert*
cuchillo postre*
coltello frutta*</p> | <p>■ 10.4866.6069
■ 12.4866.6049</p>  | <p>Brot- / Buttermesser**
170 mm/6 3/4 in.
bread/butter knife**
couteau de table**
cuchillo lunch**
coltello per dolce**</p> | | |
| <p>■ 10.4806.6069
■ 12.4806.6049</p>  | <p>Vorspeisenmesser**
212 mm/8 1/4 in.
dessert knife**
couteau à dessert**
cuchillo postre**
coltello frutta**</p> | <p>■ 10.4872.6060
■ 12.4872.6040</p>  | <p>Limolöffel
220 mm/8 3/4 in.
iced tea spoon
cuiller à soda
cuchara refresco
cucchiaio bibita</p> | | |

VPE 12 Stk. / Unit 12 pcs.

■ perfekte Versilberung / perfectly silverplated

■ Cromargan®, poliert / stainless 18/10, polished

* Hohlheft mit Wellenschliff / hollow-handled with serrated edge

** Klingenstahl mit Wellenschliff / monobloc with serrated edge



■ **10 4800 6060**
 perfekt versilbert
 perfectly silverplated
 chromage parfait
 plateado perfecto
 perfetta placcatura in argento

■ **12 4800 6040**
 Cromargan®, poliert
 Cromargan®, polished
 Cromargan®, poli
 Cromargan®, pulido
 Cromargan®, lucido

Residence interpretiert den Barockstil auf neue Weise. In auserlesenen Tisch-Arrangements mit modernem Touch kommt die Schönheit der klaren Linienführung besonders zur Geltung.

Residence takes the baroque style in a new direction. Sophisticated table arrangements with a modern touch really emphasize the beauty of its clear lines.

RESIDENCE
 4800





Formvollendet.
Accomplished.

Stilsicher.
Stylish.

Einprägsam.
Memorable.

METROPOLITAN

■ 10.5401.6060 **Menuelöffel**

■ 12.5401.6040
199 mm/8 in.
table spoon
cuiller de table
cuchara mesa
cucchiaio tavola



■ 10.5402.6060 **Menuegabel**

■ 12.5402.6040
197 mm/7 1/2 in.
table fork
fourchette de table
tenedor mesa
forchetta tavola



■ 10.5403.6067 **Menuemesser***

■ 12.5403.6047
216 mm/8 1/2 in.
table knife*
couteau de table*
cuchillo mesa*
coltello tavola cutinato*



■ 10.5403.6069 **Menuemesser****

■ 12.5403.6049
215 mm/8 1/2 in.
table knife**
couteau de table**
cuchillo mesa**
coltello tavola cutinato**



■ 10.5404.6060 **Vorspeisenlöffel**

■ 12.5404.6040
187 mm/7 1/2 in.
dessert spoon
cuiller à dessert
cuchara postre
cucchiaio frutta



■ 10.5405.6060 **Vorspeisengabel**

■ 12.5405.6040
185 mm/7 1/4 in.
dessert fork
fourchette à dessert
tenedor postre
forchetta frutta



■ 10.5406.6067 **Vorspeisen-
messer***

■ 12.5406.6047
205 mm/8 in.
dessert knife*
couteau à dessert*
cuchillo postre*
coltello frutta*



■ 10.5406.6069 **Vorspeisen-
messer****

■ 12.5406.6049
205 mm/8 in.
dessert knife**
couteau à dessert**
cuchillo postre**
coltello frutta**



■ 10.5407.6060 **Kaffeelöffel**

■ 12.5407.6040
132 mm/5 1/4 in.
tea/coffee spoon
cuiller à café
cuchara café
cucchiaio caffè/té



■ 10.5409.6060 **Espresso- /
Mokkalöffel**

■ 12.5409.6040
108 mm/4 1/4 in.
demi-tasse spoon
cuiller à moca
cuchara moca
cucchiaio moca



■ 10.5410.6060 **Vorspeisen- /
Dessertlöffel**

■ 12.5410.6040
156 mm/6 1/4 in.
coffee/tea spoon, large
cuiller à café/té, grande
cuchara à café/té, grande
cucchiaio caffè/té, grande



■ 10.5411.6060 **Gourmetlöffel**

■ 12.5411.6040
191 mm/7 1/2 in.
gourmet spoon
cuiller à sauce
cuchara gourmet
cucchiaio gourmet



■ 10.5435.6062 **Fischgabel**

■ 12.5435.6042
177 mm/7 in.
fish fork
fourchette à poisson
tenedor pescado
forchetta pesce



■ 10.5435.6063 **Fischmesser**

■ 12.5435.6043
199 mm/8 in.
fish knife
couteau à poisson
cuchillo pescado
coltello pesce



■ 10.5440.6060 **Austerngabel**

■ 12.5440.6040
141 mm/5 1/2 in.
oyster fork
fourchette à huîtres
tenedor ostras
forchetta per ostriche



■ 10.5464.6060 **Kuchengabel**

■ 12.5464.6040
157 mm/6 1/4 in.
cake fork
fourchette à gâteau
tenedor lunch
forchetta per dolce



■ 10.5466.6069 **Brot- /
Buttermesser****

■ 12.5466.6049
170 mm/6 2/4 in.
bread/butter knife**
couteau de table**
cuchillo lunch**
coltello per dolce**



■ 10.5472.6060 **Limolöffel**

■ 12.5472.6040
220 mm/8 3/4 in.
iced tea spoon
cuiller à soda
cuchara refresco
cucchiaio bibita



■ 12.5478.6047 **Steakmesser***

222 mm/8 3/4 in.
steak knife*
couteau à steak*
cuchillo steak*
coltello da bistecca*



■ 12.5478.6049 **Steakmesser****

229 mm/9 in.
steak knife**
couteau à steak**
cuchillo steak**
coltello da bistecca**



■ 10.5489.6060 **Tassenlöffel**

■ 12.5489.6040
166 mm/6 1/2 in.
round bowl soup spoon
cuiller à bouillon
cuchara sopa
cucchiaio da brodo



VPE 12 Stk. / Unit 12 pcs.

- perfekte Versilberung / perfectly silverplated
- Cromargan®, poliert / stainless 18/10, polished

* Hohlheft mit Wellenschliff / hollow-handled with serrated edge

** Klingenstahl mit Wellenschliff / monobloc with serrated edge



■ **10 5400 6060**
 perfekt versilbert
 perfectly silverplated
 chromage parfait
 plateado perfecto
 perfetta placcatura in argento

■ **12 5400 6040**
 Cromargan®, poliert
 Cromargan®, polished
 Cromargan®, poli
 Cromargan®, pulido
 Cromargan®, lucido

Metropolitan bereichert klassische Gedecke mit seiner formvollendeten Silhouette. Die Wellenelemente an den Stielenden machen die Kollektion zum unverwechselbaren Begleiter unterschiedlichster Porzellanteile.

Metropolitan enhances classic table settings with its perfect silhouette. The wavy elements on the handle ends make this collection an unmistakable companion to all manner of porcelain items.

METROPOLITAN

5400

Chafing Dish – Besteck

chafing dish serving set
service pour chafing dish
cubierto servir chafing dish
posate chafing dish

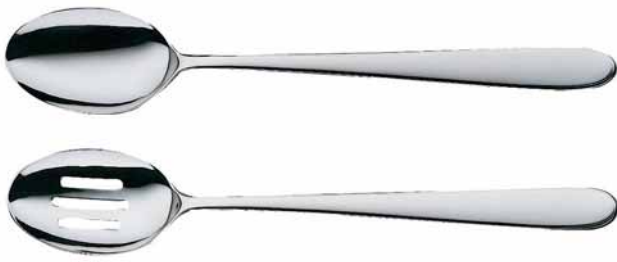

	Länge cm	length in.	Cromargan® stainless 18/10	versilbert silverplated
Chafing Dish Löffel / chafing dish spoon	39	15 1/4	12.8387.6041	10.8387.6061*
Chafing Dish Gabel / chafing dish fork	39	15 1/4	12.8387.6042	10.8387.6062*

* VPE 12 Stk. / Unit 12 pcs.

Salat-/Vorlegebesteck

salad/buffet serving set
couvert à salade/servir
cubierto ensalada/servir
posate servire insalata



	Länge cm	length in.	Cromargan® stainless 18/10	versilbert silverplated
Chafing Dish Löffel / chafing dish spoon	26	10 1/4	12.8386.6041	10.8386.6061*
Chafing Dish Gabel / chafing dish fork	26	10 1/4	12.8386.6042	
Chafing Dish Gabel / chafing dish fork	26	10 1/4	12.8249.6040	10.8249.6060*
Salatgabel / salad fork	26	10 1/4	12.8343.6042	10.8343.6062*

* VPE 12 Stk. / Unit 12 pcs.

Chafing Dish – Besteck

chafing dish serving set
service pour chafing dish
cubierto servir chafing dish
posate chafing dish



Hohlheftgriff /
hollow-handled

Cromargan® / stainless 18/10

	Länge cm	length in.	
Chafing Dish Löffel / chafing dish spoon	32,5	12 3/4	12.8381.6041
Chafing Dish Gabel / chafing dish fork	32,5	12 3/4	12.8381.6042

Fleischgabel

serving fork
fourchette à viande
tenedor carne
forchetta da antipasto



Hohlheftgriff /
hollow-handled

Cromargan® / stainless 18/10

Länge cm	length in.	
32,5	12 3/4	12.8382.6040



Nudellöffel

pasta serving spoon
cuillère à spaghetti
cuchara pasta
cuchiao per pasta

Hohlheftgriff /
hollow-handled

Cromargan® / stainless 18/10

Länge	length
cm	in.
31,5	12 ¹ / ₂

12.8383.6040



Salatzange

salad serving tongs
pince à salade
pinza para ensalada
pinza servire insalata

Länge	length
cm	in.
31	12 ¹ / ₄

Cromargan®	versilbert
stainless 18/10	silverplated
12.8341.6040	10.8341.6060*

* VPE 12 Stk. / Unit 12 pcs.



Salatzange

salad serving tongs
pince à salade
pinza para ensalada
pinza servire insalata

Cromargan® / stainless 18/10

Länge	length
cm	in.
30,5	12

12.8306.6040



Universalzange Prof. Wagenfeld

pastry serving tongs
pince à gâteau
pinza pasteles
pinza universale

Länge	length
cm	in.
20,5	8

Cromargan®	versilbert
mattiert	silverplated
stainless 18/10, satin finished	
12.8246.6030	10.8246.6060*

* VPE 12 Stk. / Unit 12 pcs.



Universalzange

pastry serving tongs
pince à gâteau
pinza pasteles
pinza universale

Cromargan® / stainless 18/10

Länge	length
cm	in.
23	9

54.9906.6040



Eiszange

ice tongs
pince à glace
pinza hielo
pinza per ghiaccio

Länge	length
cm	in.
17,3	6 ³ / ₄

Cromargan®	versilbert
stainless 18/10	silverplated
12.8307.6040	10.8307.6060*

* VPE 12 Stk. / Unit 12 pcs.



Gebäck- und Servierzange

pastry serving tongs
pince à gâteau
pinza pasteles
pinza servire per dolci

Cromargan® teilmattiert / stainless 18/10 partly satin finished

Länge	length
cm	in.
17	6 ³ / ₄

12.8362.6040



Zuckerzange

sugar tongs
pince à sucre
pinza de azucar
pinza per zucchero

Länge	length
cm	in.
10,7	4 ¹ / ₄

Cromargan®	versilbert
stainless 18/10	silverplated
12.8342.6040	10.8342.6060*

* VPE 12 Stk. / Unit 12 pcs.



Hummergabel

lobster fork
fourchette à homard
tenedor bogavante
forchetta aragosta

Länge	length
cm	in.
23,5	9 ¹ / ₄

Cromargan®	versilbert
stainless 18/10	silverplated
12.8336.6040	10.8336.6060*

* VPE 12 Stk. / Unit 12 pcs.



Hummerzange

lobster-crack
pince à homard
pinza para langostas
pinza per aragoste

Chromstahl / chrome steel

Länge	length
cm	in.
19,8	7 ³ / ₄

12.8410.6040



Schneckengabel

snail fork
fourchette à escargots
tenedor caracoles
forchetta per lumache

Länge	length
cm	in.
14,5	5 ³ / ₄

Cromargan®	versilbert
stainless 18/10	silverplated
12.8335.6040	10.8335.6060*

* VPE 12 Stk. / Unit 12 pcs.



Schneckenzange

snail tweezer
pince à escargots
pinza caracoles
pinza per lumache

Cromargan® / stainless 18/10

Länge	length
cm	in.
15	6

12.8291.6040



Dressinglöffel

dressing ladle
cuiller à sauce
cazo salsa
mestolino salsa

Cromargan® / stainless 18/10

Länge	length	Inhalt	cap.	Ø	Ø	
cm	in.	Ltr.	oz.	cm	in.	
26	10 ¹ / ₄	0,03	1,05	6,5	2 ¹ / ₂	12.8207.6040



Bowlenlöffel

punch bowl ladle
cuiller à punch
cazo ponche
cucchiaio per bowl

Cromargan® / stainless 18/10

Länge	length	Inhalt	cap.	
cm	in.	Ltr.	oz.	
40	15 ³ / ₄	0,08	2,70	12.8344.6040



Saucenlöffel

gravy ladle
cuiller à sauce
cazo salsa
mestolino salsa

Cromargan® / stainless 18/10

Länge	length	Inhalt	cap.	
cm	in.	Ltr.	oz.	
18	7	0,03	1,05	12.8395.6040



Portionsschöpfer

soup ladle, medium
louche, medium
cazo porciones
ramaiolo, medio

Cromargan® / stainless 18/10

Länge	length	Inhalt	cap.	
cm	in.	Ltr.	oz.	
26,4	10 ¹ / ₂	0,06	2,03	12.8423.6040

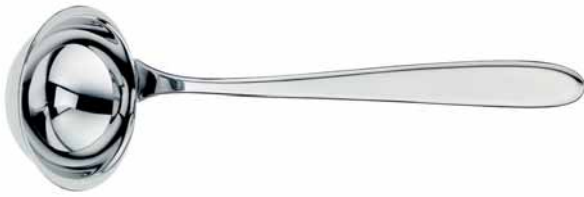

Suppenschöpfer

soup ladle
louche à potage
cazo sopa
ramaiole

Cromargan® / stainless 18/10

Länge	length	Inhalt	cap.
cm	in.	Ltr.	oz.
29,5	11 1/2	0,11	3,72

54.9904.6040



Kartoffellöffel

potato spoon
cuiller à pommes de terre
cucharon patatas
cucchiaio per patate

Cromargan® / stainless 18/10

Länge	length
cm	in.
21,5	8 1/2

12.8394.6040



Eisschaufel

ice-shovel
cuiller à glace
pala para hielo
cucchianino per gelato

Cromargan® / stainless 18/10

Länge	length
cm	in.
13,8	5 1/2

12.8057.6040*

* VPE 12 Stk. / unit 12 pcs.



Eierlöffel

egg spoon
cuiller à oeuf
cuchara huevos
cucchiaio per uovo

Cromargan® / stainless 18/10

Länge	length
cm	in.
13	5

12.9008.6040*

* VPE 12 Stk. / unit 12 pcs.



Vorlege-/ Aufschnittgabel

serving fork
fourchette à viande
tenedor carne
forchetta da antipasto

Cromargan® / stainless 18/10

Länge	length
cm	in.
19	7½

12.8393.6040



**Brotmesser
GRAND GOURMET**

bread knife
couteau à pain
cuchillo pan
coltello pane

Spezialklingenstahl, Cromargan® /
special blade steel, stainless 18/10

Länge	length
cm	in.
32	12½

18.8950.6032



**Brotmesser
SPITZENKLASSE PLUS**

bread knife
couteau à pain
cuchillo pan
coltello pane

Spezialklingenstahl, Cromargan® /
special blade steel, stainless 18/10

Länge	length
cm	in.
31,5	12½

18.8976.6032



**Tranchiermesser
GRAND GOURMET**

carving knife
couteau à viande
cuchillo carne
coltello carne

Spezialklingenstahl, Cromargan® /
special blade steel, stainless 18/10

Gesamtlänge	total length	Klingenlänge	length of blade
cm	in.	cm	in.
32,5	12¾	20	8

18.8948.6032



**Tranchiergabel
GRAND GOURMET**

meat fork
fourchette à viande
tenedor carne
forchettone

Cromargan® / stainless 18/10

Gesamtlänge cm	total length in.	Klingenlänge cm	length of blade in.
29	11 ¹ / ₂	14	5 ¹ / ₂

18.8957.6030



**Tranchiermesser
SPITZENKLASSE PLUS**

carving knife
couteau à viande
cuchillo carne
coltello carne

Spezialklingenstahl, Cromargan® /
special blade steel, stainless 18/10

Gesamtlänge cm	total length in.	Klingenlänge cm	length of blade in.
32	12 ¹ / ₂	20	8

18.9582.6032



**Tranchiergabel
SPITZENKLASSE PLUS**

meat fork
fourchette à viande
tenedor carne
forchettone

Spezialklingenstahl, Cromargan® /
special blade steel, stainless 18/10

Gesamtlänge cm	total length in.	Klingenlänge cm	length of blade in.
27	10 ³ / ₄	12	4 ³ / ₄

18.9588.6031



Steakbesteck SOLID

steak fork and knife SOLID
couvert à steak SOLID
cubierto steak SOLID
posate da bistecca SOLID

Cromargan® / stainless 18/10

	Länge cm	length in.	
Steakgabel SOLID / steak fork SOLID	21	8 ¹ / ₄	12.9013.6040
Steakmesser SOLID* / steak knife SOLID*	24,4	9 ³ / ₄	12.9014.6040*

* Hohlheft mit Wellenschliff / hollow-handled with serrated edge



Steakbesteck

steak flatware
couvert à steak
cubierto steak
posate da bistecca

Cromargan® / stainless 18/10

	Länge cm	length in.	
Steakgabel / steak fork	21	8 ¹ / ₄	12.8960.6042
Steakmesser / steak knife	23,1	9	12.8960.6049



Steakmesser

steak knife
couteau à steak
cuchillo steak
coltello da bistecca

Cromargan® / stainless 18/10

Länge cm	length in.	
20	8	12.8705.6047



Steakmesser*

steak knife*
couteau à steak*
cuchillo steak*
coltello da bistecca*

Cromargan®, poliert / stainless 18/10, polished

Länge mm	length in.	
220	8 ³ / ₄	11.0178.6047

* Hohlheft mit Wellenschliff / hollow-handled with serrated edge



Kaviarlöffel

caviar spoon
cuiller à caviar
cuchara caviar
cucchiaio per caviale

versilbert / silverplated

Länge cm	length in.	
20	8	01.0195.6062*

* VPE 12 Stk. / unit 12 pcs.



Kaviarmesser

caviar knife
couteau à caviar
cuchillo caviar
coltellino per caviale

versilbert / silverplated

Länge	length
cm	in.
21	8 ¹ / ₄

01.0195.6063*

* VPE 12 Stk. / unit 12 pcs.



Happy Spoon

happy spoon
happy spoon
happy spoon
happy spoon

in Menue- und Vorspeisengröße! /
in size table and dessert spoon!

Cromargan® / stainless 18/10

	Länge	length	
	cm	in.	
Happy Spoon	12,5	5	12.8993.6040
Happy Spoon S	11,5	4 ¹ / ₂	12.8345.6040

* VPE 12 Stk. / unit 12 pcs.



Tortenheber

pie server, large
pelle à gâteau, grande
pala tarta, grande
pala da torta, grande

Länge	length	Cromargan®	versilbert
cm	in.	stainless 18/10	silverplated
26	10 ¹ / ₄	12.8424.6040	10.8424.6060*

* VPE 12 Stk. / Unit 12 pcs.



Tortenmesser

cake knife
couteau à tarte
cuchillo tarta
coltello torta

Cromargan® / stainless 18/10

Länge	length
cm	in.
28	11

12.9163.6040



Käsemesser

cheese knife
couteau à fromage
cuchillo queso
coltello formaggio

Cromargan® / stainless 18/10

Länge	length
cm	in.
22	8 ³ / ₄

12.8861.6041



"4 for you" - Löffel

"4 for you" spoon
cuiller "4 for you"
cuchara "4 for you"
cucchiaio "4 for you"

Chromstahl / chrome steel

	Länge cm	length in.	
Gewürzlöffel (VPE 12 Stk.) / spicy spoon (unit 12 pcs.)	7	2 ³ / ₄	54.9184.6040
Espressolöffel / demi-tasse spoon	10,5	4 ¹ / ₄	12.9185.6040
Kaffeelöffel / coffee spoon	13,5	5 ¹ / ₄	12.9186.6040
Eiskaffeelöffel / iced tea spoon	19,5	7 ¹ / ₂	12.9188.6040

* VPE 12 Stk. / unit 12 pcs.



Löffel „KaffeeKultur“

spoons „KaffeeKultur“
cuillers „KaffeeKultur“
cucharas „KaffeeKultur“
cucchiai „KaffeeKultur“

Cromargan® / stainless 18/10

Länge	length	
mm	in.	
110	4 ¹ / ₄	54.9901.6040
136	5 ¹ / ₄	54.9902.6040
157	6 ¹ / ₄	54.9903.6040

* VPE 12 Stk. / unit 12 pcs.



Eislöffel XL

ice spoon XL
cuiller à glace XL
pala para hielo XL
cucchianino per gelato XL

Cromargan® / stainless 18/10

Länge	length
mm	in.
180	7

54.9905.6040*

* VPE 12 Stk. / unit 12 pcs.



Ess-Stäbchen Paar

ASIA

chopsticks pair
 baguettes paire
 juego de palillos
 paio bacchette

Cromargan®, POM Kunststoff / stainless 18/10, plastic

Länge	length
cm	in.
25,4	10

55.0122.6040



Ess-Stäbchen Ablage

ASIA

chopstick stand
 rangement pour baguettes
 soporte para palillos
 portaoggetti per bacchette

Cromargan® / stainless 18/10

Größe	size
cm	in.
8,4 x 1,7 x 1	3 1/4 x 3/4 x 1/2

55.0123.6040



Ess-Stäbchen Set

ASIA

chopstick set
 kit baguettes
 juego palillos
 set bacchette

bestehend aus: Ess-Stäbchen Paar, Ess-Stäbchen Ablage und
 Menueißel Nordic /
 consisting of: chopstick pair, chopstick stand and table spoon Nordic

Cromargan®, POM Kunststoff / stainless 18/10, plastic

Ess-Stäbchen Paar / chopsticks pair

Länge	length
cm	in.
25,4	10

55.0122.6040

Ess-Stäbchen Ablage / chopstick stand

Größe	size
cm	in.
8,4 x 1,7 x 1	3 1/4 x 3/4 x 1/2

55.0123.6040

Menueißel / table spoon

54.7201.6040

* Artikel einzeln zu bestellen / please order articles separately



Veredeltes Besteck. Über den Tellerrand hinaus.

Special-finish cutlery.
Getting a whole new take on things.

Stone-Washed. Steingewaschene Unikate.

Den charakteristischen „Used“- oder auch Antik-Look erhält Besteck, das dem Stone-Washing unterzogen wurde. Durch Schleifkörper, die seine Metalloberfläche wie kleine Feilen bearbeiten, entsteht der besondere unregelmäßige Materialabtrag. Danach sehen die einzelnen Besteckteile nur auf den ersten Blick genau gleich aus. Bei genauerer Betrachtung zeigt sich: Eigentlich ist jedes ein Unikat für sich.

Stone-washing. Stone-tumbled singularities.

Stone-washing gives cutlery a characteristic 'distressed' or 'aged' look. Tumbler stones are like tiny files acting on the surface of the metal, producing the effect of irregular abrasion. Consequently, it is only at first glance that individual items of cutlery look the same; closer inspection reveals that no two pieces are exactly alike.

Allen, die das Außergewöhnliche schätzen, bieten wir spezielle Formen der Veredelung unserer Besteckmodelle an. Die neu interpretierten Materialoberflächen schaffen das gewisse Etwas für Ihr Ambiente. Sie eignen sich für alle Modelle aus Cromargan®, sind spülmaschinenfest und liegen fernab von jedem Schubladendenken. Auch Vasen, Zuckerdosen oder Brotkörbe aus Edelstahl können auf diese Weise zu besonderen Stilelementen werden. Farbe, Material, Struktur – Ihre persönlichen Vorstellungen führen bei unseren individuell gefertigten Besteckveredelungen die Regie. Informationen zu Stückzahlen, Preisen und Lieferzeiten erhalten Sie daher auf Anfrage.

For those who appreciate the extraordinary, we offer special forms of finishing for our cutlery models. The re-interpreted material surfaces capture that certain something for your ambience. They are suitable for all Cromargan® models, are dishwasher-safe, and are anything but ordinary. The magic also turns stainless-steel flower vases, sugar bowls and bread baskets into eye-catching stylistic highlights. Color, material, structure – your personal preferences are what we work to for our cutlery custom-finishing processes. Consequently, detailed information about order volume, prices and delivery times is available on request.



Glasperle. Samtige Glanz- und Berührungspunkte.

Eine besonders zarte Form der Veredelung verleiht Bestecken eine seidenmatte und angenehm glatte Oberfläche. Bei der Methode des Glasperlenstrahlens werden mikroskopisch kleine Glaskugeln mit hohem Druck auf ein Besteckteil geblasen. Dadurch entsteht ein schimmerndes, gleichmäßiges Erscheinungsbild.

Glass bead. Velvety highlights and points of contact.

A supremely delicate technique of finishing affords cutlery a silky matte and charmingly smooth surface. Microscopically small glass beads are blasted at high pressure against an item of cutlery. The end effect is uniformly lustrous appearance.

PVD. Extraschicht für edle Optik.

Gold, Hellgold, Anthrazit und Kupfer Bronze auf Ihrer Tafel – die lebensmittelechten, metallischen Farben werden Schicht für Schicht im Vakuumverfahren aufgetragen. Sie sind für alle WMF Cromargan® Besteckmodelle geeignet. Hohlheft-Messer sind aus technischen Gründen von der Beschichtung ausgenommen. PVD, der Stoff aus dem die dekorativen Oberflächen-Verwandlungen sind, kommt übrigens aus der Schmuckindustrie.

PVD. Laid on additionally for quality good looks.

Gold, light gold, anthracite and copper-bronze on your table – the food-safe, metallic colors are applied layer by layer in the process known as physical vapour deposition, PVD. Colors and technique are suitable for all WMF Cromargan® cutlery models. For technical reasons, hollow-handle knives are excluded from the PVD process. PVD, the technique that produces these decorative surface alterations, was originally developed for the jewellery industry.

Table Top

table top







Mix & Match par excellence: Unterschiedlichste Materialien, Strukturen und Farben im Einklang

Mix & match through excellence:
a variety of different materials, structures
and colors in harmony

Der gedeckte Tisch im Restaurant ist die Bühne, auf der ein Koch beziehungsweise Gastronom seine kulinarischen Kreationen in Szene setzt. Gemeinsam mit der Tischdekoration bilden Porzellan, Besteck und Glas im Idealfall die perfekte Einheit für eine stilvolle Speisenpräsentation und unterstreichen darüber hinaus das gesamte Raumkonzept. Dabei hat sich ein Trend etabliert: Mix & Match. Schließlich will kein Stammgast im Hotel morgens, mittags und abends einen immer gleich eingedeckten Tisch sehen. Neben flexiblen Produkten, die vielfältige Kombinationsmöglichkeiten eröffnen, sorgen auffällige Strukturen oder Kontraste für Abwechslung. Mit zahlreichen Kollektionen, innovativen Verfahren der Individualisierung und kompetenter Beratung begleiten wir Sie auf dem Weg zur passenden Ausstattung – für Ihre Vision von Gastlichkeit.

Materialien im Mix

Zur Design-Philosophie von WMF zählt unter anderem, unterschiedliche Materialien miteinander in Einklang zu bringen. Ein gutes Beispiel dafür ist die Kollektion CultureCup: Metall, Porzellan und Glas bilden eine harmonische Einheit und können auf verschiedene Art und Weise arrangiert werden – ob ineinander verschlungen oder nebeneinander drapiert. Natürlich können auch einzelne Artikel unterschiedlicher WMF Kollektionen kombiniert werden. Der Kreativität sind keine Grenzen gesetzt, so dass wir Ihre individuellen Vorstellungen von Tischkultur umsetzen können.



Strukturen und Farben als Akzent

Prädestiniert für Mix & Match sind außerdem Bestecke und Tisch-Accessoires aus Edelstahl mit außergewöhnlichen Oberflächen. Unsere Methode „Stone-Washing“ verleiht einen imposanten Vintage-Charakter, der besonders in Kombination mit rustikalem Porzellan wirkt. Die Behandlung mit Glasperlenstrahlen sorgt hingegen für eine zarte, seidenmatte Nuance auf dem gedeckten Tisch – und ist deshalb für edlere Arrangements bestens geeignet. Außerdem verfeinern auf Raum und Accessoires abgestimmte Farbtöne das Ambiente. Die Kombinationsmöglichkeiten aus unserem umfangreichen Pure Exclusiv Sortiment sind vielseitig und werden Ihren Wünschen entsprechend hergestellt – ein Service der bereits für geringe Stückzahlen gilt.

In a restaurant the laid table provides the stage where the chef or gastronome can show his culinary creations. Together with the table decoration, the porcelain, cutlery and glass come together to create perfect unity for the stylish presentation of dishes, while emphasising the entire spatial concept.

A trend has established: mix & match. Ultimately, hotel guests do not wish to see their table laid in exactly the same way for breakfast, lunch and dinner. Besides flexible products that offer many possible combinations; eye-catching structures or contrasts provide variety. With numerous collections, innovative customisation methods and competent advice, we can help you along your way to finding the ideal equipment – for your hospitality vision.



NEU NEW

Materials in the mix

The WMF design philosophy includes finding a harmonious balance between the different materials. A good example of this is the CultureCup collection: Metal, porcelain and glass create harmonious unity and can be arranged in many different ways – whether placed inside or next to each other. Individual items from different WMF collections can also be combined of course. Creativity has no limits, which means we can realise your individual concepts for tableware.

Structures and colors provide emphasis

Cutlery and table accessories made from stainless steel with unusual surfaces are also predestined for the mix & match trend. Our „stone washing“ method lends an imposing vintage character that is especially effective when combined with rustic porcelain. However, the treatment using glass bead blasting adds a delicate, silk matt touch to the table presentation – and is therefore perfect for more sophisticated table arrangements. Color tones that have been coordinated with the room and accessories also enhance the ambiance. The different combination options for our extensive Pure Exclusiv range are diverse and are customised to suit your individual requirements – a service that is already available for small quantities.



Café Crème-Set

CultureCup

café crème set
kit café crème
juego café-crème
set café crème

bestehend aus: 6 Tablettts, 6 Porzellantassen M hoch, 6 Griffe M hoch,
6 Gläser S, 6 Kaffeelöffel /
consisting of: 6 serving trays, 6 porcelain cups M high, 6 handles M
high, 6 glasses S, 6 tea/coffee spoons

Cromargan®, Glas, Porzellan /
stainless 18/10, glass, porcelain

55.0111.6040



Cappuccino-Set

CultureCup

cappuccino set
kit cappuccino
juego capuchino
set cappuccino

bestehend aus: 6 Tablettts, 6 Porzellantassen M flach, 6 Ringe M flach,
6 Kaffeelöffel /
consisting of: 6 serving trays, 6 porcelain cups M low, 6 rings M low,
6 tea/coffee spoons

Cromargan®, Porzellan / stainless 18/10, porcelain

55.0112.6040



Espresso-Set

CultureCup

espresso set
kit espresso
juego espresso
set da café espresso

bestehend aus: 6 Tablettts, 6 Porzellantassen S, 6 Griffe S, 6 Gläser S,
6 Espresso-/Mokkalöffel /
consisting of: 6 serving trays, 6 porcelain cups S, 6 handles S, 6 glasses
S, 6 demi-tasse spoons

Cromargan®, Glas, Porzellan /
stainless 18/10, glass, porcelain

55.0113.6040



Kakao-Set

CultureCup

cocoa set
kit cacao
juego cacao
set cacao

bestehend aus: 6 Tablettts, 6 Gläser L, 6 Griffe M hoch, 6 Kaffeelöffel /
consisting of: 6 serving trays, 6 glasses L, 6 handles M high, 6 tea/coffee
spoons

Cromargan®, Glas / stainless 18/10, glass

55.0260.6040



Latte Macchiato-Set

CultureCup

latte macchiato set
kit latte-macchiato
juego latte macchiato
set latte-macchiato

bestehend aus: 6 Tablett, 6 Gläser bedruckt mit „Latte“, 6 Muglöffel /
consisting of: 6 serving trays, 6 glasses printed with „Latte“, 6 mug
spoons

Cromargan®, Glas / stainless 18/10, glass

55.0116.6040



Allround "CultureCup-Set" (84 Teile!)

all-round "CultureCup Set", (84 pieces!)
kit "CultureCup" polyvalent, (84 pièces!)
juego universal para el "CultureCup", (84 piezas!)
set „CultureCup“ completo, (84 pezzi!)

Das Allround-Set umfasst alles, was Sie für eine Belegung des
Kaffeenumsatzes benötigen. Bestehend aus den unten aufgeführten
Produkten.

The all-round set includes everything you need to boost your coffee
sales. Consisting of the below listed items.

Cromargan®, Glas, Porzellan /
stainless 18/10, glass, porcelain

55.0117.6040

- | | |
|---------------------------|-------------------------|
| 12 Tablett | 12 serving trays |
| 12 Gläser S | 12 glasses S |
| 6 Porzellantassen M hoch | 6 porcelain cups M high |
| 6 Porzellantassen M flach | 6 porcelain cups M low |
| 6 Porzellantassen S | 6 porcelain cups S |
| 6 Griffe M hoch | 6 handles S |
| 6 Griffe M flach | 6 handles M high |
| 6 Griffe S | 6 handles M low |
| 6 Gläser LATTE | 6 glasses LATTE |
| 6 Muglöffel | 6 mug spoons |
| 6 Kaffeelöffel | 6 tea/coffee spoons |
| 6 Espressolöffel | 6 demi-tasse spoons |

Tablett CultureCup

serving tray
plateau de service
bandeja
vassoio

Cromargan® / stainless 18/10

Größe	size
cm	in.
19,8 x 10,7 x 2	7 ³ / ₄ x 4 ¹ / ₄ x 3 ³ / ₄

55.0115.6040





**Porzellantasse M hoch mit Griff
CultureCup**

porcelain cup M high with handle
tasse en porcelaine M haute avec anse
taza de procelana M alta con asa
tassa di porcellana M alta con maniglia

Cromargan®, Porzellan / stainless 18/10, porcelain

Höhe	height	Inhalt	cap.
cm	in.	Ltr.	oz.
8,7	3 1/2	0,24	8,1

Porzellantasse M hoch (VPE 6 Stk.) /
porcelain cup M high (unit 6 pcs.)

55.0111.9805

Griff M hoch (VPE 6 Stk.) / handle M high (unit 6 pcs.)

55.0111.6042

* Artikel einzeln bestellen / please order articles separately



**Porzellantasse M flach mit Griff
CultureCup**

porcelain cup M low with handle
tasse en porcelaine M plate avec anse
taza de procelana M baja con asa
tassa di porcellana M bassa con maniglia

Cromargan®, Porzellan / stainless 18/10, porcelain

Höhe	height	Inhalt	cap.
cm	in.	Ltr.	oz.
7,5	3	0,25	8,5

Porzellantasse M flach (VPE 6 Stk.) /
porcelain cup M low (unit 6 pcs.)

55.0112.9805

Griff M flach (VPE 6 Stk.) / handle M low (unit 6 pcs.)

55.0112.6042

* Artikel einzeln bestellen / please order articles separately



**Porzellantasse S mit Griff
CultureCup**

porcelain cup S with handle
tasse en porcelaine S avec anse
taza de procelana S con asa
tassa di porcellana S con maniglia

Cromargan®, Porzellan / stainless 18/10, porcelain

Höhe	height	Inhalt	cap.
cm	in.	Ltr.	oz.
6,9	2 3/4	0,08	2,7

Porzellantasse S (VPE 6 Stk.) / porcelain cup S (unit 6 pcs.)

55.0113.9805

Griff S (VPE 6 Stk.) / handle S (unit 6 pcs.)

55.0113.6042

* Artikel einzeln bestellen / please order articles separately



Glas L mit Griff

CultureCup

glass L with handle
verre L avec anse
vaso L con asa
bicchiere L con maniglia

Cromargan®, Glas / stainless 18/10, glass

Höhe	height	Inhalt	cap.
cm	in.	Ltr.	oz.
9,5	3 ³ / ₄	0,3	10,1

Glas L (VPE 6 Stk.) / glass L (unit 6 pcs.)

55.0260.9995

Griff M hoch (VPE 6 Stk.) / handle M high (unit 6 pcs.)

55.0111.6042

* Artikel einzeln bestellen / please order articles separately



Glas LATTE (VPE 6 Stk.)

glass LATTE (unit 6 pcs.)
verre LATTE (UV 6 pc.)
vaso LATTE (UV 6 p.)
bicchiere LATTE (UV 6 p.)

Gläser bedruckt mit „LATTE“ /
glasses printed with „LATTE“

Höhe	height	Inhalt	cap.	Ø	Ø
cm	in.	Ltr.	oz.	cm	in.
14,5	5 ³ / ₄	0,35	11,8	6,5	2 ¹ / ₂

55.0092.9990



Glas S (VPE 6 Stk.)

CultureCup

glass S (unit 6 pcs.)
verre S (UV 6 pc.)
vaso S (UV 6 p.)
bicchiere S (UV 6 p.)

nicht kombinierbar mit: Deckel mit Ausschnitt 55.0031.6040 /
not combinable with: lid with cut-out 55.0031.6040

Glas / glass

Höhe	height	Inhalt	cap.
cm	in.	Ltr.	oz.
7	2 ³ / ₄	0,09	3

55.0114.9995



Löffel „CultureCup“

spoons „CultureCup“
cuillers „CultureCup“
cucharas „CultureCup“
cucchiai „CultureCup“

Cromargan® / stainless 18/10

Länge	length
mm	in.
110	4¼
136	5¼
157	6¼

54.9901.6040
54.9902.6040
54.9903.6040

* VPE 12 Stk. / unit 12 pcs.



Deckel mit Ausschnitt

lid with cut-out
couvercle avec découpe
tapa con recorte
coperchio con punto aperto per cucchiaio

passend zu Glas S, Porzellantasse S, Sahnekännchen von KaffeeKultur und Porzellantasse S von CultureCup. / fitting for glass S, porcelain cup S, creamer of CoffeeCulture and porcelain cup S of CultureCup.

Cromargan® / stainless 18/10

Ø	Ø
cm	in.
6	2¼

55.0031.6040



**Porzellanbehälter
CultureCup**

porcelain dish
récipient en porcelaine
recipiente de porcelana
recipiente di porcellana

passend in Pure Exclusiv Einsätze und zu Deckel mit Ausschnitt / fitting in inserts Pure Exclusiv and to lid with cut-out

Cromargan®, Porzellan / stainless 18/10, porcelain

Höhe	height	Inhalt	cap.
cm	in.	Ltr.	oz.
6,6	2½	0,08	2,7

Porzellantasse S (VPE 6 Stk.) / porcelain cup S (unit 6 pcs.) **55.0113.9805**

Deckel mit Ausschnitt / lid with cut-out **55.0031.6040**

Espresso-/Mokkalöffel (VPE 12 Stk.) /
demi-tasse spoon (unit 12 pcs.) **54.9901.6040**

* Artikel einzeln bestellen / please order articles separately



Latte Macchiato-Set
KaffeeKultur

latte macchiato set
kit latte-macchiato
juego latte macchiato
set latte-macchiato

bestehend aus: 6 Tablette, 6 Gläser L bedruckt mit „Latte Macchiato“,
6 Ringe L, 6 Muglöffel /
consisting of: 6 serving trays, 6 glasses L printed with „Latte
Macchiato“, 6 rings L, 6 mug spoons

Cromargan®, Glas / stainless 18/10, glass

06.2516.6040



Milchkaffee-Set
KaffeeKultur

caffè Latte set
kit café au lait
juego café con leche
set café latte

bestehend aus: 6 Tablette, 6 Gläser L unbedruckt, 6 Griffe L,
6 Muglöffel /
consisting of: 6 serving trays, 6 glasses L unprinted, 6 handles L,
6 mug spoons

Cromargan®, Glas / stainless 18/10, glass

06.2519.6040



Espresso-Set
KaffeeKultur

espresso set
kit espresso
juego espresso
set da café espresso

bestehend aus: 6 Tablette, 6 Porzellantassen S, 6 Griffe S, 6 Gläser S,
6 Ringe S, 6 Espresso-/Mokkalöffel /
consisting of: 6 serving trays, 6 porcelain cups S, 6 handles S, 6 glasses
S, 6 rings S, 6 demi-tasse spoons

Cromargan®, Glas, Porzellan /
stainless 18/10, glass, porcelain

06.2518.6040



Café Crème-Set
KaffeeKultur

café crème set
kit café crème
juego café-crème
set café crème

bestehend aus: 6 Tablette, 6 Porzellantassen M, 6 Griffe M, 6 Gläser S,
6 Ringe S, 6 Kaffeelöffel /
consisting of: 6 serving trays, 6 porcelain cups M, 6 handles M,
6 glasses S, 6 rings S, 6 tea/coffee spoons

Cromargan®, Glas, Porzellan /
stainless 18/10, glass, porcelain

06.2517.6040



Café au Lait-Set
KaffeeKultur

café au lait set
kit café au lait
juego café con leche
set café au lait

bestehend aus: 6 Tablettts, 6 Milchkaffeeschalen, 6 Ringe XL, 6
Muglöffel /
consisting of: 6 serving trays, 6 milk coffee pots, 6 rings XL, 6 mug
spoons

Cromargan®, Porzellan / stainless 18/10, porcelain **06.2527.6040**



Doppel-Espresso-Set
KaffeeKultur

espresso double set
kit espresso double
juego espresso doble
set café espresso doppio

bestehend aus: 6 Tablettts, 6 Doppel-Espresso-Tassen, 6 Griffe S, 6 Gläser
S, 6 Ringe S, 6 Espressolöffel /
consisting of: 6 serving trays, 6 cups Espresso double, 6 handles S, 6
glasses S, 6 rings S, 6 demi-tasse spoons

Cromargan®, Glas, Porzellan /
stainless 18/10, glass, porcelain **55.0043.6040**



Allround "KaffeeKultur-Set" (über 100 Teile!)

all-round "KaffeeKultur Set", (over 100 pieces!)
kit "KaffeeKultur" polyvalent, (plus de 100 pièces!)
juego universal para el "KaffeeKultur", (más de 100 piezas!)
set „KaffeeKultur“ completo, (più di 100 pezzi!)

Das Allround-Set umfasst alles, was Sie für eine Belegung des
Kaffeumsatzes benötigen. Bestehend aus den unten aufgeführten
Produkten.

The all-round set includes everything you need to boost your coffee
sales. Consisting of the below listed items.

Cromargan®, Glas, Porzellan /
stainless 18/10, glass, porcelain **06.2520.6040**

- | | |
|-------------------------|-------------------------|
| 12 Tablettts | 12 serving trays |
| 6 Gläser L (bedruckt) | 6 glasses L (printed) |
| 6 Gläser L (unbedruckt) | 6 glasses L (unprinted) |
| 12 Gläser S | 12 glasses S |
| 6 Porzellantassen M | 6 porcelain cups M |
| 6 Porzellantassen S | 6 porcelain cups S |
| 6 Ringe L | 6 rings L |
| 12 Ringe S | 12 rings S |
| 6 Griffe L | 6 handles L |
| 6 Griffe M | 6 handles M |
| 6 Griffe S | 6 handles S |
| 6 Muglöffel | 6 mug spoons |
| 6 Kaffeelöffel | 6 tea/coffee spoons |
| 6 Espressolöffel | 6 demi-tasse spoons |

Einzelartikel "KaffeeKultur"

single items "KaffeeKultur"

articles isolés "KaffeeKultur"

artículos diversos "KaffeeKultur"

singolo articolo "KaffeeKultur"

Cromargan®, Glas, Porzellan / stainless 18/10, glass, porcelain



①

① Tablett / serving tray

Größe	size		
cm	in.		
18,8 x 12 x 2	7 ¹ / ₂ x 4 ³ / ₄ x 3 ¹ / ₄		06.2500.6040



②



③



④

② Glas L bedruckt (VPE 6 Stk.) / glass L printed (unit 6 pcs.)

Höhe	height	Inhalt	cap.
cm	in.	Ltr.	oz.
11,6	4 ¹ / ₂	0,32	10,8

60.2505.9990

③ Glas L unbedruckt (VPE 6 Stk.) / glass L unprinted (unit 6 pcs.)

Höhe	height	Inhalt	cap.
cm	in.	Ltr.	oz.
11,6	4 ¹ / ₂	0,32	10,8

60.2505.9991

④ Glas S (VPE 6 Stk.) / glass S (unit 6 pcs.)

Höhe	height	Inhalt	cap.
cm	in.	Ltr.	oz.
7,4	3	0,1	3,4

60.2506.9990

⑤ Milchkaffeeschale (VPE 6 Stk.) / milk coffee pot (unit 6 pcs.)

Höhe	height	Inhalt	cap.
cm	in.	Ltr.	oz.
9,6	3 ³ / ₄	0,4	13,5

60.2526.9990

⑥ Porzellantasse M (VPE 6 Stk.) / porcelain cup M (unit 6 pcs.)

Höhe	height	Inhalt	cap.
cm	in.	Ltr.	oz.
9,6	3 ³ / ₄	0,25	8,5

60.2507.9990

⑦ Doppel-Espressotasse (VPE 6 Stk.) /

Espresso cup double (unit 6 pcs.)

Höhe	height	Inhalt	cap.	Ø	Ø
cm	in.	Ltr.	oz.	cm	in.
8,4	3 ¹ / ₄	0,13	4,4	6,2	2 ¹ / ₂

60.2541.9990

⑧ Porzellantasse S (VPE 6 Stk.) / porcelain cup S (unit 6 pcs.)

Höhe	height	Inhalt	cap.
cm	in.	Ltr.	oz.
7,4	3	0,1	3,4

60.2508.9990

⑨ Ring XL (VPE 6 Stk.) / ring XL (unit 6 pcs.)

passend auf Milchkaffeeschale / fitting on milk coffee pot

06.2525.6040

⑩ Ring L (VPE 6 Stk.) / ring L (unit 6 pcs.)

passend auf Glas L / fitting on glass L

06.2501.6040

⑪ Ring S (VPE 6 Stk.) / ring S (unit 6 pcs.)

passend auf Glas S, Tasse S, Doppel-Espresso-Tasse und Sahnekännchen von KaffeeKultur / fitting on glass S, cup S, Espresso double cup and creamer of CoffeeCulture

06.2502.6040

⑫ Griff L (VPE 6 Stk.) / handle L (unit 6 pcs.)

passend auf Glas L / fitting on glass L

06.2503.6040

⑬ Griff M (VPE 6 Stk.) / handle M (unit 6 pcs.)

passend auf Porzellantasse M / fitting on porcelain cup M

06.2504.6040

⑭ Griff S (VPE 6 Stk.) / handle S (unit 6 pcs.)

passend auf Glas S, Porzellantasse S, Doppel-Espressotasse und Sahnekännchen von KaffeeKultur / fitting on glass S, porcelain cup S, Espresso cup double and creamer of CoffeeCulture

06.2509.6040

⑮ Muglöffel (VPE 12 Stk.) / mug spoon (unit 12 pcs.)

Länge	length	
mm	in.	
157	6 ¹ / ₄	54.9903.6040

⑯ Kaffeelöffel (VPE 12 Stk.) / tea/coffee spoon (unit 12 pcs.)

Länge	length	
mm	in.	
136	5 ¹ / ₄	54.9902.6040

⑰ Espresso-/Mokkalöffel (VPE 12 Stk.) / demi-tasse spoon (unit 12 pcs.)

Länge	length	
mm	in.	
110	4 ¹ / ₄	54.9901.6040



⑤



⑥



⑦



⑧



⑨



⑩



⑪



⑫



⑬



⑭



⑮



⑯



⑰



Sahnekännchen (VPE 6 Stk.)

KaffeeKultur

creamer (unit 6 pcs.)
 crémier (UV 6 pc.)
 cremera (UV 6 p.)
 bricchetto per il latte (UV 6 p.)

kombinierbar mit Ring S, Griff S von KaffeeKultur und Deckel mit Ausschnitt /
 to be combined with ring S, handle S CoffeeCulture and lid with cut-out

Porzellan / porcelain

Höhe	height	Inhalt	cap.	
cm	in.	Ltr.	oz.	
7	2 ³ / ₄	0,1	3,4	55.0033.9990



Deckel mit Ausschnitt

lid with cut-out
 couvercle avec découpe
 tapa con recorte
 coperchio con punto aperto per cucchiaino

passend zu Glas S, Porzellantasse S, Sahnekännchen von KaffeeKultur und Porzellantasse S von CultureCup. /
 fitting for glass S, porcelain cup S, creamer of CoffeeCulture and porcelain cup S of CultureCup.

Cromargan® / stainless 18/10

Ø	Ø			
cm	in.			
6	2 ¹ / ₄			55.0031.6040



Sahne-/Zucker-Set

KaffeeKultur

sugar and milk set
 service pots à lait / sucriers
 juego azucarero / cremera
 set lattiera zuccheriera

bestehend aus: Tablett, Sahnekännchen und Zuckerbehälter. /
 consisting of: serving tray, creamer and sugar bowl.

Cromargan®, Porzellan / stainless 18/10, porcelain

Tablett / serving tray

Größe	size			
cm	in.			
18,8 x 12 x 2	7 ¹ / ₂ x 4 ³ / ₄ x 3 ³ / ₄			06.2500.6040

Sahnekännchen (VPE 6 Stk.) / creamer (unit 6 pcs.)

Höhe	height	Inhalt	cap.	
cm	in.	Ltr.	oz.	
7	2 ³ / ₄	0,1	3,4	55.0033.9990

Griff S (VPE 6 Stk.) / handle S (unit 6 pcs.) **06.2509.6040**

Porzellantasse S (VPE 6 Stk.) / porcelain cup S (unit 6 pcs.)

Höhe	height	Inhalt	cap.	
cm	in.	Ltr.	oz.	
7,4	3	0,1	3,4	60.2508.9990

Ring S (VPE 6 Stk.) / ring S (unit 6 pcs.) **06.2502.6040**

Deckel mit Ausschnitt / lid with cut-out **55.0031.6040**

Espresso-/Mokkalöffel (VPE 12 Stk.) /
 demi-tasse spoon (unit 12 pcs.) **54.9901.6040**

* Artikel einzeln bestellen / please order articles separately



Sahnekännchen, mit Deckel

KaffeeKultur

creamer, with lid
 crémier, avec couvercle
 cremera, con tapa
 bricchetto per il latte, con coperchio

Cromargan®, Porzellan / stainless 18/10, porcelain

Sahnekännchen (VPE 6 Stk.) / creamer (unit 6 pcs.)

Höhe	height	Inhalt	cap.	
cm	in.	Ltr.	oz.	
7	2 ³ / ₄	0,1	3,4	55.0033.9990

Griff S (VPE 6 Stk.) / handle S (unit 6 pcs.) **06.2509.6040**

Deckel mit Ausschnitt / lid with cut-out **55.0031.6040**

* Artikel einzeln bestellen / please order articles separately



Porzellanbehälter

KaffeeKultur

porcelain dish
 récipient en porcelaine
 recipiente de porcelana
 recipiente di porcellana

für Zucker, Marmelade, Senf u.a. /
 for sugar, jam, mustard ...

Cromargan®, Porzellan / stainless 18/10, porcelain

Porzellantasse S (VPE 6 Stk.) / porcelain cup S (unit 6 pcs.)

Höhe	height	Inhalt	cap.	
cm	in.	Ltr.	oz.	
7,4	3	0,1	3,4	60.2508.9990

Ring S (VPE 6 Stk.) / ring S (unit 6 pcs.) **06.2502.6040**

Deckel mit Ausschnitt / lid with cut-out **55.0031.6040**

Espresso-/Mokkalöffel (VPE 12 Stk.) /
 demi-tasse spoon (unit 12 pcs.) **54.9901.6040**

* Artikel einzeln bestellen / please order articles separately



Glasbehälter

KaffeeKultur

glass dish
 récipient en verre
 recipiente de cristal
 recipiente di vetro

für Zucker, Marmelade, Senf u.a. /
 for sugar, jam, mustard ...

Cromargan®, Glas / stainless 18/10, glass

Glas S (VPE 6 Stk.) / glass S (unit 6 pcs.)

Höhe	height	Inhalt	cap.	
cm	in.	Ltr.	oz.	
7,4	3	0,1	3,4	60.2506.9990

Ring S (VPE 6 Stk.) / ring S (unit 6 pcs.) **06.2502.6040**

Deckel mit Ausschnitt / lid with cut-out **55.0031.6040**

Espresso-/Mokkalöffel (VPE 12 Stk.) /
 demi-tasse spoon (unit 12 pcs.) **54.9901.6040**

* Artikel einzeln bestellen / please order articles separately



Latte Macchiato-Set

Latte Macchiato Set
latte-macchiato-set
juego latte macchiato
set latte-macchiato

12er Set bestehend aus:
12 x Glas, 12 x Löffel, 12 x Unterteller (Durchm. 12 cm) /
set of 12 pcs. consisting of:
12 x glass, 12 x spoon, 12 x underliner (dia. 4³/₄ in.)

Cromargan®, Glas / stainless 18/10, glass

Inhalt	cap.
Ltr.	oz.
0,3	10,5

06.3172.6040

Ersatzteil / spare part:

Eiskaffeeelöffel / iced tea spoon

12.9188.6040

6er Set Gläser / 6 glasses

19.9999.8667



Gläser-Set, Iced Coffee-Set

glass set, iced coffee set
set à glass
juego vasos
set da bicchieres

6er Set bestehend aus: 6 x Glas, 6 x Löffel, 6 x Tablett (18,8 x 12 cm) /
set of 6 pcs. consisting of: 6 x glass, 6 x spoon, 6 x serving tray (18,8 x
12 cm / 7 1/2 x 4 3/4 in.)

Cromargan®, Glas / stainless 18/10, glass

55.0090.6040

Ersatzteil / spare part:

Ersatzglas, (6 Stk.) / spare glasses, (6 pcs.)

55.0089.9990

Inhalt	cap.
Ltr.	oz.
0,3	10,5

0,3 10,5

Tablett / serving tray

06.2500.6040

Mugelöffel (VPE 12 Stk.) / mug spoon (unit 12 pcs.)

54.9903.6040



Teeglas

PURE

tea glass
verre à thé
vaso té
bicchiere da tè

Cromargan®, Glas / stainless 18/10, glass

Höhe	height	Inhalt	cap.	Ø	Ø
cm	in.	Ltr.	oz.	cm	in.
9	3 1/2	0,2	6,76	6,5	2 1/2

06.3565.6040

Ersatzteil / spare part:

Glaseinsatz / glass insert

60.3147.9990



Teasieb-Behälter (VPE 6 Stk.)

tea strainer holder (unit 6 pcs.)
 soucoupe pour passoire à thé (UV 6 pc.)
 recipiente colador té (UV 6 p.)
 contenitore per colino tè (UV 6 p.)

für Teesieb-Einsatz 06.3428.6030; kombinierbar mit Ring S von KaffeeKultur /
 fitting for tea strainer insert 06.3428.6030; to be combined with ring S CoffeeCulture

Porzellan, weiß / porcelain, white

Höhe	height	Inhalt	cap.	Ø	Ø	
cm	in.	Ltr.	oz.	cm	in.	
8,4	3 ¹ / ₄	0,13	4,4	6,2	2 ¹ / ₂	60.2541.9990

Zubehör / accessory:

Ring S (VPE 6 Stk.) / ring S (unit 6 pcs.) **06.2502.6040**



Teesieb-Einsatz

tea strainer insert
 passoire à thé
 interior colador té
 colino per tè

passend in alle WMF-Teekannen /
 fitting in all WMF tea pots

Cromargan® / stainless 18/10

Höhe	height	Ø	Ø	
cm	in.	cm	in.	
7	2 ³ / ₄	5	2	06.3428.6030



Teesieb, mit Abtropfschale

tea strainer, with bowl
 passoire, avec réceptacle à thé
 recipiente colador, de té con bandejita escurridora
 colino per tè con vaschetta raccogliocce

Höhe	height	Größe	size	Cromargan®	versilbert
cm	in.	cm	in.	stainless 18/10	silverplated
3	1 ¹ / ₄	12 x 9,5	4 ³ / ₄ x 3 ³ / ₄	06.3327.6040	19.3327.6440



Zitronenpresse, 6er Set

lemon/orange squeezer, set of 6
 presse-citron, en 6 parties
 exprimidor para limones, 6 piezas
 spremilimone, a 6 vaschette

Cromargan® mattiert / stainless 18/10, satin finished **06.8221.6030**



Kaffeekanne

URBAN

coffee pot
cafetière
cafetera
caffettiera

Höhe cm	height in.	Inhalt Ltr.	cap. oz.	Cromargan® stainless 18/10	versilbert silverplated
13,5	5 ¹ / ₄	0,3	10,14	06.3342.6041	19.3342.6441
15,5	6	0,5	16,9	06.3344.6041	19.3344.6441
20	7 ³ / ₄	1	33,8	06.3346.6041	19.3346.6441



Teekanne

URBAN

tea pot
théière
tetera
teiera

Höhe cm	height in.	Inhalt Ltr.	cap. oz.	Cromargan® stainless 18/10	versilbert silverplated
12	4 ³ / ₄	0,3	10,14	06.3350.6041	19.3350.6441
14	5 ¹ / ₂	0,5	16,9	06.3351.6041	19.3351.6441



Milchkanne

URBAN

milk jug
pot à lait
lechera
lattiera

Höhe cm	height in.	Inhalt Ltr.	cap. oz.	Cromargan® stainless 18/10	versilbert silverplated
9,6	3 ³ / ₄	0,2	6,76	06.3360.6041	19.3360.6441
11,5	4 ¹ / ₂	0,3	10,14	06.3361.6041	19.3361.6441



Zuckerdose

URBAN

sugar basin
sucrier
azucarero
zuccheriera

Höhe cm	height in.	Inhalt Ltr.	cap. oz.	Cromargan® stainless 18/10	versilbert silverplated
7,4	3	0,25	8,45	06.3370.6041	19.3370.6441



Kaffeekanne

CLASSIC

coffee pot
cafetière
cafetera
caffettiera

Höhe cm	height in.	Inhalt Ltr.	cap. oz.	Cromargan® stainless 18/10	versilbert silverplated
13,5	5 ¹ / ₄	0,3	11	06.3501.6040	19.3501.6440
17	6 ³ / ₄	0,6	21	06.3502.6040	19.3502.6440
22	8 ³ / ₄	1,5	53	06.3504.6040	19.3504.6440
25,5	10	2	70	06.3509.6040	



Teekanne

CLASSIC

tea pot
théière
tetera
teiera

Höhe cm	height in.	Inhalt Ltr.	cap. oz.	Cromargan® stainless 18/10	versilbert silverplated
11	4 ¹ / ₄	0,3	11	06.3506.6040	19.3506.6440
14,5	5 ³ / ₄	0,55	19	06.3507.6040	19.3507.6440
17,5	7	1,25	44	06.3508.6040	19.3508.6440



Milchkanne

CLASSIC

milk jug
pot à lait
lechera
lattiera

Höhe cm	height in.	Inhalt Ltr.	cap. oz.	Cromargan® stainless 18/10	versilbert silverplated
8,5	3 ¹ / ₂	0,15	5	06.3512.6040	19.3512.6440
11	4 ¹ / ₄	0,3	11	06.3513.6040	19.3513.6440
13,5	5 ¹ / ₂	0,6	21	06.3514.6040	19.3514.6440



Zuckerdose

CLASSIC

sugar basin
sucrier
azucarero
zuccheriera

Höhe cm	height in.	Inhalt Ltr.	cap. oz.	Cromargan® stainless 18/10	versilbert silverplated
7	2 ³ / ₄	0,25	8,8	06.3519.6040	19.3519.6440



**Zuckerdose, mit Deckel
CLASSIC**

sugar basin, with cover
sucrier, avec couvercle
azucarero, con tapa
zuccheriera, con coperchio

Höhe cm	height in.	Inhalt Ltr.	cap. oz.	Cromargan® stainless 18/10	versilbert silverplated
9,5	3 ³ / ₄	0,15	5,3	06.3520.6040	19.3520.6440
12	4 ³ / ₄	0,25	8,8	06.3521.6040	19.3521.6440



**Kaffeekanne
PURE**

coffee pot
cafétière
cafetera
caffettiera

stapelbar /
stackable

Cromargan®, teilmattiert /
stainless 18/10, partly satin finished

Höhe cm	height in.	Inhalt Ltr.	cap. oz.	
11,5	4 ¹ / ₂	0,3	11	06.3801.6040
14	5 ¹ / ₂	0,6	21	06.3808.6040
20	8	1,9	66,5	06.3809.6040



**Teekanne
PURE**

tea pot
théière
tetera
teiera

stapelbar /
stackable

Cromargan®, teilmattiert /
stainless 18/10, partly satin finished

Höhe cm	height in.	Inhalt Ltr.	cap. oz.	
9,5	3 ³ / ₄	0,3	11	06.3802.6040

Sahnegießer

PURE

creamer
crémier
cremera
cremiera

Cromargan®, teilmattiert /
stainless 18/10, partly satin finished



Höhe	height	Inhalt	cap.
cm	in.	Ltr.	oz.
5	2	0,03	1,1

06.3807.6040

Zuckerdosierer

sugar dispenser
saupoudreuse à sucre
dosificador azúcar
versazucchero

Cromargan®, Glas / stainless 18/10, glass



Höhe	height	Inhalt	cap.
cm	in.	Ltr.	oz.
15,5	6	0,24	8,4

06.3661.6040

Ersatzteil / spare part:
Ersatzglas / spare glass

60.8294.9990

Honig-/Sahnspender

honey/cream dispenser
distributeur à miel / crème
dispensador miel / nata
versamiele / versalette



Cromargan®, Glas / stainless 18/10, glass

Höhe	height	Inhalt	cap.
cm	in.	Ltr.	oz.
15,5	6	0,24	8,4

06.3664.6040

Ersatzteil / spare part:
Ersatzglas / spare glass

60.8294.9990



**Zuckergestell, 4tlg.
CLASSIC**

sugar server, set of 4
service à sucre, en 4 parties
servicio de azúcar, 4 piezas
zuccheriera, a 4 vaschette

Höhe	height
cm	in.
21	8 1/4

Cromargan®	versilbert
stainless 18/10	silverplated
06.3186.6040	19.3186.6440

Ersatzteil / spare part:
Porzellaneinsatz / porcelain insert

60.3099.9990



Serviertablett für Zucker

serving tray for sugar
plateau de service pour sucre
bandeja con azucareros
vassoio per zucchero

Tablett, oval / serving tray, oval

Größe	size
cm	in.
22 x 15,5	8 3/4 x 6

Cromargan®	versilbert
stainless 18/10	silverplated
06.7540.6040	19.7540.6440

Zuckerdose / sugar bowl

Inhalt	cap.	Ø	Ø	Cromargan®
Ltr.	oz.	cm	in.	stainless 18/10
0,1	3,5	6	2 1/4	06.3752.6040

* Artikel einzeln bestellen / please order articles separately



**Milch-Zucker-Set
CLASSIC**

sugar and creamer set
service pots à lait / sucriers
juego azucarero / cremera
set lattiera zuccheriera

Cromargan® / stainless 18/10

Höhe	height
cm	in.
18,5	7 1/4

06.3185.6040

Ersatzteil / spare part:

Milchkanne / milk jug

06.3415.6040

Höhe	height	Inhalt	cap.
cm	in.	Ltr.	oz.
8	3 1/4	0,15	5,3

Zuckerdose / sugar bowl

06.3752.6040

Inhalt	cap.	Ø	Ø
Ltr.	oz.	cm	in.
0,1	3,5	6	2 1/4



Sahne-Zucker-Set PURE

sugar and creamer set
service pots à lait / sucriers
juego azucarero / cremera
set lattiera zuccheriera

bestehend aus: Gestell, Sahnekännchen, Zuckerdose, Löffel /
consisting of: stand, cream dispenser, sugar dispenser, spoon

Cromargan®, teilmattiert /
stainless 18/10, partly satin finished

Höhe cm	height in.	Inhalt Ltr.	cap. oz.	
18	7	0,2	7	06.3804.6040

Ersatzteil / spare part:

Gestell / stand	06.3804.6045
Milchkännchen / creamer	06.3806.6040
Zuckerdose / sugar basin	06.3805.6040



Sahne-Zucker-Set PURE

sugar and creamer set
service pots à lait / sucriers
juego azucarero / cremera
set lattiera zuccheriera

bestehend aus: Gestell, Sahnekännchen, Zuckerstangengefäß /
consisting of: stand, cream dispenser, sugar pack holder

Cromargan®, teilmattiert /
stainless 18/10, partly satin finished

Höhe cm	height in.	Inhalt Ltr.	cap. oz.	
18	7	0,2	7	06.3803.6040

Ersatzteil / spare part:

Gestell / stand	06.3804.6045
Milchkännchen / creamer	06.3806.6040
Zuckerstangengefäß / sugar pack holder	06.7120.6040



Zuckergestell, 4tlg. PURE

sugar set, 4 pcs.
service à sucriers, 4 parties
juego azucarero, 4 piezas
set zuccheriera, a 4vaschette

bestehend aus: Gestell, 4x Zuckerbehälter /
consisting of: stand, 4 sugar bowls

Cromargan® / stainless 18/10

Höhe cm	height in.	Ø cm	Ø in.	
16,1	6 ¹ / ₂	14	5 ¹ / ₂	06.2339.6040

Ersatzteil / spare part:

Gestell nieder / stand low 06.2340.6045

Höhe cm	height in.	Ø cm	Ø in.
16	6 ¹ / ₄	14	5 ¹ / ₂

Porzellaninsert / porcelain insert 60.3099.9990



Sahne-Zucker-Set

PURE

sugar and milk set
 service pots à lait / sucriers
 juego azucarero / cremera
 set lattiera zuccheriera

bestehend aus Gestell, 2x Zuckerbehälter Glas und Sahnekännchen Porzellan /

consisting of: stand, 2x sugar bowl glass and creamer porcelain

Cromargan®, Glas, Porzellan / stainless 18/10, glass, porcelain

Gestell nieder / stand low

Höhe cm	height in.	Ø cm	Ø in.	
16	6 1/4	14	5 1/2	06.2340.6045

Glas S (VPE 6 Stk.) / glass S (unit 6 pcs.)

Höhe cm	height in.	Inhalt Ltr.	cap. oz.	
7,4	3	0,1	3,4	60.2506.9990

Ring S (VPE 6 Stk.) / ring S (unit 6 pcs.)

06.2502.6040

Deckel mit Ausschnitt / lid with cut-out

55.0031.6040

Sahnekännchen (VPE 6 Stk.) / creamer (unit 6 pcs.)

Höhe cm	height in.	Inhalt Ltr.	cap. oz.	
7	2 3/4	0,1	3,4	55.0033.9990

Griff S (VPE 6 Stk.) / handle S (unit 6 pcs.)

06.2509.6040

Espresso-/Mokkalöffel (VPE 12 Stk.) /
 demi-tasse spoon (unit 12 pcs.)

54.9901.6040

* Artikel einzeln bestellen / please order articles separately



Milch-Zucker-Set, 3tlg.

PURE

sugar and milk set, set of 3
 service pots à lait / sucriers, en 3 parties
 juego azucarero / cremera, 3 piezas
 set lattiera zuccheriera, a 3 vaschette

bestehend aus: Gestell, 2x Zuckerbehälter, 1 Sahnekännchen /
 consisting of: stand, 2x sugar bowl, 1 milk pot

Cromargan® / stainless 18/10

Höhe cm	height in.	Ø cm	Ø in.	
16,1	6 1/2	14	5 1/2	06.2340.6040

Ersatzteil / spare part:

Zuckerdose, mit Deckel / sugar basin, with cover

06.2342.6040

Höhe cm	height in.	Inhalt Ltr.	cap. oz.	Ø cm	Ø in.
5,2	2	0,1	3,5	6	2 1/4

Gestell nieder / stand low

06.2340.6045

Höhe cm	height in.	Ø cm	Ø in.
16	6 1/4	14	5 1/2

Milchkännchen / creamer

06.3806.6040

Höhe cm	height in.	Inhalt Ltr.	cap. oz.
8,5	3 1/4	0,2	7

Milch-Zucker-Set

PURE EXCLUSIV

sugar and milk set
service pots à lait / sucriers
juego azucarero / cremera
set lattiera zuccheriera

in 2 Holzvarianten. Mit 3 Einsätzen für wahlweise Gläser S, Tassen S (o. Abb.) oder Sahnekännchen KAFFEEKULTUR und Tassen S von CULTURECUP (o. Abb.). Nicht spülmaschinengeeignet! /
in 2 wood versions. With 3 inserts alternatively for glasses S, cups S (w/o pic.) or creamer of CoffeeCulture and cups S of CultureCup (w/o pic.). Not dishwasher-safe!

Cromargan®, Holz dunkel gebeizt, Holz lackiert /
stainless 18/10, wood dark stained, wood lacquered



Menage klein dunkel / stand small dark

Größe	size
cm	in.
20,5 x 6,2 x 3,7	8 x 2 ¹ / ₂ x 1 ¹ / ₂

55.0039.6040

Menage klein natur / stand small nature

Größe	size
cm	in.
20,5 x 6,2 x 3,7	8 x 2 ¹ / ₂ x 1 ¹ / ₂

55.0039.6140



Glas S (VPE 6 Stk.) / glass S (unit 6 pcs.)

Höhe	height	Inhalt	cap.
cm	in.	Ltr.	oz.
7,4	3	0,1	3,4

60.2506.9990

Sahnekännchen (VPE 6 Stk.) / creamer (unit 6 pcs.)

Höhe	height	Inhalt	cap.
cm	in.	Ltr.	oz.
7	2 ³ / ₄	0,1	3,4

55.0033.9990

Deckel mit Ausschnitt / lid with cut-out

55.0031.6040

Espresso-/Mokkalöffel (VPE 12 Stk.) /
demi-tasse spoon (unit 12 pcs.)

54.9901.6040

* Artikel einzeln bestellen / please order articles separately



**Milch-Zucker-Set, 4tlg.
PURE EXCLUSIV**

sugar and milk set, set of 4
service pots à lait / sucriers, en 4 parties
juego azucarero / cremera, 4 piezas
set lattiera zuccheriera, a 4 vaschette

in 2 Holzvarianten. Mit 4 Einsätzen für Gläser S oder Tassen S (o.Abb.) von KAFFEEKULTUR, Sahnekännchen und Zuckerstangengefäß von PURE oder Tassen S von CULTURECUP (o.Abb.). Nicht spülmaschinengeeignet! / in 2 wood versions. With 4 inserts for glasses S or cups S (w/o pic.) of CoffeeCulture or creamer and sugar pack holder of PURE or cups S of CultureCup (w/o pic.). Not dishwasher-safe!

Cromargan®, Holz dunkel gebeizt, Holz lackiert / stainless 18/10, wood dark stained, wood lacquered

Menage groß dunkel / stand large dark

Größe	size	
cm	in.	
14,5 x 14,5 x 25,4	5 ³ / ₄ x 5 ³ / ₄ x 10	55.0034.6040

Menage groß natur / stand large nature

Größe	size	
cm	in.	
14,5 x 14,5 x 25,4	5 ³ / ₄ x 5 ³ / ₄ x 10	55.0034.6140

Glas S (VPE 6 Stk.) / glass S (unit 6 pcs.)

Höhe	height	Inhalt	cap.
cm	in.	Ltr.	oz.
7,4	3	0,1	3,4
			60.2506.9990

Milchkännchen / creamer

Höhe	height	Inhalt	cap.
cm	in.	Ltr.	oz.
8,5	3 ¹ / ₄	0,2	7
			06.3806.6040

Zuckerstangengefäß / sugar pack holder

Höhe	height	Ø	Ø
cm	in.	cm	in.
8,5	3 ¹ / ₄	6	2 ¹ / ₄
			06.7120.6040

Deckel mit Ausschnitt / lid with cut-out

55.0031.6040

Espresso-/Mokkalöffel (VPE 12 Stk.) /
demi-tasse spoon (unit 12 pcs.)

54.9901.6040

* Artikel einzeln bestellen / please order articles separately



Milch-Zucker-Set, 4tlg.

PURE EXCLUSIV

sugar and milk set, set of 4
 service pots à lait / sucriers, en 4 parties
 juego azucarero / cremera, 4 piezas
 set lattiera zuccheriera, a 4 vaschette

in 2 Holzvarianten. Mit 4 Einsätzen für Gläser S oder Tassen S (o.Abb.) von KAFFEEKULTUR, Sahnekännchen und Zuckerdose von PURE oder Tassen S von CULTURECUP (o.Abb.). Nicht spülmaschinengeeignet! / in 2 wood versions. With 4 inserts for glasses S or cups S (w/o pic.) of CoffeeCulture or creamer and sugar basin of PURE or cups S of CultureCup (w/o pic.). Not dishwasher-safe!

Cromargan®, Holz dunkel gebeizt, Holz lackiert / stainless 18/10, wood dark stained, wood lacquered

Menage groß dunkel / stand large dark

Größe	size	
cm	in.	
14,5 x 14,5 x 25,4	5 ³ / ₄ x 5 ³ / ₄ x 10	55.0034.6040

Menage groß natur / stand large nature

Größe	size	
cm	in.	
14,5 x 14,5 x 25,4	5 ³ / ₄ x 5 ³ / ₄ x 10	55.0034.6140

Glas S (VPE 6 Stk.) / glass S (unit 6 pcs.)

Höhe	height	Inhalt	cap.	
cm	in.	Ltr.	oz.	
7,4	3	0,1	3,4	60.2506.9990

Zuckerdose, mit Deckel / sugar basin, with cover

Höhe	height	Inhalt	cap.	Ø	Ø	
cm	in.	Ltr.	oz.	cm	in.	
5,2	2	0,1	3,5	6	2 ¹ / ₄	06.2342.6040

Milchkännchen / creamer

Höhe	height	Inhalt	cap.	
cm	in.	Ltr.	oz.	
8,5	3 ³ / ₄	0,2	7	06.3806.6040

Deckel mit Ausschnitt / lid with cut-out

55.0031.6040

Espresso-/Mokkalöffel (VPE 12 Stk.) / demi-tasse spoon (unit 12 pcs.)

54.9901.6040

* Artikel einzeln bestellen / please order articles separately



Zuckerdose

PURE

sugar basin
sucrier
azucarero
zuccheriera

Cromargan®, teilmattiert /
stainless 18/10, partly satin finished

Höhe	height	Inhalt	cap.
cm	in.	Ltr.	oz.
8,5	3 1/4	0,2	7

06.3805.6040



Zuckerdose, mit Deckel

PURE

sugar basin, with cover
sucrier, avec couvercle
azucarero, con tapa
zuccheriera, con coperchio

Cromargan®, teilmattiert /
stainless 18/10, partly satin finished

Höhe	height	Inhalt	cap.	Ø	Ø
cm	in.	Ltr.	oz.	cm	in.
5,2	2	0,1	3,5	6	2 1/4

06.2342.6040



Zuckerstangengefäß

PURE

sugar pack holder
pots à sucriers
azucarero para azúcar en cañas
set zuccheriera

stapelbar /
stackable

Cromargan®, teilmattiert /
stainless 18/10, partly satin finished

Höhe	height	Ø	Ø
cm	in.	cm	in.
8,5	3 1/4	6	2 1/4

06.7120.6040



Milchkännchen

PURE

creamer
pots à lait
cremera
lattiera

Cromargan®, teilmattiert /
stainless 18/10, partly satin finished

Höhe	height	Inhalt	cap.
cm	in.	Ltr.	oz.
8,5	3 1/4	0,2	7

06.3806.6040



**Zahnstocher- und Süßstoffbehälter
PURE**

toothpick- and sweetener box-holder
porte-cure-dents et récipient pour sucrées
palillero y dispensador de edulcorante
porta stuzzicadenti e contenitore per dolcificante

zum Einhängen in alle WMF PURE-Gestelle mit Bügelgriff.
Laser-Gravur der Tischnummer nach Wunsch - Preis auf Anfrage /
fitting in all racks of WMF PURE sets. Engraving of the table No. on
request - please ask for respective costs

Cromargan® / stainless 18/10

Höhe	height
cm	in.
4	1½

06.1905.6044



**Kaffeetablett
PURE**

serving tray
plateau de service
bandeja
vassoio

stapelbar, oval /
stackable, oval



Cromargan® / stainless 18/10

Größe	size
cm	in.
27 x 17	10½ x 6¾

06.7550.6040



**Porzellanschale, 3-geteilt
PURE**

porcelain bowl 3-section
coupe en porcelaine 3 parties
cuenco de porcelana 3 divisiones
vassoietto tripartito portazzucchero

mit 2 Unterteilungen für Tee, Zucker oder Antipasti /
with 2 partitions for tea, sugar or Antipasti



Porzellan weiß / porcelain white

Größe	size
cm	in.
21 x 8,7 x 3,25	8¼ x 3½ x 1¼

60.3538.9990

Zubehör / accessory:

Tablett, oval / serving tray, oval

Größe	size
cm	in.
24,5 x 12	9½ x 4¾

06.7551.6040



**Punchbowl
CLASSIC**

punch bowl
bol à punch
ponchera
bowl per punch

Cromargan® / stainless 18/10

Höhe	height	Inhalt	cap.	Ø	Ø	
cm	in.	Ltr.	oz.	cm	in.	
29	11 1/2	10	350	38,5	15 1/4	06.0446.6040

versilbert / silverplated

Höhe	height	Inhalt	cap.	Ø	Ø	
cm	in.	Ltr.	oz.	cm	in.	
29	11 1/2	10	350	38,5	15 1/4	19.0446.6440



**Punchbowl
PURE**

punch bowl
bol à punch
ponchera
bowl per punch

Cromargan® / stainless 18/10

Höhe	height	Ø	Ø	
cm	in.	cm	in.	
27	10 3/4	38	15	06.0471.6040



**Punchbowl
NEUTRAL**

punch bowl
bol à punch
ponchera
bowl per punch

Cromargan® / stainless 18/10

Höhe	height	Inhalt	cap.	Ø	Ø	
cm	in.	Ltr.	oz.	cm	in.	
29	11 1/2	10	350	38,5	15 1/4	06.0449.6040



Getränkekühler

DIVA

beverage cooler
seau à boisson
cubo bebida
rinfresca bevanda

doppelwandig und stapelbar. Kann verwendet werden mit Kühlelement 55.0125.9990, für 3 Wasser-, Saft-, Milchkaraffen 06.1770.6040, 3 Getränkeflaschen (Bsp. Wasser, Wein, etc.) mit max. 10 cm Flaschendurchmesser, 6 Getränkeflaschen (Bsp. Wasser, Saft, Bier etc.) mit max. 7 cm Flaschendurchmesser /
double wall and stackable. Can be used with cooling element 55.0125.9990, for 3 water/juice/milk decanter 06.1770.6040, 3 beverage bottles (e.g. water, wine, etc.) with max. 4 in. bottle diameter, 6 beverage bottles (e.g. water, juice, beer, etc.) with max. 2 3/4 in. bottle diameter



Cromargan® / stainless 18/10

Größe cm	size in.	Inhalt Ltr.	cap. oz.	
27,5 x 26,2 x 17	10 ³ / ₄ x 10 ¹ / ₄ x 6 ³ / ₄	7,3	257	55.0124.6040

Das passende Kühlelement DIVA 55.0125.9990 finden Sie auf Seite 241.
The matching cooling element DIVA 55.0125.9990 can be found on page 241.

Wein-/Sektühler

CLASSIC

wine / champagne cooler
seau à vin / champagne
cubo vino / champán
rinfrescavino / spumante



oval, für 2 Flaschen /
oval, for 2 bottles

Höhe cm	height in.	Inhalt Ltr.	cap. oz.	Cromargan® stainless 18/10	versilbert silverplated
20,6	8	7,3	257	06.8191.6040	19.8191.6440

Wein-/Sektühler

CLASSIC

wine / champagne cooler
seau à vin / champagne
cubo vino / champán
rinfrescavino / spumante



passend in Weinkühlerständer mit Durchmesser mind. 15 cm /
fitting in stand for wine/champagne cooler with dia. 15 cm minimum

rund /
round

Höhe cm	height in.	Inhalt Ltr.	cap. oz.	Cromargan® stainless 18/10	versilbert silverplated
20,8	8 ¹ / ₄	4,3	151	06.8190.6040	19.8190.6440



**Wein-/Sektküher
CLASSIC**

wine / champagne cooler
seau à vin / champagne
cubo vino / champán
rinfrescavino / spumante

rund, für 2 Flaschen. Passend in Weinkühlerständer mit Durchm. mind. 20 cm /
round, for 2 bottles. Fitting in stand for wine/champagne with dia. 20 cm minimum

Cromargan® / stainless 18/10

Höhe cm	height in.	Inhalt Ltr.	cap. oz.
23,5	9 ¹ / ₄	8	281

06.8051.6040



**Wein-/Sektküher
PURE**

wine / champagne cooler
seau à vin / champagne
cubo vino / champán
rinfrescavino / spumante

rund. Passend in Weinkühlerständer mit Durchm. mind. 16 cm /
round. Fitting in stand for wine/champagne with dia. 16 cm minimum

Cromargan® / stainless 18/10

Höhe cm	height in.	Inhalt Ltr.	cap. oz.	Ø cm	Ø in.
22	8 ³ / ₄	4,7	165	19	7 ¹ / ₂

06.0469.6040



**Weinkühler
URBAN**

wine / champagne cooler
seau à vin / champagne
cubo vino / champán
rinfrescavino / spumante

doppelwandig. Passend in Weinkühlerständer mit Durchm. mind. 16 cm. /
double wall. Fitting in stand for wine/champagne with dia. 16 cm minimum.

Cromargan® / stainless 18/10

Höhe cm	height in.	Inhalt Ltr.	cap. oz.	Ø cm	Ø in.
24	9 ¹ / ₂	3,2	113	16	6 ¹ / ₄

55.0064.6040



**Wein-/Sektküher
NEUTRAL**

wine / champagne cooler
seau à vin / champagne
cubo vino / champán
rinfrescavino / spumante

rund. Passend in Weinkühlerständer mit Durchm. mind. 16 cm /
round. Fitting in stand for wine/champagne with dia. 16 cm minimum

Cromargan® / stainless 18/10

Höhe cm	height in.	Inhalt Ltr.	cap. oz.
20,8	8 ¹ / ₄	4,3	151

06.8019.6040



Weinkühler

wine cooler
seau à vin
cubo vino
rinfrescavino

doppelwandig. Passend in Weinkühlerständer mit Durchm. mind. 12,5 cm /

double wall. Fitting in stand for wine/champagne with dia. 12,5 cm minimum

Cromargan® / stainless 18/10

Höhe cm	height in.	Inhalt Ltr.	cap. oz.	Ø cm	Ø in.	
19,5	7 ³ / ₄	1,6	56	12	4 ³ / ₄	06.8239.6040



Getränkekühlerständer

DIVA

stand for beverage cooler
support pour seau à boisson

Höhe cm	height in.	Ø Schale cm	dish Ø in.	
59,5	23 ¹ / ₂	30	11 ³ / ₄	55.0126.6040

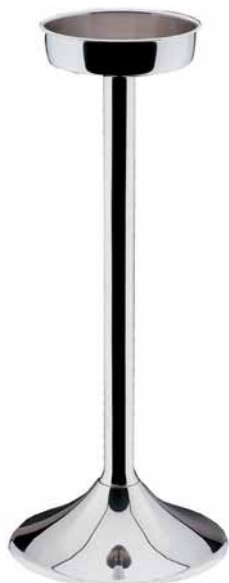

Weinkühlerständer

NEUTRAL

stand for wine/champagne cooler
support pour seau à champagne
portacubos champán
colonna per secchio spumante

rund /
round

Höhe cm	height in.	Ø Schale cm	dish Ø in.	Cromargan® stainless 18/10	versilbert silverplated
60	23 ¹ / ₂	16	6 ¹ / ₄	06.8337.6040	19.8337.6440

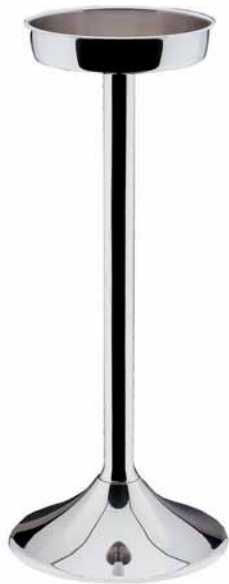

**Weinkühlerständer
NEUTRAL**

stand for wine/champagne cooler
support pourseau à champagne
portacubos champán
colonna per secchio spumante

rund /
round

Cromargan® / stainless 18/10

Höhe	height	Ø Schale	dish Ø
cm	in.	cm	in.
60	23 1/2	20	8

06.8452.6040

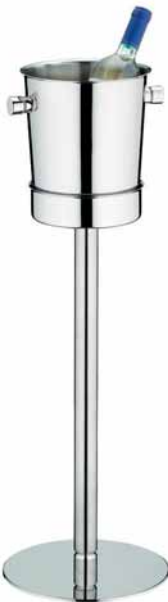

**Weinkühlerständer
PURE**

stand for wine/champagne cooler
support pourseau à champagne
portacubos champán
colonna per secchio spumante

rund /
round

Cromargan® / stainless 18/10

Höhe	height	Ø	Ø	Ø Schale	dish Ø
cm	in.	cm	in.	cm	in.
68,8	27	25	9 3/4	16	6 1/4

06.0468.6040



**Flaschenteller
CLASSIC**

coaster for bottles
dessous de bouteille
portabotella
sottobottiglia

Ø Schale	dish Ø
cm	in.
10,5	4 1/4

Cromargan® versilbert
stainless 18/10 silverplated
06.2177.6040 19.2177.6440



Rotweinwiege

red wine cradle
 porte-bouteille
 portabotellas
 versavino

für Flasche 0,75 Ltr. /
 for bottle 26,3 oz.

verchromt / chromeplated

06.8045.5080



Weinkorb

wine-basket
 panier à vin
 cesta vino
 cestino portavino

versilbert / silverplated

Höhe	height	Größe	size
cm	in.	cm	in.
17,5	7	23,5 x 10	9 1/4 x 4

19.2379.6440



**Sauciere
NEUTRAL**

gravy boat
saucière
salsera
salsiere

auf Fuß /
footed

Cromargan® / stainless 18/10

Inhalt	cap.
Ltr.	oz.
0,15	5,3
0,3	10,5
0,5	17,5

06.6244.6040
06.6245.6040
06.6246.6040



**Sauciere
PURE**

gravy boat
saucière
salsera
salsiere

auf Fuß, stapelbar /
footed, stackable

Cromargan® teilmattiert / stainless 18/10 partly satin finished

Inhalt	cap.
Ltr.	oz.
0,2	7
0,5	17,5

06.0473.6040
06.0474.6040



**Légumier
CLASSIC**

vegetable dish and cover
légumier et couvercle
legumbrera con tapa
legumiera con coperchio

Cromargan® / stainless 18/10

Inhalt	cap.	Ø	Ø	Unterteil	Deckel
Ltr.	oz.	cm	in.	base	cover
0,35	12,3	14	5½	06.2701.6041	
		14	5½		06.2701.6042

06.2701.6041
06.2701.6042

versilbert / silverplated

Inhalt	cap.	Ø	Ø	Unterteil	Deckel
Ltr.	oz.	cm	in.	base	cover
0,35	12,3	14	5½	19.2701.6441	
		14	5½		19.2701.6442

19.2701.6441
19.2701.6442



Légumier NEUTRAL

vegetable dish and cover
légumier et couvercle
legumbreira con tapa
legumiera con coperchio

Cromargan® / stainless 18/10

Inhalt	cap.	Ø	Ø	Unterteil	Deckel
Ltr.	oz.	cm	in.	base	cover
0,35	12,3	14	5½	06.2786.6041	06.2786.6042
0,6	21	16	6¼	06.2787.6041	06.2787.6042
		16	6¼		



Universalschale PURE

universal dish
coupe universelle
recipiente universal
ciotola universale

stapelbar /
stackable



Cromargan® teilmattiert / stainless 18/10 partly satin finished

Höhe	height	Ø Schale	dish Ø	
cm	in.	cm	in.	
5,5	2¼	12	4¾	06.1799.6040

Universalschale

finger bowl
coupe universelle
recipiente universal
ciotola universale

Cromargan® / stainless 18/10

Inhalt	cap.	Ø Schale	dish Ø	
Ltr.	oz.	cm	in.	
0,2	7	12	4¾	06.1849.6040



Butterkühler CLASSIC

butter cooler
refraîchisseur à beurre
enfriador para mantequilla
rinfresca-burro



Höhe	height	Ø	Ø	Cromargan®	versilbert
cm	in.	cm	in.	stainless 18/10	silverplated
8	3¼	5,5	2¼	06.1090.6040	19.1090.6440

Ersatzteil / spare part:
Porzellanunterteil / porcelain base

60.3038.0690



**Butterkühler
CLASSIC**

butter cooler
refraîchisseur à beurre
enfriador para mantequilla
rinfresca-burro

mit Unterteller /
with underliner

Cromargan® / stainless 18/10

Höhe cm	height in.	Ø cm	Ø in.
6	2 ¹ / ₄	15,5	6

06.1087.6040

Ersatzteil / spare part:

Unterteil / base	06.1085.6041
Einsatzsieb / sieve	06.1085.6044
Cloche / cover	06.1087.6042
Unterteller / underliner	06.1087.6043



**Butterkühler
NEUTRAL**

butter cooler
refraîchisseur à beurre
enfriador para mantequilla
rinfresca-burro

mit Unterteller /
with underliner

Cromargan® / stainless 18/10

Höhe cm	height in.	Ø cm	Ø in.
6,5	2 ¹ / ₂	14,5	5 ³ / ₄

06.1089.6040

Ersatzteil / spare part:

Einsatzsieb / sieve	06.1089.6044
Unterteller / underliner	06.1089.6043



**Butterkühler
CLASSIC**

butter cooler
refraîchisseur à beurre
enfriador para mantequilla
rinfresca-burro

	Ø cm	Ø in.	Cromargan® stainless 18/10	versilbert silverplated
Unterteil / base	12	4 ³ / ₄	06.3847.6041	19.3847.6441
Einsatz / sieve			06.1082.6044	19.1082.6444



Butterkühler

butter cooler
refraîchisseur à beurre
enfriador para mantequilla
rinfresca-burro

Cromargan® / stainless 18/10

	Inhalt Ltr.	cap. oz.	Ø Schale cm	dish Ø in.
Universalschale / finger bowl	0,2	7	12	4 ³ / ₄
Einsatz / sieve				

06.1849.6040

06.1082.6044



Dessertgestell PURE EXCLUSIV

dessert stand
présentoir à gâteau
soporte plato postre
porta piattini per dessert

in 2 Holzvarianten. Mit 3 Einsätzen für wahlweise Gläser S, Tassen S oder Sahnekännchen (o. Abb.) von KaffeeKultur und Tassen S von CultureCup (o. Abb.). Nicht spülmaschinengeeignet! (ohne Gläser) /
in 2 wood versions. With 3 inserts alternatively for glasses S, cups S or creamer (w/o pic.) of CoffeeCulture and cups S CultureCup (w/o pic.).
Not dishwasher-safe! (w/o glasses)

Cromargan®, Holz dunkel gebeizt, Holz lackiert /
stainless 18/10, wood dark stained, wood lacquered

Menage klein dunkel / stand small dark

Größe cm	size in.	
20,5 x 6,2 x 3,7	8 x 2 ¹ / ₂ x 1 ¹ / ₂	55.0039.6040

Menage klein natur / stand small nature

Größe cm	size in.	
20,5 x 6,2 x 3,7	8 x 2 ¹ / ₂ x 1 ¹ / ₂	55.0039.6140

Glas S (VPE 6 Stk.) / glass S (unit 6 pcs.)

Inhalt Ltr.	cap. oz.	Höhe cm	height in.	
0,1	3,4	7,4	3	60.2506.9990



* Artikel einzeln bestellen / please order articles separately



Dessertgestell PURE EXCLUSIV

dessert stand
présentoir à gâteau
soporte plato postre
porta piattini per dessert

in 2 Holzvarianten. Mit 3 Einsätzen für wahlweise Gläser S, Tassen S (o. Abb.) oder Sahnekännchen von KaffeeKultur und Tassen S von CultureCup (o. Abb.). Nicht spülmaschinengeeignet! /
in 2 wood versions. With 3 inserts alternatively for glasses S, cups S (w/o pic.) or creamer of CoffeeCulture and cups S of CultureCup (w/o pic.). Not dishwasher-safe!

Cromargan®, Holz dunkel gebeizt, Holz lackiert /
stainless 18/10, wood dark stained, wood lacquered

Menage klein dunkel / stand small dark

Größe	size	
cm	in.	
20,5 x 6,2 x 3,7	8 x 2 ¹ / ₂ x 1 ¹ / ₂	55.0039.6040

Menage klein natur / stand small nature

Größe	size	
cm	in.	
20,5 x 6,2 x 3,7	8 x 2 ¹ / ₂ x 1 ¹ / ₂	55.0039.6140



Sahnekännchen (VPE 6 Stk.) / creamer (unit 6 pcs.)

Inhalt	cap.	Höhe	height	
Ltr.	oz.	cm	in.	
0,1	3,4	7	2 ³ / ₄	55.0033.9990

Deckel mit Ausschnitt / lid with cut-out 55.0031.6040

Espresso-/Mokkalöffel (VPE 12 Stk.) /
demi-tasse spoon (unit 12 pcs.) 54.9901.6040

* Artikel einzeln bestellen / please order articles separately

Menage PURE EXCLUSIV

menage
menagère, à tapenades
set 3 recipientes
ménage per tapenade

in 2 Holzvarianten. Für Tapenade, Fleur de Sel oder Saucen und Dips /
in 2 wood versions. For tapenade, fleur de sel or dips

Cromargan®, Holz dunkel gebeizt, Holz lackiert /
stainless 18/10, wood dark stained, wood lacquered

Menage klein dunkel / stand small dark

Größe	size	
cm	in.	
20,5 x 6,2 x 3,7	8 x 2 ¹ / ₂ x 1 ¹ / ₂	55.0039.6040

Menage klein natur / stand small nature

Größe	size	
cm	in.	
20,5 x 6,2 x 3,7	8 x 2 ¹ / ₂ x 1 ¹ / ₂	55.0039.6140

Porzellanschälchen (VPE 6 Stk.) / porcelain bowl (unit 6 pcs.)

Inhalt	cap.	Höhe	height	Ø	Ø	
Ltr.	oz.	cm	in.	cm	in.	
0,04	1,4	4	1 ¹ / ₂	5	2	55.0093.9990

Gewürzlöffel (VPE 12 Stk.) / spicy spoon (unit 12 pcs.)

Länge	length	
cm	in.	
7	2 ³ / ₄	54.9184.6040

* Artikel einzeln bestellen / please order articles separately





Dessertgestell

dessert stand
présentoir à gâteau
soporte plato postre
porta piattini per dessert

ohne Gläser /
w/o glasses

Cromargan® / stainless 18/10

Größe	size
cm	in.
40,6 x 7 x 4,9	16 x 2 ³ / ₄ x 2

06.8230.6040

Zubehör / accessory:

Glas S (VPE 6 Stk.) / glass S (unit 6 pcs.)

60.2506.9990



Dessertgestell

dessert stand
présentoir à gâteau
soporte platos postre
porta piattini per dessert

passend für Teller bis Ø 16 cm (ohne Teller) /
fitting for plates Ø 6¹/₄ in. (without plates)

Cromargan® / stainless 18/10

Höhe	height	Ø	Ø	Ø Ring	Ø ring
cm	in.	cm	in.	cm	in.
25,5	10	18,5	7 ¹ / ₄	10,5	4 ¹ / ₄

06.4397.6040



Serviergestell

serving stand
présentoir à assiette
soporte platos
portapiatti

passend für Teller Ø 26 cm (ohne Teller) /
fitting for plates Ø 10¹/₄ in. (without plates)

Cromargan® / stainless 18/10

Höhe	height	Ø	Ø	Ø Ring	Ø ring
cm	in.	cm	in.	cm	in.
40	15 ³ / ₄	28,5	11 ¹ / ₄	18,6	7 ¹ / ₄

06.4395.6040



Kaviarkühler CLASSIC

caviar cooler
refraîchisseur à caviar
enfriador caviar
rinfresca-caviale

	Ø	Ø	Cromargan®	versilbert
	cm	in.	stainless 18/10	silverplated
Unterteil / base	12	4 ³ / ₄	06.3847.6041	19.3847.6441
Einsatz / insert			06.3851.6044	19.3851.6444
Glaseinsatz / glass insert				19.9999.8617



Chillcup CLASSIC

chillcup
chillcup
copa cóctel mariscos
chillcup

mit Ring und Metalleinsatz /
with ring and metal insert

Inhalt	cap.	Ø	Ø
Ltr.	oz.	cm	in.
0,12	4,2	12	4 ³ / ₄

Unterteil / base
Ring / ring

Cromargan® versilbert
stainless 18/10 silverplated
06.3847.6041 19.3847.6441
06.3853.6045 19.3853.6445



Chillcup CLASSIC

chillcup
chillcup
copa cóctel mariscos
chillcup

mit Ring und Glaseinsatz /
with ring and glass insert

Inhalt	cap.	Ø	Ø
Ltr.	oz.	cm	in.
0,12	4,2	12	4 ³ / ₄

Unterteil / base
Ring / ring
Glasschale / glass dish

Cromargan® versilbert
stainless 18/10 silverplated
06.3847.6041 19.3847.6441
06.3853.6045 19.3853.6445
19.9999.8616



Eisschale

ice cream bowl
coupe à glace
copa helado
coppa gelato

Cromargan® / stainless 18/10

Inhalt	cap.	Höhe	height	Ø	Ø
Ltr.	oz.	cm	in.	cm	in.
0,1	3,38	4,5	1 ³ / ₄	10,5	4 ¹ / ₄

55.0093.6040



**Mokkaétagère
CLASSIC**

pastry stand
porte petits fours
portapastas
alzata portadolci

2 Ebenen /
2 levels

versilbert / silverplated

Höhe cm	height in.	Ø Schale cm	Ø bowl in.	
21,5	8 ¹ / ₂	10,7 / 15,5	4 ¹ / ₄ / 6	19.6907.6440



**Mokkaétagère
URBAN**

pastry stand
porte petits fours
portapastas
alzata porta dolci

Cromargan® / stainless 18/10

Höhe cm	height in.	Ø cm	Ø in.	
13,3	5 ¹ / ₄	20	7 ³ / ₄	55.0066.6040



**Mokkaétagère, 3-teilig
PURE**

pastry stand, 3 parts
porte petits fours, en 3 parties
portapastas, de 3 pisos
alzata portadolci, 3 piani

Cromargan® / stainless 18/10

Höhe cm	height in.	Ø Schale cm	Ø bowl in.	
22,5	8 ³ / ₄	9 / 14 / 20	3 ¹ / ₂ / 5 ¹ / ₂ / 8	06.6903.6040



**Mokkaétagère, 2 tlg.
PURE**

pastry stand, 2 parts
porte petits fours, en 2 parties
portapastas, de 2 pisos
alzata portadolci, 2 piani

Cromargan® / stainless 18/10

Höhe cm	height in.	Ø cm	Ø in.	Ø Schale cm	Ø bowl in.	
14,5	5 ³ / ₄	20	7 ³ / ₄	14 / 20	5 ¹ / ₂ / 8	06.8254.6040



Petits Fours-Ständer CLASSIC

petits-fours-stand
porte petits fours
portapastas
alzata porta dolci

Höhe	height	Ø	Ø	Cromargan®	versilbert
cm	in.	cm	in.	stainless 18/10	silverplated
13	5	15,5	6	06.4379.6040	19.4379.6440



Petits Fours-Ständer URBAN

petits-fours-stand
porte petits fours
portapastas
alzata porta dolci

Cromargan® / stainless 18/10

Höhe	height	Ø	Ø	
cm	in.	cm	in.	
8,7	3 1/2	15	6	55.0067.6040



Petits Fours-Ständer PURE EXCLUSIV

petits-fours-stand
porte petits fours
portapastas
alzata porta dolci

in 2 Holzvarianten. **Metall-Aufsatz Petit-Fours und Tischnummernständer können flexibel getauscht werden.** Höhe Holzfuß 10 cm. Holzfuß nicht spülmaschinenfest! /
in 2 wood versions. **Metal support for petits-fours or table number stand can be switched flexibly.** Height of wooden foot 10 cm / 4 in..
Wooden foot not dishwasher-safe!

Cromargan®, Holz dunkel gebeizt, Holz lackiert /
stainless 18/10, wood dark stained, wood lacquered

Höhe	height	Ø	Ø
cm	in.	cm	in.
14	5 1/2	15	6

Holzfuß dunkel / stand dark **55.0121.6040**

Holzfuß natur / stand nature **55.0121.6140**

Petits Fours-Aufsatz / petits-fours-support **55.0121.6042**

Tischnummernständer-Aufsatz / table number stand support **55.0121.6043**

* Artikel einzeln bestellen / please order articles separately





Petits Fours-Ständer

PURE

petits-fours-stand
 porte petits fours
 portapastas
 alzata porta dolci

Cromargan® teilmattiert / stainless 18/10 partly satin finished

Höhe	height	Ø	Ø
cm	in.	cm	in.
10,4	4	15	6

06.0475.6040



Marmeladegestell

jam stand
 support pour confiture
 soporte para mermelada
 supporto per confetture

mit 5 Ablageflächen mit max. Durchm. 4,9 cm, Vase mittig /
 with 5 levels with dia. max. 2 in., flower vase in the middle

Cromargan® / stainless 18/10

Höhe	height
cm	in.
20	7 ³ / ₄

06.8231.6040



Porzellanschale, 3-geteilt

PURE

porcelain bowl 3-section
 coupe en porcelaine 3 parties
 cuenco de porcelana 3 divisiones
 vassoietto tripartito portazzucchero

passend in Tablett 06.7551.6040 /
 fitting in serving tray 06.7551.6040

Porzellan weiß / porcelain white

Größe	size
cm	in.
21 x 8,7 x 3,25	8 ¹ / ₄ x 3 ¹ / ₂ x 1 ¹ / ₄

60.3538.9990



Toastständer

PURE

toast rack
 support pour pain grillé
 portatostadas
 porta-toast

passend in Tablett 06.7551.6040 /
 fitting in serving tray 06.7551.6040

Cromargan® / stainless 18/10

Größe	size
cm	in.
20 x 8 x 6,5	8 x 3 ¹ / ₄ x 2 ¹ / ₂

06.4280.6040



Relish-Pickles-Gestell NEUTRAL

relish or condiment server
service à relish
porta aperitivos
portasalatini / olive

Cromargan® / stainless 18/10

Höhe cm	height in.	Ø Schale cm	dish Ø in.
13	5	8	3 1/4

06.2829.6040



Relish-Pickles-Gestell CLASSIC

relish or condiment server
service à relish
porta aperitivos
portasalatini / olive

Höhe cm	height in.	Ø Schale cm	dish Ø in.	Cromargan® stainless 18/10	versilbert silverplated
19,5	7 3/4	8	3 1/4	06.2846.6040	19.2846.6440



Bargestell, 3teilig

bar-relish dish, 3 pieces
service à relish, 3 parties
soporte de bar, 3 recipientes
set per bar, 3 pezzi

drehbar /
turnable

Cromargan® / stainless 18/10

Höhe cm	height in.	Ø Schale cm	dish Ø in.
19	7 1/2	8	3 1/4

06.2831.6040

Ersatzteil / spare part:
Glasschale / glass dish

19.9999.8616



Eiswasserkrug URBAN

water pitcher
carafe à l'eau
jarra agua
brocca per acqua

mit Eislippe /
with ice-trap

Cromargan® / stainless 18/10

Inhalt Ltr.	cap. oz.	Höhe cm	height in.
1,5	50,7	18,5	7 1/4

06.3371.6041



Eiswasserkrug

SCALA

water pitcher
carafe à l'eau
jarra agua
brocca per acqua

mit Eislippe /
with ice-trap

Inhalt	cap.	Höhe	height	Cromargan®	versilbert
Ltr.	oz.	cm	in.	stainless 18/10	silverplated
1,9	67	23	9	06.1866.6041	19.1866.6441



Eiswasserkrug

water pitcher
carafe à l'eau
jarra agua
brocca per acqua

mit Eislippe /
with ice-trap

Cromargan® / stainless 18/10

Inhalt	cap.	Höhe	height	
Ltr.	oz.	cm	in.	
1,5	52,5	22	8¾	06.1860.6040



Eiswasserkrug

PURE

water pitcher
carafe à l'eau
jarra agua
brocca per acqua

mit Eislippe /
with ice-trap

Cromargan®, teilmattiert /
stainless 18/10, partly satin finished

Inhalt	cap.	Höhe	height	
Ltr.	oz.	cm	in.	
1,9	66,5	20	8	06.1865.6040



Eisgefäß

CLASSIC

ice bucket
seau à glace
cubo hielo
secchiello da ghiaccio

mit Eiseinsatz /
with grid

Cromargan® / stainless 18/10

Inhalt	cap.	Höhe	height	
Ltr.	oz.	cm	in.	
1,5	52,5	12	4¾	06.1761.6040

**Eisgefäß****URBAN**

ice bucket
seau à glace
cubo hielo
secchiello da ghiaccio

doppelwandig /
double wall

Cromargan® / stainless 18/10

Höhe	height	Ø	Ø
cm	in.	cm	in.
15	6	14	5½

55.0065.6040

**Eisgefäß****NEUTRAL**

ice bucket
seau à glace
cubo hielo
secchiello da ghiaccio

Cromargan® / stainless 18/10

Inhalt	cap.	Höhe	height
Ltr.	oz.	cm	in.
1,5	52,5	12	4¾

06.1760.6040

**Eisgefäß****PURE**

ice bucket
seau à glace
cubo hielo
secchiello da ghiaccio

Cromargan® teilmattiert / stainless 18/10 partly satin finished

Inhalt	cap.	Höhe	height
Ltr.	oz.	cm	in.
1,5	52,5	15	6

06.1767.6040

**Eisgefäß**

ice bucket
seau à glace
cubo hielo
secchiello da ghiaccio

doppelwandig /
double wall

Cromargan® / stainless 18/10

Inhalt	cap.	Höhe	height	Ø	Ø
Ltr.	oz.	cm	in.	cm	in.
0,7	23,66	15	6	12,5	5

55.0035.6040

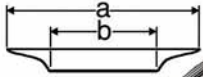

**Platzteller
RESIDENCE**

plate tray
assiette de présentation
bajoplato
piatto segnaposto

Cromargan® / stainless 18/10

Ø a	Ø a	Ø b	Ø b
cm	in.	cm	in.
33	13	19	7½

06.7473.6090*

* Rand geprägt / striked rim

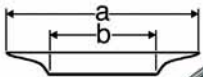

Platzteller

plate tray
assiette de présentation
bajoplato
piatto segnaposto

Ø a	Ø a	Ø b	Ø b	Cromargan®	versilbert
cm	in.	cm	in.	stainless 18/10	silverplated
32	12½	19	7½	06.7416.9990*	19.7416.6440*
33	13	21	8¼	06.7417.6040**	

* für Teller Ø 28 cm / for plates Ø 11 in.

** für Teller Ø 30 cm / for plates Ø 11¾ in.



**Teller cloche
CLASSIC**

plate cover
cloche pour assiette
campana con pomolo
copripiatto con pomolo

auflegend /
salient

Ø Fond	Ø inside	Höhe	height	Cromargan®	versilbert
cm	in.	cm	in.	stainless 18/10	silverplated
25	9¾	17	6¾	06.7148.6040	19.7148.6440



**Teller cloche
NEUTRAL**

plate cover
cloche pour assiette
campana con pomolo
copripiatto con pomolo

auflegend /
salient

Cromargan® / stainless 18/10

Ø Fond	Ø inside	Höhe	height
cm	in.	cm	in.
25	9¾	16,5	6⅔

06.7113.6040

**Teller cloche**

plate cover
 cloche pour assiette
 campana
 copripiatto con pomolo

stapelbar /
 stackable

Cromargan® / stainless 18/10

Ø Fond cm	Ø inside in.	Höhe cm	height in.	
26	10 ¹ / ₄	5,3	2	06.7089.6040
27,1	10 ³ / ₄	5,3	2	06.7086.6040
28	11	5,3	2	06.7087.6040

**Eierbecher-Set**

egg cup set
set de coquetier
set de huevera
set portauovo

stapelbar /
stackable

Cromargan® / stainless 18/10

Ø	Ø	Stück
cm	in.	pcs.
8,5	3 ¹ / ₃	6

06.1640.6040

Eierlöffel

egg spoon
cuiller à oeuf
cuchara huevos
cucchiaio per uovo



Cromargan® / stainless 18/10

Länge	length
cm	in.
13	5

12.9008.6040*

* VPE 12 Stk. / unit 12 pcs.

Tischrestebehälter**PURE**

silent waiter
boîte de table
recipiente desperdicios
porta rifiuti per tavolo



Deckel zum Abnehmen, auch als Kühler für kleine Flaschen einsetzbar,
stapelbar /
detachable lid, can also be used to cool small bottles, stackable

Cromargan® teil mattiert / stainless 18/10 partly satin finished

Höhe	height	Ø	Ø
cm	in.	cm	in.
15	6	14	5 ¹ / ₂

06.1758.6040

Krümelsammler

table crumbler
ramasse-brosse
recogemigas
raccoglibriciole



Cromargan® / stainless 18/10

Länge	length
cm	in.
15	6

06.7707.6000



**Zahnstocherbehälter
CLASSIC**

toothpick-holder
porte-cure-dents
palillero
porta stuzzicadenti

Höhe	height
cm	in.
6	2 ¹ / ₄

rostfrei	versilbert
stainless steel	silverplated
06.8406.1680	19.8406.1440



**Zahnstocherbehälter
PURE**

toothpick-holder
porte-cure-dents
palillero
porta stuzzicadenti

Cromargan®, teilmattiert /
stainless 18/10, partly satin finished

Höhe	height
cm	in.
7	2 ³ / ₄

06.8413.6040



**Zahnstocher- und Süßstoffbehälter
PURE**

toothpick- and sweetener box-holder
porte-cure-dents et récipient pour sucrées
palillero y dispensador de edulcorante
porta stuzzicadenti e contenitore per dolcificante

zum Einhängen in alle WMF PURE-Gestelle mit Bügelgriff.
Laser-Gravur der Tischnummer nach Wunsch - Preis auf Anfrage /
fitting in all racks of WMF PURE sets. Engraving of the table No. on
request - please ask for respective costs

Cromargan® / stainless 18/10

Höhe	height
cm	in.
4	1 ¹ / ₂

06.1905.6044



**Ascher
PURE**

ash tray
cendrier
cenicero
posacenere

stapelbar /
stackable

Cromargan®, teilmattiert /
stainless 18/10, partly satin finished

Höhe	height	Ø	Ø
cm	in.	cm	in.
5	2	14	5 ¹ / ₂

06.5552.6040



Zigarrenabschneider

cigar cutter
coupe-cigares
cortapuros
spuntasigari

Edelstahl 18/10 / stainless 18/10

Länge	length
cm	in.
10	4

55.0094.6040



Tischnummernständer CLASSIC

table number stand
porte numéro de table
porta número de mesa
targhetta ad appoggio per numero tavolo

individuelle Gravur nach Wunsch - Preis auf Anfrage. Tischnummer nicht entfernbar. /

individual engraving on request - please ask for respective costs. Table number not removable.

Cromargan® / stainless 18/10

Höhe	height
cm	in.
54	21 ¹ / ₄

06.7819.6040



Tischnummernständer, mit Clip CLASSIC

table number stand, with clip
porte numéro de table, avec clip
porta número de mesa, con clip
segnatavola, con clip

Tischnummer separat zum Einstecken. /
Table No. to be put in separately.

Cromargan® / stainless 18/10

Höhe	height	Ø	Ø
cm	in.	cm	in.
45,4	17 ³ / ₄	9,7	3 ³ / ₄

06.8250.6040

Zubehör / accessory:

Tischnummer / table number

06.8252.6040

Plastik-Tischnummer / plastic table number

19.9999.2513



Tischnummernständer

PURE

table number stand
 porte numéro de table
 porta número de mesa (sin número)
 segnatavola

Cromargan®, teilmattiert /
 stainless 18/10, partly satin finished

Höhe	height
cm	in.
30,5	12

06.7812.6040

Zubehör / accessory:

Plastik-Tischnummer / plastic table number
 Tischnummer / table number

19.9999.2513
 06.8252.6040



Tischnummernständer

PURE EXCLUSIV

table number stand
 porte numéro de table
 porta número de mesa
 segnatavola

in 2 Holzvarianten. **Metall-Aufsatz Petit-Fours und Tischnummernständer kann flexibel getauscht werden.** Holzfuß nicht spülmaschinenfest! /

in 2 wood versions. **Metal part for petits-fours or table number stand can be switched flexibly.** Wooden foot not dishwasher-safe!

Cromargan®, Holz dunkel gebeizt, Holz lackiert /
 stainless 18/10, wood dark stained, wood lacquered

Höhe	height
cm	in.
36,8	14 ¹ / ₂

Holzfuß dunkel / stand dark **55.0121.6040**

Holzfuß natur / stand nature **55.0121.6140**

Petits Fours-Aufsatz / petits-fours-support **55.0121.6042**

Tischnummernständer-Aufsatz / table number stand support **55.0121.6043**

* Artikel einzeln bestellen / please order articles separately



Tischnummernständer

table number stand
 porte numéro de table
 porta número de mesa (sin grabación)
 targhetta ad appoggio per numero tavolo

Cromargan® / stainless 18/10

Höhe	height
cm	in.
28	11

06.7719.1680



Tischnummern-Aufsteller

table number
 numéro de table
 número de mesa
 numero tavolo

passend zu Tischnummernständer 06.7719.1680, Laser-Gravur nach Wunsch - Preis auf Anfrage /
 fitting for table number stand 06.7719.1680, engraving on request - please ask for respective costs

Länge	length	Höhe	height	Cromargan®	versilbert
cm	in.	cm	in.	stainless 18/10	silverplated
8,3	3 1/4	3,6	1 1/2	06.7701.6040	19.7701.6440



Kartenhalter PURE EXCLUSIV

card holder
 porte-carte
 portatarjetas
 portacarta

in 2 Holzvarianten. Für Tisch- und Visitenkarten (ohne Karte) /
 in 2 wood versions. For menu and name cards (without card)

Cromargan®, Holz dunkel gebeizt, Holz lackiert /
 stainless 18/10, wood dark stained, wood lacquered

Kartenhalter dunkel / card holder dark

Größe	size
cm	in.
4,5 x 4,5 x 6,5	1 3/4 x 1 3/4 x 2 1/2

55.0080.6040

Kartenhalter natur / card holder nature

Größe	size
cm	in.
4,5 x 4,5 x 6,5	1 3/4 x 1 3/4 x 2 1/2

55.0080.6140



Speisekartenhalter

PURE

menu stand
 porte menu
 porta menus
 portamenu

Cromargan®, teilmattiert /
 stainless 18/10, partly satin finished

Höhe	height
cm	in.
7,5	3

06.7813.6040

Zubehör / accessory:

Plastik-Tischnummer / plastic table number
 Tischnummer / table number

19.9999.2513
 06.8252.6040



Tischnummer

table number
 numéro de table
 número de mesa
 numero tavolo

passend zu Tischnummernständer 06.8250.6040, 06.7812.6040,
 55.0121.6043 und Speisekartenhalter 06.7813.6040. Individuelle Gravur
 nach Wunsch - Preis auf Anfrage /
 fitting for table number stand 06.8250.6040, 06.7812.6040,
 55.0121.6043 and menu stand 06.7813.6040. Individual engraving on
 request - please ask for respective costs

Cromargan® / stainless 18/10

Ø	Ø
cm	in.
13,5	5 1/4

06.8252.6040



Plastik-Tischnummer

plastic table number
 numéro de table en plastique
 número de mesa plástico
 numero tavolo in plastica

passend in Tischnummernständer 06.7812.6040, 06.8250.6040,
 55.0121.6043 und Speisekartenhalter 06.7813.6040 /
 fitting in table number stand 06.7812.6040, 06.8250.6040,
 55.0121.6043 and menu stand 06.7813.6040

Größe	size
cm	in.
10 x 10	4 x 4

19.9999.2513



Dosenöffner

can opener
 ouvre-boîte
 abrelatas
 abriscatole

ganz Metall. Hinterlässt keine scharfen Kanten am Dosendeckel, Deckel kann wieder aufgesetzt werden. /
 all metal. Does not leave sharp edges on the can lid - lid can be replaced on can.

Cromargan® / stainless 18/10

Länge	length
cm	in.
20	8

18.7319.6040



Korkenzieher

cork-screw
 tire-bouchon
 sacacorchos
 cavatappi

Cromargan® / stainless 18/10

Länge	length
cm	in.
17,5	7

18.8252.6019



Früchtekorb

fruit basket
panier à fruits
frutero
fruttiera

passend in Etagère 06.3010.6040, 06.3011.6040 nur in Verbindung mit
Kühlbehälter 06.3014.6045 (bitte separat bestellen) /
fitting together with cooler 06.3014.6045 (please order separately) in
etagere 06.3010.6040, 06.3011.6040

Cromargan® / stainless 18/10

Höhe	height	Ø	Ø
cm	in.	cm	in.
22,5	8 ³ / ₄	26	10 ¹ / ₄

06.6521.6040



**Brotkorb, rund
OLE PALSBY**

bread-basket, round
panier à pain, rond
cesta del pan, redonda
cestino per il pane, rotondo

Cromargan® / stainless 18/10

Ø	Ø
cm	in.
18	7 ¹ / ₂
21	8 ¹ / ₄
26	10 ¹ / ₄

06.6575.6040

06.6513.6040

06.6514.6040



**Brotkorb
PURE**

bowl for bread
panier à pain
panera
portapane

stapelbar /
stackable

Cromargan® teilmattiert / stainless 18/10 partly satin finished

Größe	size
cm	in.
25 x 14 x 5	9 ³ / ₄ x 5 ¹ / ₂ x 2

06.6535.6040





Brotkorb

bread-basket
panier à pain
cesta del pan
cestino per il pane

nicht mit Wasser oder Chemikalien reinigen. Reinigung nur im Silbertauchbad oder mit speziellen Pflegemitteln für Silberartikel /
do not clean with water or chemicals. Cleaning only in silver-dip-bath or with special polish for silver articles

versilbert / silverplated

Größe	size	
cm	in.	
22,3 x 16,3 x 6	8 ³ / ₄ x 6 ¹ / ₂ x 2 ¹ / ₄	
27 x 19 x 6,5	10 ³ / ₄ x 7 ¹ / ₂ x 2 ¹ / ₂	

19.6319.7030
19.6329.6440



BrotSchale

bowl for bread
panier à pain
panera
portapane

Größe	size		
cm	in.		
28 x 17	11 x 6 ³ / ₄		

Cromargan® versilbert
stainless 18/10 silverplated
06.6380.6040 **19.6380.6440**



BrotSchale

bowl for bread
panier à pain
panera
portapane

oval, Durchbruchdekor /
oval, stencil pattern

Cromargan® / stainless 18/10

Größe	size	
cm	in.	
20 x 15	8 x 6	

06.6571.6040



Universalschale PURE

universal dish
coupe universelle
recipiente universal
ciotola universale

stapelbar /
stackable

Cromargan® teilmatteiert / stainless 18/10 partly satin finished

Höhe	height	Ø Schale	dish Ø
cm	in.	cm	in.
5,5	2 ¹ / ₄	12	4 ³ / ₄

06.1799.6040

**Universalschale**

finger bowl
coupe universelle
recipiente universal
ciotola universale

Cromargan® / stainless 18/10

Inhalt	cap.	Ø Schale	dish Ø
Ltr.	oz.	cm	in.
0,2	7	12	4 ³ / ₄

06.1849.6040**Obstschale
BISTRO**

fruit stand
coupe à fruits
frutero
alzata per frutta

Cromargan®, Glas / stainless 18/10, glass

Höhe	height	Ø Schale	Ø bowl
cm	in.	cm	in.
16	6 ¹ / ₄	38	15

06.6895.6040

Ersatzteil / spare part:

Glasschale mittel / glass plate medium

19.9999.8644

**Obstschale**

fruit bowl
coupe à fruits
frutero
alzata per frutta

Cromargan® / stainless 18/10

Größe	size
cm	in.
22,5 x 22,5 x 7,2	8 ³ / ₄ x 8 ³ / ₄ x 2 ³ / ₄

06.8236.6040



Leuchter, 3-flammig URBAN

candelabra, 3-branched
chandelier, 3 branches
candelabro, 3 brazos
candelieri, 3 fiamme

Cromargan® / stainless 18/10

Länge cm	length in.	Höhe cm	height in.
23,8	9 ¹ / ₄	22,5	8 ³ / ₄

55.0069.6040

Leuchter, 3-armig PURE

candelabra, 3-branched
chandelier, 3 branches
candelabro, 3 brazos
candelieri, 3 fiamme

Cromargan®, teilmattiert /
stainless 18/10, partly satin finished

Höhe cm	height in.
36	14 ¹ / ₄

06.4753.6040



Leuchter, 5-armig PURE

candelabra, 5-branched
chandelier, 5 branches
candelabro, 5 brazos
candelieri, 5 fiamme

Cromargan®, teilmattiert /
stainless 18/10, partly satin finished

Höhe cm	height in.
36	14 ¹ / ₄

06.4754.6040





**Leuchter
CLASSIC**

candle stick
chandelier
candelero
candeliere

versilbert / silverplated

Höhe	height
cm	in.
12	4 ³ / ₄

19.4990.6440



**Leuchter
URBAN**

candle stick
chandelier
candelero
candeliere

Cromargan® / stainless 18/10

Länge	length	Höhe	height
cm	in.	cm	in.
6,4	2 ¹ / ₂	21	8 ¹ / ₄

55.0060.6040



**Leuchter
PURE EXCLUSIV**

candle stick
chandelier
candelero
candeliere

Cromargan®, Holz dunkel gebeizt /
stainless 18/10, wood dark stained

Höhe	height	Ø	Ø
cm	in.	cm	in.
20,4	8	9	3 ¹ / ₂
30,4	12	9	3 ¹ / ₂

55.0018.6040

55.0017.6040



**Leuchter
PURE**

candle stick
chandelier
candelero
candeliere

Cromargan®, teilmattiert /
stainless 18/10, partly satin finished

Höhe	height
cm	in.
10,5	4 ¹ / ₄

06.4751.6040



Windlicht

PURE

table lamp with glass
 chandelier avec verrine
 linterna con cristal
 lampa da tavola alta con paralume

ohne Kerzen. Für Teelichter /
 w/o candles. For tealights

Cromargan®, teilmattiert, Glas /
 stainless 18/10, partly satin finished, glass

Höhe	height
cm	in.
21	8 ¹ / ₄

06.8202.6040

Ersatzteil / spare part:
 Ersatzglas / spare glass

60.3051.9990



Windlicht, matt

PURE

table lamp with glass, satin
 chandelier avec verrine, mat
 linterna con cristal, mate
 lampa da tavola alta con paralume, di vetro satino

ohne Kerzen. Für Teelichter /
 w/o candles. For tealights

Cromargan®, teilmattiert, Glas /
 stainless 18/10, partly satin finished, glass

Höhe	height
cm	in.
21	8 ¹ / ₄

06.8208.6040

Ersatzteil / spare part:
 Ersatzglas / spare glass

60.3052.9990



Windlicht

URBAN

table lamp
 chandelier avec verrine
 linterna con cristal
 lampa da tavola alta con paralume

ohne Kerzen. Für große Teelichter /
 w/o candles. For big tealights

Cromargan®, Glas / stainless 18/10, glass

Höhe	height	Ø	Ø
cm	in.	cm	in.
13,5	5 ¹ / ₄	8	3 ¹ / ₄

55.0070.6040

Ersatzteil / spare part:
 Ersatzglas zu Windlicht / spare glass for table lamp

55.0070.9990



**Windlicht, groß
PURE EXCLUSIV**

table lamp, large
chandelier avec verrine, grand
linterna con cristal, alta
lampa da tavola alta con paralume, grande

in 2 Holzvarianten. Ohne Kerzen. Für große Teelichter. Nicht
spülmaschinengeeignet! /
in 2 wood versions. W/o candles. For big tealights. Not dishwasher-safe!

Cromargan®, Holz dunkel gebeizt, Holz lackiert, Glas satiniert /
stainless 18/10, wood dark stained, wood lacquered, glass satin finished

Windlicht, groß dunkel / table lamp, large dark

Größe	size	Ø	Ø	
cm	in.	cm	in.	
8 x 8 x 22,3	3 ¹ / ₄ x 3 ¹ / ₄ x 8 ³ / ₄	13	5	55.0040.6040

Windlicht, groß natur / table lamp, large nature

Größe	size	Ø	Ø	
cm	in.	cm	in.	
8 x 8 x 22,3	3 ¹ / ₄ x 3 ¹ / ₄ x 8 ³ / ₄	13	5	55.0040.6140

Ersatzteil / spare part:

Ersatzglas zu Windlicht groß /
spare glass for table lamp large 55.0040.6042

**Windlicht, klein
PURE EXCLUSIV**

table lamp, small
chandelier avec verrine, petit
linterna con cristal, pequeno
lampa da tavola alta c. paralum, picc.

in 2 Holzvarianten. Ohne Kerzen. Für Teelichter. Nicht
spülmaschinengeeignet! /
in 2 wood versions. W/o candles. For tealights. Not dishwasher-safe!

Cromargan®, Holz dunkel gebeizt, Holz lackiert, Glas satiniert /
stainless 18/10, wood dark stained, wood lacquered, glass satin finished

Windlicht, klein dunkel / table lamp, small dark

Größe	size	Ø	Ø	
cm	in.	cm	in.	
6,3 x 6,3 x 19,3	2 ¹ / ₂ x 2 ¹ / ₂ x 7 ¹ / ₂	9,5	3 ³ / ₄	55.0075.6040

Windlicht, klein natur / table lamp, small nature

Größe	size	Ø	Ø	
cm	in.	cm	in.	
6,3 x 6,3 x 19,3	2 ¹ / ₂ x 2 ¹ / ₂ x 7 ¹ / ₂	9,5	3 ³ / ₄	55.0075.6140

Ersatzteil / spare part:

Ersatzglas zu Windlicht klein /
spare glass for table lamp small 55.0075.6042





**Teelichtleuchter 3fl. klein
PURE EXCLUSIV**

tealight candle stick, small
chandelier bougie à chauffe-plat
candelero lamparilla, peq.
candeliere lumino, picc.

in 2 Holzvarianten. Mit 3 Einsätzen für Teelichter, Stab- oder
Stumpenkerzen. Nicht spülmaschinengeeignet! /
in 2 wood versions. With 3 inserts for tealights and other kinds of
candles. Not dishwasher-safe!

Cromargan®, Holz dunkel gebeizt, Holz lackiert /
stainless 18/10, wood dark stained, wood lacquered

Menage klein dunkel / stand small dark

Größe	size	
cm	in.	
20,5 x 6,2 x 3,7	8 x 2 ¹ / ₂ x 1 ¹ / ₂	

55.0039.6040

Menage klein natur / stand small nature

Größe	size	
cm	in.	
20,5 x 6,2 x 3,7	8 x 2 ¹ / ₂ x 1 ¹ / ₂	

55.0039.6140



**Blumenvase
CLASSIC**

flower vase
vase à fleurs
florero
vaso da fiori

versilbert / silverplated

Höhe	height
cm	in.
16,5	6 ¹ / ₂

19.7962.1440



**Blumenvase
URBAN**

flower vase
vase à fleurs
florero
vaso da fiori

Cromargan® / stainless 18/10

Höhe	height	Ø	Ø
cm	in.	cm	in.
17,5	7	7	2 ³ / ₄

55.0061.6040



**Blumenvase
PURE**

flower vase
vase à fleurs
florero
vaso da fiori

Cromargan®, teilmattiert /
stainless 18/10, partly satin finished

Höhe	height
cm	in.
20	8

06.7955.6040



Blumenvase

flower vase
vase à fleurs
florero
vaso da fiori

Cromargan® / stainless 18/10

Höhe	height	Ø	Ø
cm	in.	cm	in.
30	11 ³ / ₄	10	4

06.8240.6040



Blumenvase, klein PURE EXCLUSIV

flower vase, small
vase à fleurs, petit
florero, pequeno
vaso da fiori, piccolo

in 2 Holzvarianten. Für einzelne Blüten. Nicht spülmaschinengeeignet! /
in 2 wood versions. For single flowers. Not dishwasher-safe!

Cromargan®, Holz dunkel gebeizt, Holz lackiert /
stainless 18/10, wood dark stained, wood lacquered

Blumenvase, klein dunkel / flower vase, small dark

Größe	size	Ø	Ø
cm	in.	cm	in.
4,5 x 4,5 x 16	1 ³ / ₄ x 1 ³ / ₄ x 6 ¹ / ₄	2,8	1

55.0041.6040

Blumenvase, klein natur / flower vase, small nature

Größe	size	Ø	Ø
cm	in.	cm	in.
4,5 x 4,5 x 16	1 ³ / ₄ x 1 ³ / ₄ x 6 ¹ / ₄	2,8	1

55.0041.6140



Blumenvase, groß PURE EXCLUSIV

flower vase, large
vase à fleurs, grande
florero, grande
vaso da fiori, grande

in 2 Holzvarianten. Nicht spülmaschinengeeignet! /
in 2 wood versions. Not dishwasher-safe!

Cromargan®, Holz dunkel gebeizt, Holz lackiert /
stainless 18/10, wood dark stained, wood lacquered

Blumenvase, groß dunkel / flower vase, large dark

Größe	size	Ø	Ø
cm	in.	cm	in.
8 x 8 x 23,5	3 ¹ / ₄ x 3 ¹ / ₄ x 9 ¹ / ₄	5,2	2

55.0042.6040

Blumenvase, groß natur / flower vase, large nature

Größe	size	Ø	Ø
cm	in.	cm	in.
8 x 8 x 23,5	3 ¹ / ₄ x 3 ¹ / ₄ x 9 ¹ / ₄	5,2	2

55.0042.6140



Salzmühle / Pfeffermühle

salt mill / pepper mill
 moulin à sel / moulin à poivre
 molinillo sal / molinillo pimienta
 macinasale / macinapepe

mit original Keramikmahlwerk /
 with ceramic grinding mechanism

Cromargan®, Acrylglas / stainless 18/10, acrylic glass

Höhe	height	Ø	Ø	
cm	in.	cm	in.	
12	4 ³ / ₄	5	2	06.1510.6040
16	6 ¹ / ₄	5	2	06.3531.6040



Salzmühle / Pfeffermühle

salt mill / pepper mill
 moulin à sel / moulin à poivre
 molinillo sal / molinillo pimienta
 macinasale / macinapepe

mit original Keramikmahlwerk. Passend in die großen Ausschnitte der Menagen PURE EXCLUSIV /
 with ceramic grinding mechanism. Fitting in the big cut-outs of the stands high PURE EXCLUSIV

Cromargan®, Holz lackiert / stainless 18/10, wood lacquered

Höhe	height
cm	in.
19	7 ¹ / ₂

Salzmühle / Pfeffermühle weiß /
 salt mill / pepper mill white **06.6708.4500**

Salzmühle / Pfeffermühle schwarz /
 salt mill / pepper mill black **06.6709.4500**

**Salzstreuer / Pfefferstreuer
 URBAN**

salt shaker / pepper shaker
 moulin à sel / moulin à poivre
 molinillo sal / molinillo pimienta
 macinasale / macinapepe

einzelnd stehend oder passend auf Tablett URBAN oder in kleine Ausschnitte von PURE EXCLUSIV Teelichthalter und Menage. /
 stand alone or fitting on tray URBAN or in small cut-outs of PURE EXCLUSIV tealight holder or menage



Cromargan® / stainless 18/10

Höhe	height	Ø	Ø
cm	in.	cm	in.
8,5	3 ¹ / ₄	4,5	1 ³ / ₄

Salzstreuer / salt shaker **55.0062.6040**

Pfefferstreuer / pepper shaker **55.0063.6040**

Ersatzteil / spare part:
 Stopfen zu Streuer / stopper for shakers **55.0062.9502**



Salz- und Pfeffergestell CLASSIC

salt-pepper-set
ménagère 2 pièces
servicio condimento
menage

Höhe	height
cm	in.
12,3	5

Cromargan®	versilbert
stainless 18/10	silverplated
06.5171.6040	19.5171.6440

Ersatzteil / spare part:
Salzstreuer / salt shaker
Pfefferstreuer / pepper shaker
Ersatzglas / spare glass

06.6037.6040	19.6037.6440
06.6038.6040	19.6038.6440
	60.6037.9990



Salz- und Pfeffergestell PURE

salt-pepper-set
ménagère 2 pièces
servicio condimento
menage

Cromargan®, Kappen mattiert, Glas /
stainless 18/10, tops satin finished, glass

Höhe	height
cm	in.
14,5	5¾

06.5170.6040

Ersatzteil / spare part:
Salzstreuer / salt shaker
Pfefferstreuer / pepper shaker
Ersatzglas / spare glass

06.6062.6030
06.6063.6030
60.8253.9960



Essig-/Ölgestell CLASSIC

oil and vinegar set
huilier-vinaigrier
vinagreras
oliera

Höhe	height
cm	in.
23	9

Cromargan®	versilbert
stainless 18/10	silverplated
06.1906.6040	19.1906.6440

Ersatzteil / spare part:

Ersatzflasche / spare bottle				19.9999.8632
Höhe	height	Inhalt	cap.	
cm	in.	Ltr.	oz.	
19	7,5	0,15	5,22	



**Essig-/Öl-Set
URBAN**

oil and vinegar set
huilier-vinaigrier
vinagreras
oliera

bestehend aus Tablett, Essig- und Ölflasche, Salz- und Pfefferstreuer. /
consisting of tray, oil and vinegar bottle, salt and pepper shaker

Cromargan®, Glas / stainless 18/10, glass

Tablett / tray	55.0058.6045
Essig-/Ölflasche / oil/vinegar bottle	55.0059.6040
Salzstreuer / salt shaker	55.0062.6040
Pfefferstreuer / pepper shaker	55.0063.6040

Ersatzteil / spare part:

Stopfen zu Streuer / stopper for shakers	55.0062.9502
Ausgießer zu Essig-/Ölflasche / pouir for oil/vinegar bottle	55.0059.9802
Deckel zu Essig-/Ölflasche / lid for oil/vinegar bottle	55.0059.6803

* Artikel einzeln bestellen / please order articles separately



**Tablett
URBAN**

tray
plateau
bandeja
vassoio

Cromargan® / stainless 18/10

Größe	size
cm	in.
23 x 10,7	8 x 4 1/4

55.0058.6045



**Essig-/Ölflasche
URBAN**

oil/vinegar bottle
burette à vinaigre/huile
botella de aceite/vinagre
caraffa per aceto/olio

Cromargan®, Glas / stainless 18/10, glass

Höhe	height	Inhalt	cap.	Ø	Ø	
cm	in.	Ltr.	oz.	cm	in.	
15,2	6	0,15	5,07	5,7	2 1/4	55.0059.6040

Ersatzteil / spare part:

Ausgießer zu Essig-/Ölflasche / pouir for oil/vinegar bottle	55.0059.9802
Deckel zu Essig-/Ölflasche / lid for oil/vinegar bottle	55.0059.6803



Essig-/Ölgestell, 3 tlg.

PURE

oil and vinegar set, 3 pcs.
 huilier-vinaigrier, 3 parties
 vinagreras, 3 piezas
 oliera, a 3 vaschette

bestehend aus Gestell, Essig- und Ölflasche und Glasbehälter für Senf, Parmesan, Sambal Oelek u.a. /
 consisting of: stand, oil / vinegar bottle and glass pots for mustard, parmesan, relish, etc.

Cromargan®, Glas / stainless 18/10, glass

Gestell hoch / stand high

Höhe	height	Ø	Ø	
cm	in.	cm	in.	
21	8 ¹ / ₄	14	5 ¹ / ₂	06.2341.6045

einzelne Flasche komplett / spare bottle complete

Höhe	height	Inhalt	cap.	
cm	in.	Ltr.	oz.	
16	6 ¹ / ₂	0,2	6,96	06.6139.6030

Glas S (VPE 6 Stk.) / glass S (unit 6 pcs.)

Höhe	height	Inhalt	cap.	
cm	in.	Ltr.	oz.	
7,4	3	0,1	3,4	60.2506.9990

Ring S (VPE 6 Stk.) / ring S (unit 6 pcs.)

06.2502.6040

Deckel mit Ausschnitt / lid with cut-out

55.0031.6040

Espresso-/Mokkalöffel (VPE 12 Stk.) /
 demi-tasse spoon (unit 12 pcs.)

54.9901.6040

* Artikel einzeln bestellen / please order articles separately



Essig-/Ölgestell, 4 tlg.

PURE

oil and vinegar set, 4 pcs.
 huilier-vinaigrier, 4 parties
 vinagreras, 4 piezas
 oliera, a 4 vaschette

bestehend aus: Gestell, Essig- und Ölflasche, Salz- und Pfefferstreuer /
 consisting of: stand, oil / vinegar bottle, salt / pepper shaker

Cromargan® / stainless 18/10

Höhe	height	Ø	Ø	
cm	in.	cm	in.	
21,1	8 ¹ / ₂	14	5 ¹ / ₂	06.2341.6040

Ersatzteil / spare part:

Gestell hoch / stand high

06.2341.6045

Höhe	height	Ø	Ø
cm	in.	cm	in.
21	8 ¹ / ₄	14	5 ¹ / ₂

Salzstreuer / salt shaker

06.6062.6030

Höhe	height	Ø	Ø
cm	in.	cm	in.
11	4 ¹ / ₄	4,1	1 ¹ / ₂

Pfefferstreuer / pepper shaker

06.6063.6030

Höhe	height	Ø	Ø
cm	in.	cm	in.
11	4 ¹ / ₄	4,1	1 ¹ / ₂

einzelne Flasche komplett / spare bottle complete

06.6139.6030

Höhe	height	Inhalt	cap.
cm	in.	Ltr.	oz.
16	6 ¹ / ₂	0,2	6,96



**Essig-/Öl-Menage
PURE EXCLUSIV**

oil and vinegar set
huilier-vinaigrier
vinagreras
oliera

in 2 Holzvarianten. Mit 4 Einsätzen für Salz- und Pfefferstreuer, Essig- und Ölflasche von URBAN. Nicht spülmaschinengeeignet! /
in 2 wood versions. With 4 inserts for salt shaker, pepper shaker, oil/ vinegar bottle of URBAN. Not dishwasher-safe!

Cromargan®, Holz dunkel gebeizt, Holz lackiert /
stainless 18/10, wood dark stained, wood lacquered

Menage groß dunkel / stand large dark

Größe	size	
cm	in.	
14,5 x 14,5 x 25,4	5 ³ / ₄ x 5 ³ / ₄ x 10	55.0034.6040

Menage groß natur / stand large nature

Größe	size	
cm	in.	
14,5 x 14,5 x 25,4	5 ³ / ₄ x 5 ³ / ₄ x 10	55.0034.6140

Essig-/Ölflasche / oil/vinegar bottle

Höhe	height	Inhalt	cap.	Ø	Ø	
cm	in.	Ltr.	oz.	cm	in.	
15,2	6	0,15	5,07	5,7	2 ¹ / ₄	55.0059.6040

Salzstreuer / salt shaker

Höhe	height	Ø	Ø	
cm	in.	cm	in.	
8,5	3 ¹ / ₄	4,5	1 ³ / ₄	55.0062.6040

Pfefferstreuer / pepper shaker

Höhe	height	Ø	Ø	
cm	in.	cm	in.	
8,5	3 ¹ / ₄	4,5	1 ³ / ₄	55.0063.6040

* Artikel einzeln bestellen / please order articles separately



Essig-Öl-Menage PURE EXCLUSIV

oil and vinegar set
huilier-vinaigrier
vinagreras
oliera

in 2 Holzvarianten. Gestell mit 4 Einsätzen für Flaschen und Streuer.
Nicht spülmaschinengeeignet! /
in 2 wood versions. Stand with 4 inserts for bottles and shaker. Not
dishwasher-safe!

Cromargan®, Holz dunkel gebeizt, Holz lackiert /
stainless 18/10, wood dark stained, wood lacquered

Menage groß dunkel / stand large dark

Größe	size	
cm	in.	
14,5 x 14,5 x 25,4	5 ³ / ₄ x 5 ³ / ₄ x 10	55.0034.6040

Menage groß natur / stand large nature

Größe	size	
cm	in.	
14,5 x 14,5 x 25,4	5 ³ / ₄ x 5 ³ / ₄ x 10	55.0034.6140

einzelne Flasche komplett / spare bottle complete

Höhe	height	Inhalt	cap.
cm	in.	Ltr.	oz.
16	6 ¹ / ₂	0,2	6,96
			06.6139.6030

Salzstreuer / salt shaker

Höhe	height	Ø	Ø
cm	in.	cm	in.
11	4 ¹ / ₄	4,1	1 ¹ / ₂
			06.6062.6030

Pfefferstreuer / pepper shaker

Höhe	height	Ø	Ø
cm	in.	cm	in.
11	4 ¹ / ₄	4,1	1 ¹ / ₂
			06.6063.6030

* Artikel einzeln bestellen / please order articles separately



**Essig-/Öl-Menage
PURE EXCLUSIV**

oil and vinegar set
huilier-vinaigrier
vinagreras
oliera

in 2 Holzvarianten. Mit 4 Einsätzen für kleine Essig-/Ölflasche PURE, große Essig-Ölflasche PURE, Tassen S mit oder ohne Deckel von KAFFEEKULTUR und Mühle. Nicht spülmaschinengeeignet! / in 2 wood versions. With 4 inserts for small oil/vinegar bottle PURE, large oil/vinegar bottle PURE, cup S with or w/o lid of CoffeeCulture and mill. Not dishwasher-safe!

Cromargan®, Holz dunkel gebeizt, Holz lackiert / stainless 18/10, wood dark stained, wood lacquered

Menage groß dunkel / stand large dark

Größe	size	
cm	in.	
14,5 x 14,5 x 25,4	5 ³ / ₄ x 5 ³ / ₄ x 10	55.0034.6040

Menage groß natur / stand large nature

Größe	size	
cm	in.	
14,5 x 14,5 x 25,4	5 ³ / ₄ x 5 ³ / ₄ x 10	55.0034.6140

Essig-/Ölflasche, klein / oil and vinegar bottle

Höhe	height	Ø	Ø
cm	in.	cm	in.
13	5	4,1	1 ¹ / ₂
			55.0098.6040

einzelne Flasche komplett / spare bottle complete

Höhe	height	Inhalt	cap.
cm	in.	Ltr.	oz.
16	6 ¹ / ₂	0,2	6,96
			06.6139.6030

Salzmühle / Pfeffermühle weiß / salt mill / pepper mill white

Höhe	height	
cm	in.	
19	7 ¹ / ₂	06.6708.4500

Salzmühle / Pfeffermühle schwarz / salt mill / pepper mill black

Höhe	height	
cm	in.	
19	7 ¹ / ₂	06.6709.4500

Porzellantasse S (VPE 6 Stk.) / porcelain cup S (unit 6 pcs.)

Höhe	height	Inhalt	cap.
cm	in.	Ltr.	oz.
7,4	3	0,1	3,4
			60.2508.9990

Deckel mit Ausschnitt / lid with cut-out **55.0031.6040**

Espresso-/Mokkalöffel (VPE 12 Stk.) /
demi-tasse spoon (unit 12 pcs.) **54.9901.6040**

* Artikel einzeln bestellen / please order articles separately

Salz-/Pfeffer-Set PURE EXCLUSIV

salt and pepper set
ménagère 3 pièces
servicio condimento
menage

in 2 Holzvarianten. Bestehend aus: Menage klein, Salz- und Pfefferstreuer, Glas S für Saucen, Butter, Senf... /
in 2 wood versions. Consisting of: stand small, salt and pepper shaker, glass S for sauce, butter, mustard...

Cromargan®, Holz dunkel gebeizt, Holz lackiert /
stainless 18/10, wood dark stained, wood lacquered



Menage klein dunkel / stand small dark

Größe	size
cm	in.
20,5 x 6,2 x 3,7	8 x 2 1/2 x 1 1/2

55.0039.6040

Menage klein natur / stand small nature

Größe	size
cm	in.
20,5 x 6,2 x 3,7	8 x 2 1/2 x 1 1/2

55.0039.6140



Salzstreuer / salt shaker

Höhe	height	Ø	Ø
cm	in.	cm	in.
11	4 1/4	4,1	1 1/2

06.6062.6030

Pfefferstreuer / pepper shaker

Höhe	height	Ø	Ø
cm	in.	cm	in.
11	4 1/4	4,1	1 1/2

06.6063.6030

Glas S (VPE 6 Stk.) / glass S (unit 6 pcs.)

Höhe	height	Inhalt	cap.
cm	in.	Ltr.	oz.
7,4	3	0,1	3,4

60.2506.9990

Deckel mit Ausschnitt / lid with cut-out

55.0031.6040

Espresso-/Mokkalöffel (VPE 12 Stk.) /
demi-tasse spoon (unit 12 pcs.)

54.9901.6040

* Artikel einzeln bestellen / please order articles separately



**Asia-Set
PURE EXCLUSIV**

Asia set
kit ASIA
juego ASIA
set ASIA

in 2 Holzvarianten. Bestehend aus: Menage klein, Essig- und Sojaflasche klein PURE, Glas S für Saucen, Butter, Senf... /
in 2 wood versions. Consisting of: menage small, vinegar and soy bottle small PURE, glass S for sauce, butter, mustard...

Cromargan®, Holz dunkel gebeizt, Holz lackiert /
stainless 18/10, wood dark stained, wood lacquered

Menage klein dunkel / stand small dark

Größe	size	
cm	in.	
20,5 x 6,2 x 3,7	8 x 2 1/2 x 1 1/2	55.0039.6040

Menage klein natur / stand small nature

Größe	size	
cm	in.	
20,5 x 6,2 x 3,7	8 x 2 1/2 x 1 1/2	55.0039.6140

Essig-/Ölflasche, klein / oil and vinegar bottle

Höhe	height	Ø	Ø	
cm	in.	cm	in.	
13	5	4,1	1 1/2	55.0098.6040

Glas S (VPE 6 Stk.) / glass S (unit 6 pcs.)

Höhe	height	Inhalt	cap.	
cm	in.	Ltr.	oz.	
7,4	3	0,1	3,4	60.2506.9990

Deckel mit Ausschnitt / lid with cut-out

55.0031.6040

Espresso-/Mokkalöffel (VPE 12 Stk.) /
demi-tasse spoon (unit 12 pcs.)

54.9901.6040

* Artikel einzeln bestellen / please order articles separately

Menage PURE EXCLUSIV

menage
menagère, à tapenades
set 3 recipientes
ménage per tapenade

in 2 Holzvarianten. Für Tapenade, Fleur de Sel oder Saucen und Dips /
in 2 wood versions. For tapenade, fleur de sel or dips

Cromargan®, Holz dunkel gebeizt, Holz lackiert /
stainless 18/10, wood dark stained, wood lacquered



Menage klein dunkel / stand small dark

Größe	size	
cm	in.	
20,5 x 6,2 x 3,7	8 x 2 1/2 x 1 1/2	55.0039.6040

Menage klein natur / stand small nature

Größe	size	
cm	in.	
20,5 x 6,2 x 3,7	8 x 2 1/2 x 1 1/2	55.0039.6140

Porzellanschälchen (VPE 6 Stk.) / porcelain bowl (unit 6 pcs.)

Höhe	height	Inhalt	cap.	Ø	Ø	
cm	in.	Ltr.	oz.	cm	in.	
4	1 1/2	0,04	1,4	5	2	55.0093.9990



Gewürzlöffel (VPE 12 Stk.) / spicy spoon (unit 12 pcs.)

Länge	length	
cm	in.	
7	2 3/4	54.9184.6040

* Artikel einzeln bestellen / please order articles separately

Essig-/Ölgestell PURE

oil and vinegar set
huilier-vinaigrier
vinagreras
oliera

Cromargan®, Kappen mattiert, Glas /
stainless 18/10, tops satin finished, glass

Höhe	height	
cm	in.	
21	8 1/4	06.1905.6040



Ersatzteil / spare part:

einzelne Flasche komplett / spare bottle complete	06.6139.6030
Ersatzflasche / spare bottle	60.8254.9960
Ausgießer / pouring stopper	60.8255.9990

Zahnstocher- und Süßstoffbehälter PURE

toothpick- and sweetener box-holder
porte-cure-dents et récipient pour sucrettes
palillero y dispensador de edulcorante
porta stuzzicadenti e contenitore per dolcificante

zum Einhängen in alle WMF PURE-Gestelle mit Bügelgriff.

Laser-Gravur der Tischnummer nach Wunsch - Preis auf Anfrage /
fitting in all racks of WMF PURE sets. Engraving of the table No. on
request - please ask for respective costs

Cromargan® / stainless 18/10

Höhe	height	
cm	in.	
4	1 1/2	06.1905.6044





**Senftopf
CLASSIC**

mustard pot
moutardier
mostacero
senapiera

Cromargan® / stainless 18/10

Höhe	height
cm	in.
9	3 1/2

06.6965.6040

Ersatzteil / spare part:
Ersatzglas / spare glass

19.9999.8639



**Käsedose
CLASSIC**

parmesan jar
fromagère
recipiente
formaggiera

mit Kristalleinsatz /
with crystal insert

Cromargan® / stainless 18/10

Ø	Ø
cm	in.
15,5	6

06.2885.6040

Ersatzteil / spare part:
Ersatzglas / spare glass

19.9999.8637



**Käsedose
NEUTRAL**

parmesan jar
fromagère
recipiente
formaggiera

mit Kristalleinsatz /
with crystal insert

Cromargan® / stainless 18/10

Ø	Ø
cm	in.
14,5	5 3/4

06.2868.6040

Ersatzteil / spare part:
Ersatzglas / spare glass
Deckel / cover
Unterteller / underliner

60.8025.9990

06.2868.6042

06.1089.6043



WMF firstglass.
Macht den Genuss klar.

WMF firstglass.
Makes enjoyment crystal clear.

Das Wesen einer Tafel steht und fällt mit formvollendeten Gläsern. Sie schaffen Berührungspunkte und verbinden die Momente geselligen Beisammenseins. Klarheit, Qualität und feinste Verarbeitung umrahmen den Genuss. Und bringen ihn bereits vor dem ersten Schluck glänzend zur Geltung.

Dabei hat jedes Glas seine besondere Funktion. Elegante Tulpenformen unterstützen ein klangvolles Aufperlen. Dickbauchige Kelche geben dem Wein viel Luft für seine volle Entfaltung. Eine gute Ausstattung muss nicht besonders groß sein. Wir beraten Sie gerne bei der richtigen Glasauslese.

Entdecken Sie unsere Glaskollektionen DIVINE, ROYAL, MANHATTAN, SMART unter wmf-professional.de oder in unserer WMF firstglass Broschüre.

Perfectly formed glasses are essential to every table cover. They create points of contact and link the high points of social gatherings. Clarity, quality and superb workmanship capture the spirit of excellence and show it to keen advantage by enhancing the pleasure of that first sip. Each glass has a unique function.

Elegant tulip shapes add tone to beading. Swelling goblets allow the wine plenty of air to breathe. Good equipment does not have to be particularly extensive – we'll be happy to advise you on the right choice of glassware.

Discover our glass collections DIVINE, ROYAL, MANHATTAN, SMART and visit wmf-professional.de or check out our WMF firstglass brochure.



Vielseitige Produkte. Für einen angenehmen Aufenthalt.

Versatile products.
For an enjoyable stay.

Küche, Hotel, Apartment – Servieren Sie Ihren Gästen gutes Design und vielseitige Funktionalität: Servierwagen, die sich in Käsewagen verwandeln, hochwertige robuste Pfannen, Töpfe sowie weiteres Profi-Zubehör für Ihre Küche. Für den angenehmen Aufenthalt Ihrer Gäste bieten wir Basisprodukte für die Zimmerausstattung, die mit minimalen Mitteln maximale Strukturen schaffen. Unsere sinnvoll aufeinander abgestimmten Artikel lassen sich stilvoll und vielseitig in jedes Interieur integrieren. Und sie erklären sich von selbst. Denn funktionales ästhetisches Design ist eine international verständliche Sprache. Begrüßen Sie Ihre Gäste mit dem einladenden Gefühl von angenehmem Komfort und vertrauter Qualität. Unser umfangreiches Sortiment finden Sie unter wmf-professional.de.



Kitchen, hotel, apartment – serve your guests good design and versatile functionality. Serving trolleys that turn into cheese trolleys in seconds; high-quality, robust frying pans, pots and other professional-grade accessories for your kitchen. To ensure that your guests will enjoy every minute of their stay, we offer roomware basic products that maximise structuring with minimal outlay. The items in our range are neatly matched and integrate seamlessly and stylishly with every interior. They are uncomplicated and self-explanatory, because functional aesthetic design is an international language. Welcome your guests with the inviting appeal of pleasurable comfort and trusted quality. Visit wmf-professional.de to view our extensive range.

Buffet

buffet





W

Buffet in Ihrem Takt. WMF Quadro. Das neue Buffet-System.

Buffet to your own beat.
WMF Quadro. The new buffet system.

Alles im GN-Format. Für unbegrenzte Möglichkeiten. Kein Buffet gleicht dem anderen. Darum denkt WMF Quadro das Buffet neu. Der Schlüssel zur Individualität liegt im durchgängigen Umsetzen der GN-Norm: Alles wird möglich, denn alle Elemente sind gleich funktional. Gleich intuitiv. Gleich modular. Das eröffnet neue Freiheiten: für Ihr System. Ihren Takt. Und Ihre eigene, unverwechselbare Gesamtkomposition.

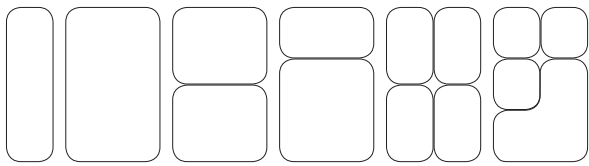

Buffet bedeutet: punktgenaue Taktung. Mit passgenauen Übergängen. Präzise Ablauforganisation. Maximale Synchronisation im perfekt eingespielten Rhythmus. WMF Quadro greift diesen Rhythmus auf. Und bereitet Ihrer Küche eine modulare, hocheffizient konzipierte Bühne.

Everything in Gastronorm format. For unlimited options. No buffet is the same as another. Which is why WMF Quadro has taken a fresh approach to the buffet. The key to individuality is to consistently implement the Gastronorm standard. Everything becomes possible as all of the parts are just as functional. Just as intuitive. Just as modular. This allows a new freedom for your system. Your beat. And your own incomparable, total composition.



A buffet means a pinpoint cycle. With exact transitions. Precise organisation of the procedures. Maximum synchronisation in a perfectly practised rhythm. WMF Quadro takes up this rhythm. And prepares a modular and highly efficient stage for your kitchen.



Die Einsätze. Aus weißem Porzellan.
20 mm oder 65 mm Höhe. In Holz-
optik, Rauchglas oder Glas satiniert.
Brotkorbeinsatz 80 mm Höhe.
The inserts. Made of white porcelain.
20 or 65 mm high. In a wood look,
grey glass or satin glass.
Bread basket insert 80 mm high.



Die Aufsätze und Konsolen.
Optional. In verschiedenen Größen.
The top frames and consoles.
Optional. In various sizes.

Die Eiswanne.
Optional. 55 mm oder 100 mm Höhe.
The ice pan.
Optional. 55 or 100 mm high.

Der Adapterrahmen. Aus Metall.
Optional als LEDlight Einheit aus
mattem Plexiglas.
The adapter frame. Made of metal.
Optionally as LEDlight unit made of
matt acrylic glass.



Die Rahmen. Aus Edelstahl.
80 mm oder 130 mm Höhe.
The frames. Made of stainless
steel. 80 or 130 mm high.

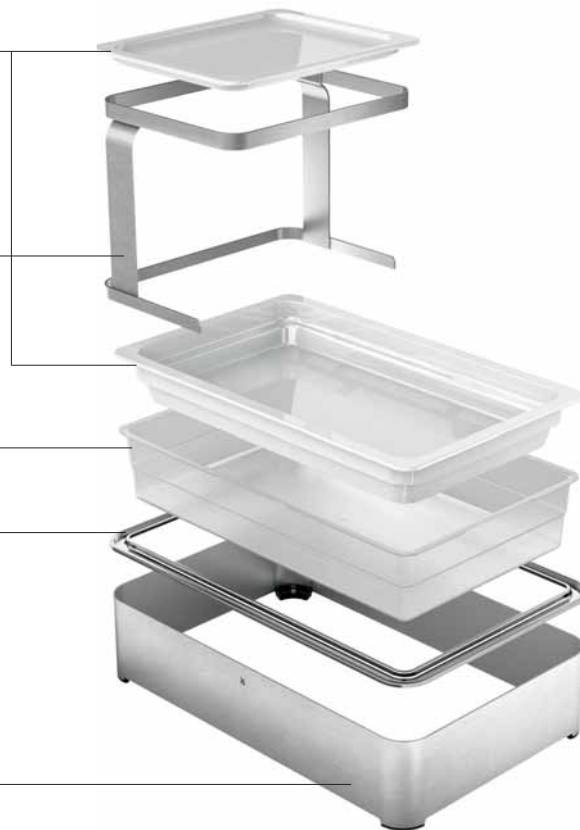

Ob Frühstücks-, Mittags-, Dessert- oder
Abendbuffet: WMF Quadro macht den
Aufbau besonders leicht. Einzelmodule
und Kombinationen sind mit wenigen
Handgriffen einsatzbereit und sofort
reproduzierbar.

Whether a breakfast, midday, dessert or
evening buffet, WMF Quadro makes it
particularly easy to set up. It takes just
a few touches to get single modules and
combinations ready for use and this can
immediately be reproduced.



Direkt zur eigenen Buffet-Bühne. Mit dem WMF Buffet Konfigurator.
Straight to your own buffet stage. With the WMF Buffet configurator.

WMF Quadro macht alles einfacher. Auch
das Kennenlernen: Ihr WMF Partner hat den
WMF Buffet Konfigurator mobil im Einsatz
und bringt ihn zum Beratungsgespräch bei
Ihnen vor Ort mit.

Der Rest geht schnell: Ihre Tischgröße und
Form definieren, 3-D-Buffet-Elemente fest-
legen, nach Ihrem Wunsch kombinieren und
ändern, exportieren – fertig.

WMF Quadro makes it all easier. Even
getting to know it. Your WMF partner has
a mobile version of the WMF buffet config-
urator and will bring it along to offer you
advice on your premises.

The rest is really quick. Define the size and
shape of your tables, specify the 3D modules
for your buffet, combine and change them
as you wish, export – done.

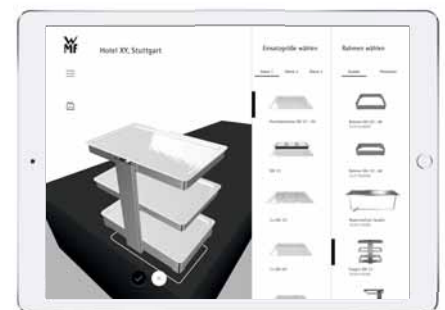



Peter Ramminger.
Design für Ihren Takt.
Ein Blick hinter die Kulissen.

Peter Ramminger.
Design to your own beat.
A glimpse behind the scenes.

Peter Ramminger bringt Erfahrung aus 17 Jahren Designgeschichte mit. Bereits seit seiner Ausbildung zum Stahlgraveur ist er bei der WMF Group tätig, seit 1999 interner Designer und seit 2007 Designmanager für Table Top- und Buffet-Kollektionen bei der proHeq GmbH. Während seiner bisherigen Karriere begleitete er die Entwicklung hunderter Einzelprodukte und Kollektionen – von der ersten Skizze bis zum Einsatz auf Tisch und Tafel. Dabei lautet sein Credo: „Form follows function war gestern. Gutes Design ist selbsterklärend, emotional, funktional und qualitativ langlebig.“

Peter Rammingers jüngste Kreation ist das Zusammenspiel genau dieser Eigenschaften: Das neue Buffet-System WMF Quadro. „Emotionen waren für mich und meine Kollegen ein entscheidender Faktor während des Produktdesigns, um das System aus der funktionalen Nüchternheit zu befreien. Das ist uns durch die natürliche Oberflächentextur mit den Materialien Holz und Glas in Kombination mit der Eleganz des geschliffenen Edelstahls und wertigem Porzellan als Akzent gelungen. Eine geometrische Grundform mit weichen Radien ist die Essenz dieser Formensprache und wird von einer LED-Beleuchtung betont.“ Gleichzeitig erfüllt WMF Quadro die fundamentalen Anforderungen an ein professionelles Buffet-System: Funktionalität und Flexibilität – vom Kühlen über das Stapeln und Kombinieren bis hin zum Anrichten auf mehreren Ebenen.

Fragt man Peter Ramminger nach Design-Trends, zeichnet sich seiner Meinung nach eine technologische und emotionale Ausrichtung ab. „Die Digitalisierung verstärkt auch in unserer Branche den Kundenwunsch nach intelligenten Produkten, transparenten Informationen und nachhaltigen Prozessen. Den emotionalen Gegenpol dazu erzeugen natürliche Oberflächen, Texturen, Farben und Materialien.“



Peter Ramminger has worked in the world of design for 17 years. He first began working at WMF Group since training to become a steel engraver, before taking on the role of Internal Designer in 1999 followed by becoming Design Manager for table top and buffet collections at proHeq GmbH in 2007. Throughout his career he has also assisted with the development of hundreds of individual products and collections – from the initial sketch of the products to seeing them used at the table. His motto is: „Form follows function is a thing of the past. A good design is self-explanatory, emotional, functional and qualitatively long-lasting.“

Peter Ramminger's latest creation is a precise interplay of these properties: The new buffet system WMF Quadro. „Emotions were a decisive factor for my colleagues and I during the product design stage, we wanted to free the system from functional austerity. We were able to achieve this through the natural surface texture using wood and glass, combined with the elegance of grinded stainless steel and high-quality porcelain. A basic geometric shape with gentle radii is the essence of this formal language and is emphasised by an LED light.“ At the same time, WMF Quadro meets the fundamental requirements of a professional buffet system: Functionality and flexibility – from cooling through to stacking and combining as well as serving on several levels.

If you ask Peter Ramminger about design trends, he will tell you that a technological and emotional focus is emerging. „In our sector as well, digitalisation is increasing in our customers' demand for intelligent products, transparent information and sustainable processes. Natural surfaces, textures, colors and materials form an emotional contrast to this.“



**Rahmen GN 1/1**

Frame GN 1/1

Cadre GN 1/1

Marco GN 1/1

Telaio GN 1/1

stapelbar, für GN Einsätze, nur in Verbindung mit Adapter 55.0164.6040 oder 55.0211.9900 /

stackable, for inserts GN, only in combination with adapter 55.0164.6040 or 55.0211.9900

Cromargan®, geschliffen / stainless 18/10, grinded

Maße cm	measures in.	Höhe cm	height in.	
56,2 x 35,7	22 1/4 x 14 1/2	8	3 1/8	55.0140.6090
56,2 x 35,7	22 1/4 x 14 1/2	13	5 1/8	55.0141.6090

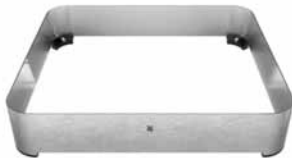
**Rahmen GN 2/3**

Frame GN 2/3

Cadre GN 2/3

Marco GN 2/3

Telaio GN 2/3

stapelbar, für GN Einsätze, nur in Verbindung mit Adapter 55.0165.6040 oder 55.0212.9900 /

stackable, for inserts GN, only in combination with adapter 55.0165.6040 or 55.0212.9900

Cromargan®, geschliffen / stainless 18/10, grinded

Maße cm	measures in.	Höhe cm	height in.	
38,6 x 35,7	15 x 14 1/2	8	3 1/8	55.0142.6090
38,6 x 35,7	15 x 14 1/2	13	5 1/8	55.0143.6090

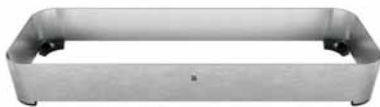
**Rahmen GN 2/4**

Frame GN 2/4

Cadre GN 2/4

Marco GN 2/4

Telaio GN 2/4

stapelbar, für GN Einsätze, nur in Verbindung mit Adapter 55.0166.6040 oder 55.0213.9900 /

stackable, for inserts GN, only in combination with adapter 55.0166.6040 or 55.0213.9900

Cromargan®, geschliffen / stainless 18/10, grinded

Maße cm	measures in.	Höhe cm	height in.	
56,2 x 19	22 1/4 x 7	8	3 1/8	55.0144.6090
56,2 x 19	22 1/4 x 7	13	5 1/8	55.0145.6090

**Rahmen GN 1/3**

Frame GN 1/3

Cadre GN 1/3

Marco GN 1/3

Telaio GN 1/3

stapelbar, für GN Einsätze, nur in Verbindung mit Adapter 55.0167.6040 oder 55.0214.9900 /

stackable, for inserts GN, only in combination with adapter 55.0167.6040 or 55.0214.9900

Cromargan®, geschliffen / stainless 18/10, grinded

Maße cm	measures in.	Höhe cm	height in.	
20,8 x 35,7	8 7/8 x 14 1/2	8	3 1/8	55.0146.6090
20,8 x 35,7	8 7/8 x 14 1/2	13	5 1/8	55.0147.6090



Adapter GN 1/1

Adapter GN 1/1
 Adaptateur GN 1/1
 Adaptador GN 1/1
 Adattatore GN 1/1

für Rahmen GN 1/1 55.0140.6090 und 55.0141.6090 /
 for frame GN 1/1 55.0140.6090 and 55.0141.6090

Cromargan®, poliert / stainless 18/10, mirror finish

Maße	measures	Höhe	height
cm	in.	cm	in.
56,6 x 36,1	22 1/3 x 14 1/5	1	3/8

55.0164.6040



Adapter GN 2/3

Adapter GN 2/3
 Adaptateur GN 2/3
 Adaptador GN 2/3
 Adattatore GN 2/3

für Rahmen GN 2/3 55.0142.6090 und 55.0143.6090 /
 for frame GN 2/3 55.0142.6090 and 55.0143.6090

Cromargan®, poliert / stainless 18/10, mirror finish

Maße	measures	Höhe	height
cm	in.	cm	in.
39 x 36,1	15 3/4 x 14 1/5	1	3/8

55.0165.6040



Adapter GN 2/4

Adapter GN 2/4
 Adaptateur GN 2/4
 Adaptador GN 2/4
 Adattatore GN 2/4

für Rahmen GN 2/4 55.0144.6090 und 55.0145.6090 /
 for frame GN 2/4 55.0144.6090 and 55.0145.6090

Cromargan®, poliert / stainless 18/10, mirror finish

Maße	measures	Höhe	height
cm	in.	cm	in.
56,6 x 19,4	22 1/3 x 7 2/3	1	3/8

55.0166.6040



Adapter GN 1/3

Adapter GN 1/3
 Adaptateur GN 1/3
 Adaptador GN 1/3
 Adattatore GN 1/3

für Rahmen GN 1/3 55.0146.6090 und 55.0147.6090 /
 for frame GN 1/3 55.0146.6090 and 55.0147.6090

Cromargan®, poliert / stainless 18/10, mirror finish

Maße	measures	Höhe	height
cm	in.	cm	in.
21 x 36,2	8 1/4 x 14 1/4	1	3/8

55.0167.6040



Eiswanne GN 1/1

Ice pan GN 1/1
 Bac à glace GN 1/1
 Coche hielo GN 1/1
 Vasca ghiaccio GN 1/1

spülmaschinengeeignet /
 dishwasher-safe

Kunststoff PMMA, transparent / plastic PMMA, transparent

Maße cm	measures in.	Höhe cm	height in.	
51,9 x 31,4	20 1/4 x 12 5/8	5,5	2 1/8	55.0152.9900
51,9 x 31,4	20 1/4 x 12 5/8	10	4	55.0153.9900



Eiswanne GN 2/3

Ice pan GN 2/3
 Bac à glace GN 2/3
 Coche hielo GN 2/3
 Vasca ghiaccio GN 2/3

spülmaschinengeeignet /
 dishwasher-safe

Kunststoff PMMA, transparent / plastic PMMA, transparent

Maße cm	measures in.	Höhe cm	height in.	
34,3 x 31,4	13 x 12 5/8	5,5	2 1/8	55.0154.9900
34,3 x 31,4	13 x 12 5/8	10	4	55.0155.9900



Eiswanne GN 2/4

Ice pan GN 2/4
 Bac à glace GN 2/4
 Coche hielo GN 2/4
 Vasca ghiaccio GN 2/4

spülmaschinengeeignet /
 dishwasher-safe

Kunststoff PMMA, transparent / plastic PMMA, transparent

Maße cm	measures in.	Höhe cm	height in.	
51,9 x 15,1	20 x 5 1/2	5,5	2 1/8	55.0156.9900
51,9 x 15,1	20 x 5 1/2	10	4	55.0157.9900



Eiswanne GN 1/3

Ice pan GN 1/3
 Bac à glace GN 1/3
 Coche hielo GN 1/3
 Vasca ghiaccio GN 1/3

spülmaschinengeeignet /
 dishwasher-safe

Kunststoff PMMA, transparent / plastic PMMA, transparent

Maße cm	measures in.	Höhe cm	height in.	
31,4 x 16,5	12 5/8 x 6	5,5	2 1/8	55.0158.9900
31,4 x 16,5	12 5/8 x 6	10	4	55.0159.9900



Konsole GN $\frac{3}{6}$

console GN $\frac{3}{6}$
 Console GN $\frac{3}{6}$
 Consola GN $\frac{3}{6}$
 Mensola GN $\frac{3}{6}$

stapelbar /
 stackable

Cromargan®, geschliffen / stainless 18/10, grinded

Maße cm	measures in.	Höhe cm	height in.
35 (17) x 32 (16)	14 (7) x 13 (6)	5,2	2

55.0170.6090

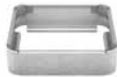

Konsole GN $\frac{1}{6}$

console GN $\frac{1}{6}$
 Console GN $\frac{1}{6}$
 Consola GN $\frac{1}{6}$
 Mensola GN $\frac{1}{6}$

stapelbar /
 stackable

Cromargan®, geschliffen / stainless 18/10, grinded

Maße cm	measures in.	Höhe cm	height in.
17,2 x 15,9	6 $\frac{3}{4}$ x 6 $\frac{1}{4}$	5,2	2

55.0171.6090



Konsole GN $\frac{1}{6}$ mit Fuß

console GN $\frac{1}{6}$ with feet
 Console GN $\frac{1}{6}$ avec pied
 Consola GN $\frac{1}{6}$ con pie
 Mensola GN $\frac{1}{6}$ con piede

stapelbar /
 stackable

Cromargan®, geschliffen / stainless 18/10, grinded

Maße cm	measures in.	Höhe cm	height in.
17,2 x 15,9	6 $\frac{3}{4}$ x 6 $\frac{1}{4}$	9,7	3 $\frac{7}{8}$

55.0173.6090



Konsole GN $\frac{1}{3}$

console GN $\frac{1}{3}$
 Console GN $\frac{1}{3}$
 Consola GN $\frac{1}{3}$
 Mensola GN $\frac{1}{3}$

stapelbar /
 stackable

Cromargan®, geschliffen / stainless 18/10, grinded

Maße cm	measures in.	Höhe cm	height in.
17,2 x 32,1	6 $\frac{3}{4}$ x 12 $\frac{5}{8}$	5,2	2

55.0172.6090



Konsole GN 2/4

console GN 2/4
 Console GN 2/4
 Consola GN 2/4
 Mensola GN 2/4

stapelbar /
 stackable

Cromargan®, geschliffen / stainless 18/10, grinded

Maße	measures	Höhe	height	
cm	in.	cm	in.	
52,5 x 15,6	20 5/8 x 6 1/8	5,2	2	55.0174.6090



Brottschneidebrett GN 1/1

Bread cutting board GN 1/1
 Planche à pain GN 1/1
 Tabla de cortar pan GN 1/1
 Tagliere per pane GN 1/1

Holz Eiche / wood oak

Maße	measures	Höhe	height	
cm	in.	cm	in.	
53 x 32,5	21 x 13	1,9	3/4	55.0198.9900



Platte GN 1/1

Plate GN 1/1
 Plaque GN 1/1
 Plato GN 1/1
 Piatto GN 1/1

	Maße	measures	Höhe	height	
	cm	in.	cm	in.	
Rauchglas einseitig mit Struktur	53,0 x 32,5	21 x 13	0,5	1/4	55.0175.9900
Melamin > Holzoptik Eiche	53,0 x 32,5	21 x 13	0,5	1/4	55.0176.9900
Glas transparent einseitig satiniert	53,0 x 32,5	21 x 13	0,5	1/4	55.0177.9900



Platte GN ²/₃

Plate GN ²/₃

Plaque GN ²/₃

Plato GN ²/₃

Piatto GN ²/₃



	Maße cm	measures in.	Höhe cm	height in.	
Rauchglas einseitig mit Struktur	35,4 x 32,5	14 x 13	0,5	¹ / ₄	55.0178.9900
Melamin > Holzoptik Eiche	35,4 x 32,5	14 x 13	0,5	¹ / ₄	55.0179.9900
Glas transparent einseitig satiniert	35,4 x 32,5	14 x 13	0,5	¹ / ₄	55.0180.9900



Platte GN ²/₄

Plate GN ²/₄

Plaque GN ²/₄

Plato GN ²/₄

Piatto GN ²/₄



	Maße cm	measures in.	Höhe cm	height in.	
Rauchglas einseitig mit Struktur	53,0 x 16,2	21 x 6 ² / ₃	0,5	¹ / ₄	55.0181.9900
Melamin > Holzoptik Eiche	53,0 x 16,2	21 x 6 ² / ₃	0,5	¹ / ₄	55.0182.9900
Glas transparent einseitig satiniert	53,0 x 16,2	21 x 6 ² / ₃	0,5	¹ / ₄	55.0183.9900



Platte GN 1/3

Plate GN 1/3

Plaque GN 1/3

Plato GN 1/3

Piatto GN 1/3



	Maße cm	measures in.	Höhe cm	height in.	
Rauchglas einseitig mit Struktur	17,6 x 32,5	7 x 13	0,5	1/4	55.0184.9900
Melamin > Holzoptik Eiche	17,6 x 32,5	7 x 13	0,5	1/4	55.0185.9900
Glas transparent einseitig satiniert	17,6 x 32,5	7 x 13	0,5	1/4	55.0186.9900



Platte GN 3/6

Plate GN 3/6

Plaque GN 3/6

Plato GN 3/6

Piatto GN 3/6



	Maße cm	measures in.	Höhe cm	height in.	
Rauchglas einseitig mit Struktur	35 (17) x 32 (16)	14 (7) x 13 (7)	0,5	1/4	55.0193.9900
Melamin > Holzoptik Eiche	35 (17) x 32 (16)	14 (7) x 13 (7)	0,5	1/4	55.0194.9900
Glas transparent einseitig satiniert	35 (17) x 32 (16)	14 (7) x 13 (7)	0,5	1/4	55.0195.9900





Brotkorb GN 1/1

Bread basket GN 1/1
 Corbeille à pain GN 1/1
 Panera GN 1/1
 Cestino portapane GN 1/1

spülmaschinengeeignet /
 dishwasher-safe

Kunststoffgeflecht PP / plastic meshwork PP

Maße	measures	Höhe	height	
cm	in.	cm	in.	
53 x 32,5	21 x 13	8	3 1/8	55.0202.9900



Brotkorb GN 2/3

Bread basket GN 2/3
 Corbeille à pain GN 2/3
 Panera GN 2/3
 Cestino portapane GN 2/3

spülmaschinengeeignet /
 dishwasher-safe

Kunststoffgeflecht PP / plastic meshwork PP

Maße	measures	Höhe	height	
cm	in.	cm	in.	
35,4 x 32,5	14 x 13	8	3 1/8	55.0203.9900



Brotkorb GN 2/4

Bread basket GN 2/4
 Corbeille à pain GN 2/4
 Panera GN 2/4
 Cestino portapane GN 2/4

spülmaschinengeeignet /
 dishwasher-safe

Kunststoffgeflecht PP / plastic meshwork PP

Maße	measures	Höhe	height	
cm	in.	cm	in.	
53 x 16,2	21 x 6 2/3	8	3 1/8	55.0204.9900



Brotkorb GN 1/3

Bread basket GN 1/3
 Corbeille à pain GN 1/3
 Panera GN 1/3
 Cestino portapane GN 1/3

spülmaschinengeeignet /
 dishwasher-safe

Kunststoffgeflecht PP / plastic meshwork PP

Maße	measures	Höhe	height	
cm	in.	cm	in.	
17,6 x 32,5	7 x 13	8	3 1/8	55.0205.9900



Brotkorb GN 1/2

Bread basket GN 1/2
 Corbeille à pain GN 1/2
 Panera GN 1/2
 Cestino portapane GN 1/2

spülmaschinengeeignet /
 dishwasher-safe

Kunststoffgeflecht PP / plastic meshwork PP

Maße cm	measures in.	Höhe cm	height in.	
26,5 x 32,5	7 x 13	8	3 1/8	55.0209.9900



Aufsatz GN 1/2 auf GN 1/1, 2/3

top frame GN 1/2 on GN 1/1, 2/3
 Corniche GN 1/2 sur GN 1/1, 2/3
 Suplemento GN 1/2 a GN 1/1, 2/3
 Accessorio GN 1/2 su GN 1/1, 2/3

Cromargan®, geschliffen / stainless 18/10, grinded

Maße cm	measures in.	Höhe cm	height in.	
34,1 x 25	13 1/2 x 9 7/8	25	9 7/8	55.0206.6090



Aufsatz GN 1/3 auf GN 1/1, 2/3, 1/3

top frame GN 1/3 on GN 1/1, 2/3, 1/3
 Corniche GN 1/3 sur GN 1/1, 2/3, 1/3
 Suplemento GN 1/3 a GN 1/1, 2/3, 1/3
 Accessorio GN 1/3 su GN 1/1, 2/3, 1/3

Cromargan®, geschliffen / stainless 18/10, grinded

Maße cm	measures in.	Höhe cm	height in.	
34,1 x 16,1	13 1/2 x 9 7/8	17	6 3/4	55.0207.6090

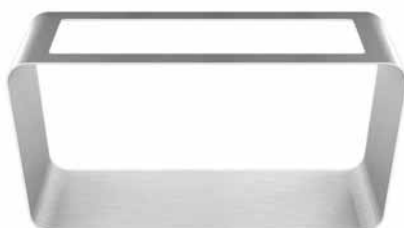

Brücke GN 2/4

Bridge GN 2/4
 Pont GN 2/4
 Puente GN 2/4
 Ponte GN 2/4

Cromargan®, geschliffen / stainless 18/10, grinded

Maße cm	measures in.	Höhe cm	height in.	
64 x 20	25 x 8	30,8	12 1/8	55.0208.6090



Etagere GN 1/1

Serving stand GN 1/1

Etagère GN 1/1

Etageré GN 1/1

Alzata GN 1/1

Cromargan®, geschliffen / stainless 18/10, grinded

Maße	measures	Höhe	height
cm	in.	cm	in.
51,7 x 36	20 1/2 x 14 1/4	50	19 3/4

55.0210.6090



LEDlight Einheit

LEDlight unit

Unitéampoule LED

LEDluz unidad

LEDlight Unità

mit Fernbedienung, Akku und Ladeeinheit, div. Lichtfarben einstellbar, dimmbar /

with remote control, battery and charging unit, various light colors adjustable, dimmable

Kunststoff transluzent / translucent plastic

Maße	measures	Höhe	height
cm	in.	cm	in.
Ø 9,3	Ø 3 5/8	2,6	1

55.0230.9900



LEDlight Adapter GN 1/1

LEDlight adapter GN 1/1

Adaptateurampoule LED GN 1/1

LEDluz Adaptador GN 1/1

LEDlight Adattatore GN 1/1

für Rahmen GN 55.0140.6090 und 55.0141.6090 /
for frame GN 55.0140.6090 and 55.0141.6090

Kunststoff transluzent / translucent plastic

Maße	measures	Höhe	height
cm	in.	cm	in.
56,5 x 36,1	22 1/4 x 14 1/4	1,5	5/8

55.0211.9900



LEDlight Adapter GN 2/3

LEDlight adapter GN 2/3

Adaptateurampoule LED GN 2/3

LEDluz Adaptador GN 2/3

LEDlight Adattatore GN 2/3

für Rahmen GN 55.0142.6090 und 55.0143.6090 /
for frame GN 55.0142.6090 and 55.0143.6090

Kunststoff transluzent / translucent plastic

Maße	measures	Höhe	height
cm	in.	cm	in.
39 x 36,1	15 1/3 x 14 1/4	1,5	5/8

55.0212.9900



LEDlight Adapter GN 2/4

LEDlight adapter GN 2/4
 AdaptateurampouleLED GN 2/4
 LEDluz Adaptador GN 2/4
 LEDlight Adattatore GN 2/4

für Rahmen GN 55.0144.6090 und 55.0145.6090 /
 for frame GN 55.0144.6090 and 55.0145.6090

Kunststoff transluzent / translucent plastic

Maße	measures	Höhe	height	
cm	in.	cm	in.	
56,5 x 19,6	22 1/4 x 7 3/4	1,5	5/8	55.0213.9900



LEDlight Adapter GN 1/3

LEDlight adapter GN 1/3
 AdaptateurampouleLED GN 1/3
 LEDluz Adaptador GN 1/3
 LEDlight Adattatore GN 1/3

für Rahmen GN 55.0146.6090 und 55.0147.6090 /
 for frame GN 55.0146.6090 and 55.0147.6090

Kunststoff transluzent / translucent plastic

Maße	measures	Höhe	height	
cm	in.	cm	in.	
21,2 x 36,1	8 1/4 x 14 1/4	1,5	5/8	55.0214.9900



Porzellaneinsatz GN 3/6

porcelain insert GN 1/8
 Incrustation porcelaine GN 3/6
 Interior de porcelana GN 3/6
 Inserto porcellana GN 3/6

Größe	size	Höhe	height	
cm	in.	cm	in.	
35 (17) x 32 (16)	14 (7) x 13 (6)	2	3/4	55.0219.9800
35 (17) x 32 (16)	14 (7) x 13 (6)	6,5	2 1/2	55.0220.9800

Weitere Auswahl an Einsätzen auf Seite 224 & 225
 More inserts available on page 224 & 225



Porzellaneinsatz GN 1/6

porcelain insert GN 1/8
 Incrustation porcelaine GN 1/6
 Interior de porcelana GN 1/6
 Inserto porcellana GN 1/6

Größe	size	Höhe	height	
cm	in.	cm	in.	
16,2 x 17,5	6 1/3 x 7	6,5	2 1/2	55.0222.9800

Weitere Auswahl an Einsätzen auf Seite 224 & 225
 More inserts available on page 224 & 225

Porzellaneinsatz GN 1/4

porcelain insert GN 1/4
 Incrustation porcelaine GN 1/4
 Interior de porcelana GN 1/4
 Inserto porcellana GN 1/4

Größe cm	size in.	Höhe cm	height in.
26,5 x 16,2	10 1/2 x 6 2/3	6,5	2 1/2

55.0226.9800



Weitere Auswahl an Einsätzen auf Seite 224 & 225
 More inserts available on page 224 & 225

Hygieneschutz

hygienic cover
 Protection hygiénique
 Protección higiénica
 Protezione igienica

Cromargan®, geschliffen, Kunststoff transparent /
 stainless 18/10, grinded / transparent plastic

Maße cm	measures in.	Höhe cm	height in.
115 x 30,4	45 1/4 x 12	52	20 1/2

55.0227.6090



Beschriftunghalter V1 hinten

Label holder V1 rear
 Support pour inscription V1 arrière
 Soporte para etiqueta V1 parte trasera
 Supporto etichetta V1 posteriore

Kunststoff transparent / transparent plastic

Maße cm	measures in.	Höhe cm	height in.
8 x 4,6	3 1/8 x 1 7/8	1,4	1/2

55.0229.9900



Beschriftunghalter V2 vorne

Label holder V2 front
 Support pour inscription V2 avant
 Soporte para etiqueta V2 parte delantera
 Supporto etichetta V2 anteriore

Kunststoff transparent / transparent plastic

Maße cm	measures in.	Höhe cm	height in.
8 x 4,8	3 1/8 x 1 3/4	1,9	3/4

55.0228.9900



Der neue WMF Chafing Dish HOT & FRESH GN 1/1. Der große Buffet-Hotspot. Mit dem richtigen Durchblick.

The brand new WMF HOT & FRESH chafing dish GN 1/1.
The big player on your buffet. With the good looks to show.



NEU | NEW

Der neue WMF HOT & FRESH GN 1/1 beweist Größe in seiner Kategorie. Er leistet sowohl mit Induktionsheizung als auch auf jeder anderen Standard-Wärmequelle tadellose Arbeit. Mit seinem transparenten Glasdeckel sieht er nicht nur gut aus. Er lässt auch die Speisen bestmöglich im Blick behalten. Hitzebeständige Griffe und gastronomietaugliche Materialien erleichtern die Arbeitsabläufe.

The new WMF HOT & FRESH GN 1/1 works perfectly with induction heating or with any other commonly used heat source. The lid is clear glass, so it doesn't just look good, it allows an excellent view of the food as well. Heat-resistant handles and catering-grade materials help keep workflows progressing smoothly.



Buffetgestellt NEUTRAL
buffet stand NEUTRAL



Buffetgestellt MANHATTAN
buffet stand MANHATTAN



Buffetgestellt BASIC
buffet stand BASIC

Induktion und Intuition.

Ein gekapselter Transtherm®-Boden mit Aluminiumkern, das intelligente Rücklaufsystem für Kondenswasser und ein umfangreiches Zubehör – WMF Chafing Dishes HOT & FRESH zeichnen sich durch ihre besondere Funktionalität und Flexibilität aus. Auf alle Produkte der WMF CHANGE Kollektion abgestimmt, lassen sie sich vielseitig kombinieren.

Induction and intuition.

An encapsulated Transtherm® base with aluminium core, the smart return system for condensation and an extensive choice of accessories – WMF HOT & FRESH chafing dishes are characterised by their superb functionality and versatility. Matched to all the products in the WMF CHANGE collection, they can be combined in lots of different ways.



High End Design made in Germany.

Hochwertige Bremsen sorgen dafür, dass der Lauf des Deckels optimal gedämpft wird. Er lässt sich spielend leicht öffnen, bleibt stufenlos stehen und ist ganz soft wieder verschließbar.

High-end design made in Germany.

High-quality brakes keep the movement of the lid optimally slow. The lid opens at a touch, stays open at any angle, and closes again softly to reseal perfectly.



Immer in passender Form.

Die WMF Chafing Dishes HOT & FRESH gibt es rund und rechteckig in GN 2/3- und GN 1/1-Größe, passend für Einsätze bis zehn Zentimeter Tiefe.

Always in great shape.

WMF HOT & FRESH chafing dishes are available round or rectangular in GN 2/3 and GN 1/1 size, compatible with inserts up to ten cm in depth.



Produktvarianten
Product variants



rund
round



GN 2/3
GN 2/3



GN 1/1
GN 1/1

Ausführungen CHANGE
CHANGE models



HOT & FRESH „BASIC“



HOT & FRESH „MANHATTAN“



HOT & FRESH „PALAST“
(Sonderausführung auf Anfrage.
Special design on request.)

Abbildung Chafing Dishes HOT & FRESH „BASIC“
auf Buffetgestell NEUTRAL.

Illustration HOT & FRESH 'BASIC' chafing dishes on
NEUTRAL buffet stands.

**Chafing Dish, „Basic“, GN 1/1
HOT & FRESH**

Chafing Dish, „Basic“, GN 1/1

passend für Einsätze bis Tiefe 10 cm, induktionsgeeignet, alternativ mit Heizplatte und Brennstoff beheizbar, Glasdeckel mit Bremse abnehmbar, Bügelgriff /

for inserts up to depth 10 cm / 4 in., inductive, electrically and sterno heating possible, glass lid with break removable, bow handle

Cromargan®, Glas / stainless 18/10, glass

Größe	size
cm	in.
58 x 47 x 19	22 3/4 x 18 1/2 x 7 1/2

55.0128.6040



**Chafing Dish, „Manhattan“, GN 1/1
HOT & FRESH**

Chafing Dish, „Manhattan“, GN 1/1

passend für Einsätze bis Tiefe 10 cm, induktionsgeeignet, alternativ mit Heizplatte und Brennstoff beheizbar, Glasdeckel mit Bremse abnehmbar, Griff 4-Kantprofil (matt) /

for inserts up to depth 10 cm / 4 in., inductive, electrically and sterno heating possible, glass lid with break removable, bow handle, stainless steel polished, handle profile 4-cornered (satin finished)

Cromargan®, Glas / stainless 18/10, glass

Größe	size
cm	in.
58 x 47 x 19	22 3/4 x 18 1/2 x 7 1/2

55.0129.6040



**Chafing Dish, „Basic“, rund
HOT & FRESH**

Chafing Dish, „Basic“, round

Chafing Dish, „Basic“, rond

Chafing Dish, „Basic“, redondo

Chafing Dish, „Basic“, rotondo

passend für Einsätze bis Tiefe 10 cm, induktionsgeeignet, alternativ mit Heizplatte und Brennstoff beheizbar, Glasdeckel mit Bremse abnehmbar, Bügelgriff /

fitting for inserts up to depth 10 cm / 4 in., inductive, electrically and sterno heating possible, glass lid with brake removable, bow handle

Cromargan®, Glas / stainless 18/10, glass

Höhe	height	Ø	Ø
cm	in.	cm	in.
19	7 1/2	39	15 1/4

55.0001.6040



**Chafing Dish, „Manhattan“, rund
HOT & FRESH**

Chafing Dish, „Manhattan“, round
Chafing Dish, „Manhattan“, rond
Chafing Dish, „Manhattan“, redondo
Chafing Dish, „Manhattan“, rotondo



passend für Einsätze bis Tiefe 10 cm, induktionsgeeignet, alternativ mit Heizplatte und Brennstoff beheizbar, Glasdeckel mit Bremse abnehmbar, Griff 4-Kantprofil (mattiert) / fitting for inserts up to depth 10 cm / 4 in., inductive, electrically and sterno heating possible, glass lid with brake removable, handle profile 4-cornered (satin finished)

Cromargan®, Glas / stainless 18/10, glass

Höhe	height	Ø	Ø
cm	in.	cm	in.
19	7½	39	15¼

55.0020.6040

**Chafing Dish, „Basic“, GN 2/3
HOT & FRESH**

Chafing Dish, „Basic“, GN 2/3
Chafing Dish, „Basic“, GN 2/3
Chafing Dish, „Basic“, GN 2/3
Chafing Dish, „Basic“, GN 2/3



passend für Einsätze bis Tiefe 10 cm, induktionsgeeignet, alternativ mit Heizplatte und Brennstoff beheizbar, Glasdeckel mit Bremse abnehmbar, Bügelgriff / fitting for inserts up to depth 10 cm / 4 in., inductive, electrically and sterno heating possible, glass lid with brake removable, bow handle

Cromargan®, Glas / stainless 18/10, glass

Größe	size
cm	in.
37 x 45 x 19	14½ x 17¾ x 7½

55.0002.6040

**Chafing Dish, „Manhattan“, GN 2/3
HOT & FRESH**

Chafing Dish, „Manhattan“, GN 2/3
Chafing Dish, „Manhattan“, GN 2/3
Chafing Dish, „Manhattan“, GN 2/3
Chafing Dish, „Manhattan“, GN 2/3



passend für Einsätze bis Tiefe 10 cm, induktionsgeeignet, alternativ mit Heizplatte und Brennstoff beheizbar, Glasdeckel mit Bremse abnehmbar, Griff 4-Kantprofil (mattiert) / fitting for inserts up to depth 10 cm / 4 in., inductive, electrically and sterno heating possible, glass lid with brake removable, handle profile 4-cornered (satin finished)

Cromargan®, Glas / stainless 18/10, glass

Größe	size
cm	in.
37 x 45 x 19	14½ x 17¾ x 7½

55.0021.6040



**Buffetgestell, GN 1/1
HOT & FRESH**

frame, GN 1/1
bati, GN 1/1
soporte buffet, GN 1/1
telaio, GN 1/1

für Heizplatte und Brennstoff, passend zu allen Chafing Dishes GN 2/3
HOT & FRESH /
for electrically and sterno heating, fitting for all chafing dishes GN 2/3
HOT & FRESH

Cromargan®, poliert / stainless 18/10, mirror finish

Größe	size
cm	in.
58 x 37 x 17	22 3/4 x 14 1/2 x 6 3/4

55.0137.6040



**Buffetgestell, „Basic“, GN 1/1
HOT & FRESH**

frame, „Basic“, GN 1/1
bati, „Basic“, GN 1/1
soporte buffet, „Basic“, GN 1/1
telaio, „Basic“, GN 1/1

für Heizplatte und Brennstoff, Füße Rundprofil /
for electrically and sterno heating, feet profile round

Cromargan®, poliert / stainless 18/10, mirror finish

Größe	size
cm	in.
65 x 37 x 24	25 1/2 x 14 1/2 x 9 1/2

55.0130.6040



**Buffetgestell, „Manhattan“, GN 1/1
HOT & FRESH**

frame, „Manhattan“, GN 1/1
bati, „Manhattan“, GN 1/1
soporte buffet, „Manhattan“, GN 1/1
telaio, „Manhattan“, GN 1/1

für Heizplatte und Brennstoff, Füße 4-Kantprofil (mattiert) /
for electrically and sterno heating, feet profile 4-cornered (satin
finished)

Cromargan®, poliert / stainless 18/10, mirror finish

Größe	size
cm	in.
66 x 37 x 24	26 1/2 x 14 1/2 x 9 1/2

55.0131.6040



Buffetgestell, „Basic“, rund
HOT & FRESH

frame, „Basic“, round
bati, „Basic“, rond
soporte buffet, „Basic“, redondo
telaio, „Basic“, rotondo

für Heizplatte und Brennstoff, Füße Rundprofil /
for electrically and sterno heating, feet profile round

Cromargan® / stainless 18/10

Höhe	height	Ø	Ø
cm	in.	cm	in.
24	9½	47	18½

55.0007.6040



Buffetgestell, „Manhattan“, rund
HOT & FRESH

frame, „Manhattan“, round
bati, „Manhattan“, rond
soporte buffet, „Manhattan“, redondo
telaio, „Manhattan“, rotondo

für Heizplatte und Brennstoff, Füße 4-Kantprofil (mattiert) /
for electrically and sterno heating, feet profile 4-cornered (satin finished)

Cromargan® / stainless 18/10

Höhe	height	Ø	Ø
cm	in.	cm	in.
24	9½	47	18½

55.0008.6040



Buffetgestell, „Basic“, GN 2/3
HOT & FRESH

frame, „Basic“, GN 2/3
bati, „Basic“, GN 2/3
soporte buffet, „Basic“, GN 2/3
telaio, „Basic“, GN 2/3

für Heizplatte und Brennstoff, Füße Rundprofil /
for electrically and sterno heating, feet profile round

Cromargan® / stainless 18/10

Größe	size
cm	in.
44 x 40 x 24	17¼ x 15¾ x 9½

55.0012.6040



Buffetgestell, „Manhattan“, GN 2/3

HOT & FRESH

frame, „Manhattan“, GN 2/3

bati, „Manhattan“, GN 2/3

soporte buffet, „Manhattan“, GN 2/3

telaio, „Manhattan“, GN 2/3

für Heizplatte und Brennstoff, Füße 4-Kantprofil (mattiert) /
for electrically and sterno heating, feet profile 4-cornered (satin
finished)

Cromargan® / stainless 18/10

Größe	size
cm	in.
44 x 40 x 24	17 ¹ / ₄ x 15 ³ / ₄ x 9 ¹ / ₂

55.0013.6040



Buffetgestell, rund

HOT & FRESH

frame, round

bati, rond

soporte buffet, redondo

telaio, rotondo

für Heizplatte und Brennstoff, passend zu allen runden Chafing Dishes
HOT & FRESH /

for electrically and sterno heating, fitting for all round chafing dishes
HOT & FRESH

Cromargan® / stainless 18/10

Höhe	height	Ø	Ø
cm	in.	cm	in.
17	6 ³ / ₄	39	15 ¹ / ₄

55.0005.6040



Buffetgestell, GN 2/3

HOT & FRESH

frame, GN 2/3

bati, GN 2/3

soporte buffet, GN 2/3

telaio, GN 2/3

für Heizplatte und Brennstoff, passend zu allen Chafing Dishes GN 2/3
HOT & FRESH /

for electrically and sterno heating, fitting for all chafing dishes GN 2/3
HOT & FRESH

Cromargan® / stainless 18/10

Größe	size
cm	in.
37 x 40 x 17	14 ¹ / ₂ x 15 ³ / ₄ x 6 ³ / ₄

55.0006.6040



Rinderfilet in Rotweinsauce

Suppen mit Meeresfrüchten

WMF CHANGE Chafing Dishes:
Freie Hand am Buffet. Von allen Seiten.

WMF CHANGE chafing dishes:
One hand free at the buffet. From all sides.



Die WMF CHANGE Chafing Dishes gehen Hand in Hand mit einem reibungslosen Ablauf am Buffet, denn sie sind besonders einfach bedienbar, hygienisch und ganzheitlich durchdacht. Ihre Rolltop-Deckel lassen sich nahezu geräuschlos und leicht auf und zu schieben, so dass immer eine Hand für den Teller und die Speisen frei bleibt. Nichts muss umständlich abgestellt oder wieder zugedeckt werden. Das spart Zeit, Energie und hebt die Laune.

The WMF CHANGE chafing dishes go hand in hand with smooth proceedings at the buffet due to being outstandingly user-friendly, hygienic and well-designed. The roll-top lids slide open and closed almost soundlessly and with the easy action that leaves one hand free for plate and goodies. Nothing has to be awkwardly set down or covered over again. This helps save time and energy and lifts the mood.

Einfach und sorglos zu bedienen.

Kein Tropfen, keine Wasserrückstände auf dem Tisch, dafür hitzeisolierte Griffe. Und die Deckel der WMF CHANGE Chafing Dishes mit integriertem Kondenswasserrücklauf sind komplett versenkbar. Sie schwingen außerhalb des Drehpunktes um den Brennstoffdosenhalter oder die Heizplatte vollständig unter den Behälter. So sind die Speisen von allen Seiten zugänglich und die Belüftung der Flamme ist stets gewährleistet.

Handle without care.

No drips, no water marking the table; thermally insulated handles instead. And the lids of the WMF CHANGE chafing dishes with integral condensation return are fully retractable. They swing outside the pivot point round the fuel-can holder or the hotplate and pass completely underneath the containers. So the dishes are accessible from all sides and the flame is never choked for air.

Lässt sich mit Links öffnen.

Ergonomisch durchdacht garantiert eine spezielle Kabelführung auch beim Einsatz eines elektrischen Heizteiles, dass sich der Deckel problemlos öffnen lässt. Leichtgängige, stufenlose Bremsen sorgen dafür, dass der Lauf des Deckels optimal gedämpft wird. Für ein spielend einfaches Öffnen, Schließen und Arretieren. Alle Modelle, außer Manhattan, lassen sich platz sparend stapeln.

Opens at the lightest touch.

A model of ergonomics in practice, a special cable guide allows the lid to open easily even when an electric heating element is in use. Smooth-acting, stepless brakes keep the movement of the lid optimally slow. For totally convenient opening, closing and stopping. All models, except the Manhattan, are stackable to save space.

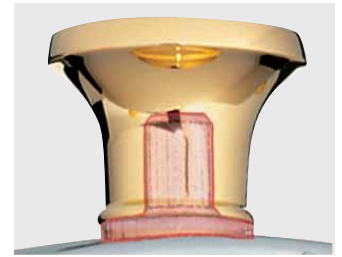

Produktvarianten Product variants



GN 1/1
GN 1/1



rund
round

Ausführungen CHANGE CHANGE models



„BASIC“



„MANHATTAN“



„METROPOLITAIN“





Chafing Dish, "Basic"

CHANGE

Chafing Dish, "Basic"
 Chafing Dish, "Basic"
 Chafing Dish, "Basic"
 Chafing Dish, "Basic"

passend für Einsätze bis Tiefe 10 cm /
 fitting for inserts up to depth 4 in.

GN 1/1, Rolltopdeckel, elektrisch und Brennstoff beheizbar, Deckel versenkbar /

GN 1/1, full rolltop cover, electrically and sterno heated, cover immersible

Cromargan®, Füße Rundprofil, Bügelgriffe /
 stainless 18/10, feet profil round, with bow handles
 ohne Einsätze / w/o inserts

Höhe cm	height in.	Größe mit Griffen cm	size with handles in.
45,6	18	74 x 38	28 1/4 x 15

06.3333.6041

Zubehör / accessory:

Heizelement 230 V / 600 W / heating element 230 V / 600 W	55.0097.6044
Heizelement 120 V / 600 W / heating element 120 V / 600 W	55.0097.9990
Heizelement 230 V / 700 W mit Regler / heating element 230 V / 700 W heat adjustable	06.3286.6046
Brennstoffdosenhalter / burner holder	06.3322.6039



Chafing Dish, "Metropolitan"

CHANGE

Chafing Dish, "Metropolitan"
 Chafing Dish, "Metropolitan"
 Chafing Dish, "Metropolitan"
 Chafing Dish, "Metropolitan"

passend für Einsätze bis Tiefe 10 cm /
 fitting for inserts up to depth 4 in.

GN 1/1, Rolltopdeckel, elektrisch und Brennstoff beheizbar, Deckel versenkbar /

GN 1/1, full rolltop cover, electrically and sterno heated, cover immersible

Cromargan®, Füße Rundprofil, Kugelgriffe /
 stainless 18/10, feet profil round, with knob handles
 ohne Einsätze / w/o inserts

Höhe cm	height in.	Größe mit Griffen cm	size with handles in.
45,6	18	74 x 38	28 1/4 x 15

06.3330.6041

Zubehör / accessory:

Heizelement 230 V / 600 W / heating element 230 V / 600 W	55.0097.6044
Heizelement 120 V / 600 W / heating element 120 V / 600 W	55.0097.9990
Heizelement 230 V / 700 W mit Regler / heating element 230 V / 700 W heat adjustable	06.3286.6046
Brennstoffdosenhalter / burner holder	06.3322.6039

Bitte Heizelement und Brennstoffdosenhalter separat bestellen. Einzelteile (Seite 219) /
 Please order heating elements and burner holder separately. Spare parts (page 219)



Chafing Dish, "Metropolitan", rund CHANGE

Chafing Dish, "Metropolitan", round
Chafing Dish, "Metropolitan", rond
Chafing Dish, "Metropolitan", redondo
Chafing Dish, "Metropolitan", rotondo

passend für Einsätze bis Tiefe 10 cm /
fitting for inserts up to depth 4 in.

rund, Rolltopdeckel, elektrisch und Brennstoff beheizbar, Deckel
versenkbar /
round, full rolltop cover, electrically and sterno heated, cover
immersible

Cromargan®, Füße Rundprofil, Kugelgriff /
stainless 18/10, feet profil round, with knob handle

Höhe cm	height in.	Ø cm	Ø in.	
46	18	43	17	06.3940.6041

Zubehör / accessory:

Heizelement 140-250 V / 270 W / heating element 140-250 V / 270 W	55.0096.6044
Heizelement 100-120 V / 230 W / heating element 100-120 V / 230 W	55.0096.9990
Heizelement 230 V / 550 W mit Regler / heating element 230 V / 550 W heat adjustable	06.2095.6046
Brennstoffdosenhalter / burner holder	06.3940.6039



Chafing Dish, "Manhattan" CHANGE

Chafing Dish, "Manhattan"
Chafing Dish, "Manhattan"
Chafing Dish, "Manhattan"
Chafing Dish, "Manhattan"

passend für Einsätze bis Tiefe 10 cm /
fitting for inserts up to depth 4 in.

GN 1/1, Rolltopdeckel, elektrisch und Brennstoff beheizbar, Deckel
versenkbar /

GN 1/1, full rolltop cover, electrically and sterno heated, cover
immersible

Cromargan®, teilmattiert, Füße und Griffe im 4-Kantprofil /
stainless 18/10, partly satin finished, handles and feet profil 4-cornered
ohne Einsätze / w/o inserts

Höhe cm	height in.	Größe mit Griffen cm	size with handles in.	
45,6	18	74 x 38	28 1/4 x 15	06.3335.6041

Zubehör / accessory:

Heizelement 230 V / 600 W / heating element 230 V / 600 W	55.0097.6044
Heizelement 120 V / 600 W / heating element 120 V / 600 W	55.0097.9990
Heizelement 230 V / 700 W mit Regler / heating element 230 V / 700 W heat adjustable	06.3286.6046
Brennstoffdosenhalter / burner holder	06.3322.6039



**Chafing Dish, "Manhattan", rund
CHANGE**

Chafing Dish, "Manhattan", round
Chafing Dish, "Manhattan", rond
Chafing Dish, "Manhattan", redondo
Chafing Dish, "Manhattan", rotondo

passend für Einsätze bis Tiefe 10 cm /
fitting for inserts up to depth 4 in.

rund, Rolltopdeckel, elektrisch und Brennstoff beheizbar, Deckel
versenkbar /
round, full rolltop cover, electrically and sterno heated, cover
immersible

Cromargan®, teilmattiert, Füße und Griff im 4-Kantprofil /
stainless 18/10, partly satin finished, handle and feet profil 4-cornered

Höhe cm	height in.	Ø cm	Ø in.	
46	18	43	17	06.3945.6041

Zubehör / accessory:

Heizelement 140-250 V / 270 W / heating element 140-250 V / 270 W	55.0096.6044
Heizelement 100-120 V / 230 W / heating element 100-120 V / 230 W	55.0096.9990
Heizelement 230 V / 550 W mit Regler / heating element 230 V / 550 W heat adjustable	06.2095.6046
Brennstoffdosenhalter / burner holder	06.3940.6039



Breite Aufliegerahmen: 35,5 mm
width supporting frame: 1 3/8 in.



**Chafing Dish, Thekeneinbau
STANDARD**

Chafing Dish, to be built into counter
Chafing Dish, pour montage en comptoir
Chafing Dish, encastrado
Chafing Dish, emportable

passend für Einsätze bis Tiefe 10 cm /
fitting for inserts up to depth 4 in.

GN 1/1, Rolltopdeckel, elektrisch beheizbar /
GN 1/1, full rolltop cover, electrically heated

Cromargan® / stainless 18/10
ohne Einsätze / w/o inserts

Höhe cm	height in.	Größe cm	size in.	
17	6 3/4	65 x 47	25 5/8 x 18 1/2	06.3266.6041

Zubehör / accessory:

Heizelement 230 V / 600 W / heating element 230 V / 600 W	55.0097.6044
Heizelement 120 V / 600 W / heating element 120 V / 600 W	55.0097.9990
Heizelement 230 V / 700 W mit Regler / heating element 230 V / 700 W heat adjustable	06.3286.6046

Ausschnittmaße / cut out size



Bitte Heizelement und Brennstoffdosenhalter separat bestellen. Einzelteile (Seite 219) /
Please order heating elements and burner holder separately. Spare parts (page 219)



Portions-Chafing Dish

STANDARD

Chafing Dish, S
Chafing Dish, S
Chafing Dish, S
Chafing Dish, S

passend für alle handelsüblichen Porzellanteller mit \varnothing 23 cm, beheizbar mit Teelichte (nicht enthalten) / suitable for all porcelain plates \varnothing 9 in., heated by tealights (not included)

rund, Rolltopdeckel, mit 2 Teelichten beheizbar / round, full rolltop cover, heated by 2 tealights

Cromargan® / stainless 18/10
ohne Einsätze / w/o inserts

Höhe	height	\varnothing	\varnothing
cm	in.	cm	in.
29	11 1/2	26	10 1/4

06.3306.6040



Breite Aufliegerahmen: 40 mm
width supporting frame: 1 1/2 in.



Chafing Dish, Thekeneinbau

STANDARD

Chafing Dish, to be built into counter
Chafing Dish, pour montage en comptoir
Chafing Dish, encastrado
Chafing Dish, emportable

passend für Einsätze bis Tiefe 10 cm / fitting for inserts up to depth 4 in.

rund, Rolltopdeckel, elektrisch beheizbar / round, full rolltop cover, electrically heated

Cromargan® / stainless 18/10
ohne Hezelement, ohne Einsätze / w/o heating element, w/o inserts

Höhe	height	\varnothing	\varnothing
cm	in.	cm	in.
18,3	7 1/4	48	18 7/8

06.3290.6041

Zubehör / accessory:

Hezelement 140-250 V / 270 W / heating element 140-250 V / 270 W 55.0096.6044

Hezelement 100-120 V / 230 W / heating element 100-120 V / 230 W 55.0096.9990

Hezelement 230 V / 550 W mit Regler / heating element 230 V / 550 W heat adjustable 06.2095.6046

Draufsicht / top view

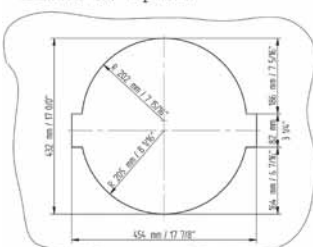

Ausschnittmaße / cut out size

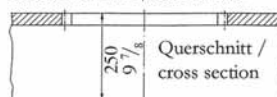



Chafing Dish, mit Domdeckel

ECONOMY

Chafing Dish, conventional standard cover

Chafing Dish, avec couvercle standard

Chafing Dish, tapa estándar

Chafing Dish, con coperchio standard

passend für Einsätze bis Tiefe 10 cm, Deckel zu allen 4 Seiten

hochstellbar /

fitting for inserts up to depth 4 in., lid can be raised on all 4 sides

GN 1/1, stapelbar, Domdeckel, elektrisch und Brennstoff beheizbar /

GN 1/1, stackable, conventional standard cover, electrically and sterno heated

Cromargan® matt / stainless 18/10 satin finished

ohne Einsätze / w/o inserts

Höhe mit Griff	height with handle	Größe mit Griffen	size with handles	
cm	in.	cm	in.	
32	12 1/2	62 x 35	24 1/2 x 13 3/4	06.3322.6230

Zubehör / accessory:

Heizelement 230 V / 600 W / heating element 230 V / 600 W 55.0097.6044

Heizelement 120 V / 600 W / heating element 120 V / 600 W 55.0097.9990

Heizelement 230 V / 700 W mit Regler / heating element 230 V / 700 W heat adjustable 06.3286.6046

Brennstoffdosenhalter / burner holder 06.3322.6039

Heizelement 230 V / 1000 W / heating element 230 V / 1000 W 06.2082.6044

Adapter für Elektroheizteil / holder for heating element 06.3272.6039



Chafing Dish, mit Klappdeckel

ECONOMY

Chafing Dish, 1/2 rolltop cover

Chafing Dish, avec couvercle rabattable

Chafing Dish, con tapa abatible

Chafing Dish, con coperchio ribaltabile

passend für Einsätze bis Tiefe 10 cm /

fitting for inserts up to depth 4 in.

GN 1/1, Klappdeckel, elektrisch und Brennstoff beheizbar /

GN 1/1, cover, electrically and sterno heated

Cromargan® matt / stainless 18/10 satin finished

ohne Einsätze / w/o inserts

Höhe mit Griff	height with handle	Größe mit Griffen	size with handles	
cm	in.	cm	in.	
36	14 1/4	62 x 35	24 1/2 x 13 3/4	06.3324.6230

Zubehör / accessory:

Heizelement 230 V / 600 W / heating element 230 V / 600 W 55.0097.6044

Heizelement 120 V / 600 W / heating element 120 V / 600 W 55.0097.9990

Heizelement 230 V / 700 W mit Regler / heating element 230 V / 700 W heat adjustable 06.3286.6046

Brennstoffdosenhalter / burner holder 06.3322.6039

Heizelement 230 V / 1000 W / heating element 230 V / 1000 W 06.2082.6044

Adapter für Elektroheizteil / holder for heating element 06.3272.6039



Bitte Heizelement und Brennstoffdosenhalter separat bestellen. Einzelteile (Seite 219) / Please order heating elements and burner holder separately. Spare parts (page 219)

Ersatzteile für WMF Chafing Dishes
Spare parts for WMF Chafing Dishes

Bezeichnung Designation	Artikel-Nummer Order no.	Ausführung execution	Cromargan Stainless 18/10	Teilvergoldet partly gold plated	Deckel cover	Wasserbad- wanne water pan	Einbaurahmen frame	Brennstoffhalter burner holder	Heizelement heating element	Heizelement mit Regler heating element adjustable
Thekeneinbau GN 1/1	06.3266.6040	bis/ till 2015	•		06.3330.6042	06.3319.6231	06.3266.6045		55.0097.6044	06.3286.6046
Thekeneinbau GN 1/1	06.3266.6041	Neue Bremse/ New Brakes 2015	•		06.3330.6043		06.3266.6046			
Thekeneinbau, rund	06.3290.6040	bis/ till 2015	•		06.3283.6042	06.2003.6041	06.3290.6045		55.0096.6044	06.2095.6046
Thekeneinbau, rund	06.3290.6041	Neue Bremse/ New Brakes 2015	•		06.3283.6043		06.3290.6046			
Economy GN 1/1	06.3322.6230		•		06.3322.6232	06.3322.6231		06.3322.6039	55.0097.6044	06.3286.6046
Economy GN 1/1	06.3324.6230		•		06.3324.6232			06.3322.6039	55.0097.6044	06.3286.6046
Metropolitan GN 1/1	06.3330.6040	bis/ till 2015	•		06.3330.6042			06.3322.6039	55.0097.6044	06.3286.6046
Metropolitan GN 1/1	06.3330.6041	Neue Bremse/ New Brakes 2015	•		06.3330.6043					
Palast GN 1/1	06.3331.6210	bis/ till 2015		•	06.3331.6212					
Palast GN 1/1	Sonderausführung / special design Auf Anfrage / on request	Neue Bremse/ New Brakes 2015		•	Sonderausführung / special design Auf Anfrage / on request	06.3319.6231		06.3322.6039	55.0097.6044	06.3286.6046
Basic GN 1/1	06.3333.6040	bis/ till 2015	•		06.3333.6042			06.3322.6039	55.0097.6044	06.3286.6046
Basic GN 1/1	06.3333.6041	Neue Bremse/ New Brakes 2015	•		06.3333.6043					
Manhattan GN 1/1	06.3335.6040	bis/ till 2015	•		06.3335.6042				55.0097.6044	06.3286.6046
Manhattan GN 1/1	06.3335.6041	Neue Bremse/ New Brakes 2015	•		06.3335.6043			06.3322.6039	55.0097.6044	06.3286.6046
Metropolitan rund	06.3940.6040	bis/ till 2015	•		06.3940.6042			06.3940.6039	55.0096.6044	06.2095.6046
Metropolitan rund	06.3940.6041	Neue Bremse/ New Brakes 2015	•		06.3940.6043	06.2003.6041				
Palast rund	06.3941.6210	bis/ till 2015		•	06.3941.6212					
Palast rund	Sonderausführung / special design Auf Anfrage / on request	Neue Bremse/ New Brakes 2015		•	Sonderausführung / special design Auf Anfrage / on request	06.2003.6041		06.3940.6039	55.0096.6044	06.2095.6046
Manhattan rund	06.3945.6040	bis/ till 2015	•		06.3945.6042			06.3940.6039	55.0096.6044	06.2095.6046
Manhattan rund	06.3945.6041	Neue Bremse/ New Brakes 2015	•		06.3945.6043					
combiNation Buffet GN 1/1	06.2446.6040		•		06.2446.6042	06.3322.6231			55.0097.6044	06.3286.6046
combiNation Buffet GN 1/1	06.2423.6040		•			06.3322.6231			55.0097.6044	06.3286.6046
combiNation Buffet GN 1/1	06.2442.6040		•			06.3322.6231				

Bitte bestellen Sie die Heizelemente und Brennstoffhalter separat (s. Katalog Chafing Dish-Zubehör) Please order the heating elements and the burner holder separately. (see catalogue Chafing Dish-Accessory)



Suppenmarmite

soup tureen
marmite à potage
recipiente sopa
zuppiera

passend in Chafing Dish GN 1/1 und HOT & FRESH GN 2/3 /
fitting for chafing dish GN 1/1 and HOT & FRESH GN 2/3

Cromargan® / stainless 18/10

Größe	size	Inhalt	cap.
cm	in.	Ltr.	oz.
36 x 33	14 1/4 x 13	4,5	157,5

Topf f. Aufliegedeckel / pot f. normal lid	06.2007.6041
Aufliegedeckel / normal lid	06.2098.6042
Topf f. Scharnierdeckel / pot f. hinged lid	06.2007.9991
Scharnierdeckel / hinged lid	06.2007.9992
Einsatzring / ring	06.3301.6044

* Artikel einzeln bestellen / please order articles separately



Suppenmarmite

soup tureen
marmite à potage
recipiente sopa
zuppiera

passend in Chafing Dish GN 1/1 und HOT & FRESH GN 2/3 /
fitting for chafing dish GN 1/1 and HOT & FRESH GN 2/3

Cromargan® / stainless 18/10

Größe	size	Inhalt	cap.
cm	in.	Ltr.	oz.
36 x 33	14 1/4 x 13	9	315

Topf mit Deckel / pot with cover	06.3297.6040
Einsatzring / ring	06.2094.6044

* Artikel einzeln bestellen / please order articles separately



Suppenstation, GN 1/1 mit Deckel

soup tureen, GN 1/1 with lid
 marmite à potage, GN 1/1 avec couvercle
 recipiente sopa, GN 1/1 con tapa
 zuppiera, GN 1/1 con coperchio

passend in Chafing Dish GN 1/1 /
 fitting for chafing dish GN 1/1

Größe	size	Inhalt	cap.
cm	in.	Ltr.	oz.
53 x 32,5	20 ³ / ₄ x 12 ³ / ₄	2 x 4,5	2 x 157,5

Ausführung I /quality I

Cromargan® / stainless 18/10
 1 Abdeckplatte, 2 Suppentöpfe mit Scharnierdeckel / 1 insert
 plate and 2 soup tureens with hinged lid
 Komplett / complete

06.2007.9990

Ausführung II /quality II

Cromargan® / stainless 18/10
 1 Abdeckplatte und 2 Suppentöpfe mit Deckel / 1 insert plate
 and 2 soup tureens with lid
 Komplett / complete

06.2007.6040

Ersatzteil / spare part:

Topf f. Scharnierdeckel / pot f. hinged lid	06.2007.9991
Topf f. Aufliegedeckel / pot f. normal lid	06.2007.6041
Scharnierdeckel / hinged lid	06.2007.9992
Aufliegedeckel / normal lid	06.2098.6042
Brille / insert holder	06.2098.6044

Suppenmarmite

soup tureen
 marmite à potage
 sopera para chafing dish
 zuppiera per chafing dish

passend in alle großen runden WMF Chafing Dishes und in den Chafing
 Dish HOT & FRESH rund. In 2 Versionen bestellbar: Ring + Topf f.
 Aufliegedeckel + Aufliegedeckel / Ring + Topf für Scharnierdeckel +
 Scharnierdeckel. /
 fitting in all big round WMF chafing dishes and in Chafing Dish HOT
 & FRESH round. To be ordered in 2 versions: ring + pot f. normal lid +
 cover / ring + pot f. hinged lid + hinged cover.

Cromargan® / stainless 18/10

Inhalt	cap.	Ø	Ø
Ltr.	oz.	cm	in.
4,5	157,5	34	13 ¹ / ₂

Ring / ring	55.0068.6040
Topf f. Aufliegedeckel / pot f. normal lid	06.2007.6041
Aufliegedeckel / normal lid	06.2098.6042
Topf f. Scharnierdeckel / pot f. hinged lid	06.2007.9991
Scharnierdeckel / hinged lid	06.2007.9992

* Artikel einzeln bestellen / please order articles separately





Suppenmarmite

soup tureen
marmite à potage
sopera para chafing dish
zuppiera per chafing dish

passend in alle großen runden Chafing Dishes von WMF und den Chafing Dish HOT & FRESH rund / fitting for all big round WMF chafing dishes and in chafing dish HOT & FRESH round

Cromargan® / stainless 18/10

Inhalt	cap.	Ø	Ø
Ltr.	oz.	cm	in.
9	315	34	13 1/2

Topf mit Deckel / pot with cover

06.3297.6040

Ring / ring

06.2087.6044

* Artikel einzeln bestellen / please order articles separately



Einsatz für Chafing Dish

insert for chafing dish
intérieur pour chafing dish
depósito para chafing dish
inserto piatto chafing dish

passend in alle großen runden Chafing Dishes von WMF / fitting for all big round WMF chafing dishes

Cromargan® / stainless 18/10

Höhe	height	Inhalt	cap.	Ø	Ø
cm	in.	Ltr.	oz.	cm	in.
8	3 1/4	5	175	33,4	13 1/4
10,5	4 1/4	6,5	227,5	33,4	13 1/4

06.2083.6034

06.2083.6033



Porzellan-Einsatz, geteilt

porcelain insert, divided
intérieur en porcelaine, divisé
recipiente de porcelana, dividido
interno in porcellana, ripartito

passend in alle großen runden Chafing Dishes von WMF / fitting for all big round WMF chafing dishes

Porzellan / porcelain

Höhe	height	Inhalt	cap.	Ø	Ø
cm	in.	Ltr.	oz.	cm	in.
7	2 3/4	2 x 1,75	2 x 62	33,5	13 1/4

60.3073.9990



Porzellan-Einsatz

porcelain insert
intérieur en porcelaine
interior porcelana
interno in porcellana

passend in alle großen runden Chafing Dishes von WMF /
fitting for all big round WMF chafing dishes

Porzellan / porcelain

Höhe cm	height in.	Inhalt Ltr.	cap. oz.	Ø cm	Ø in.	
7	2 ³ / ₄	3,75	131,3	33,5	13 ¹ / ₄	60.3072.9990



Porzellan-Einsätze

porcelain insert
intérieur en porcelaine
interior de porcelana
interno in porcellana

Porzellan weiß / porcelain white

Inhalt Ltr.	cap. oz.	Ø cm	Ø in.	
1,5	52,5	20	8	60.3004.0690



Platte, rund

platter, round
plat, rond
fuente, redonda
vassoio, rotondo

passend in alle WMF Portions-Chafing Dishes /
fitting for all WMF chafing dishes small size

Cromargan® / stainless 18/10

Ø cm	Ø in.	
23	9	06.3306.6044



Gastronorm-Einsatz, zu Chafing Dish

GN insert, for chafing dish

GN intérieur, pour chafing dish

GN interior, para chafing dish

GN interno, per chafing dish

Edelstahl 18/10 / stainless 18/10

Einsatz GN 1/3 / insert GN 1/3

Größe cm	size in.	Inhalt Ltr.	cap. oz.	
6,5 x 17,5 x 32,5	2 1/2 x 7 x 12 3/4	2,4	84	19.9955.0577
10 x 17,5 x 32,5	4 x 7 x 12 3/4	3,75	133	19.9955.0578

Einsatz GN 1/2 / insert GN 1/2

Größe cm	size in.	Inhalt Ltr.	cap. oz.	
6,5 x 26 x 32,5	2 1/2 x 10 1/4 x 12 3/4	3,8	133	19.9955.0581
10 x 26 x 32,5	4 x 10 1/4 x 12 3/4	6	210	19.9955.0582

Einsatz GN 2/3 / insert GN 2/3

Größe cm	size in.	Inhalt Ltr.	cap. oz.	
6,5 x 35,4 x 32,5	2 1/2 x 14 x 12 3/4	5,5	192,5	19.9955.0585
10 x 35,4 x 32,5	4 x 14 x 12 3/4	8,5	297,5	19.9955.0586

Einsatz GN 1/1 / insert GN 1/1

Größe cm	size in.	Inhalt Ltr.	cap. oz.	
6,5 x 53 x 32,5	2 1/2 x 20 3/4 x 12 3/4	8,5	297,5	19.9955.0589
10 x 53 x 32,5	4 x 20 3/4 x 12 3/4	13,3	465,5	19.9955.0590



Porzellan-Einsatz, zu Chafing Dish

GN porcelain insert, for chafing dish

GN intérieur en intérieur, pour chafing dish

GN interior porcelana, para chafing dish

GN interno in porcellana, per chafing dish

Porzellan / porcelain

Porzellaneinsatz GN $\frac{3}{6}$ - 20 / Porcelain insert GN $\frac{3}{6}$ - 20

Größe cm	size in.	Höhe cm	height in.	
35,4 / 17,4 x 32,5 / 16,2	14 (7) x 12 $\frac{3}{4}$ (6 $\frac{1}{3}$)	2	$\frac{3}{4}$	55.0219.9800

Porzellaneinsatz GN $\frac{3}{6}$ - 65 / Porcelain insert GN $\frac{3}{6}$ - 65

Größe cm	size in.	Höhe cm	height in.	
35,4 / 17,4 x 32,5 / 16,2	14 (7) x $\frac{3}{4}$ (6 $\frac{1}{3}$)	6,5	2 $\frac{1}{2}$	55.0220.9800

Porzellaneinsatz GN $\frac{1}{6}$ - 65 / Porcelain insert GN $\frac{1}{6}$ - 65

Größe cm	size in.	Höhe cm	height in.	
16,2 x 17,5	6 $\frac{1}{3}$ x 7	6,5	2 $\frac{1}{2}$	55.0222.9800

Porzellaneinsatz GN $\frac{1}{4}$ - 65 / Porcelain insert GN $\frac{1}{4}$ - 65

Höhe cm	height in.	Größe cm	size in.	
6,5	2 $\frac{1}{2}$	26,5 x 16,2	10 $\frac{1}{2}$ x 6 $\frac{2}{3}$	55.0226.9800

Einsatz GN $\frac{1}{3}$ / insert GN $\frac{1}{3}$

Größe cm	size in.	Inhalt Ltr.	cap. oz.	
2 x 17,5 x 32,5	$\frac{3}{4}$ x 7 x 12 $\frac{3}{4}$	0,4	14	60.3055.9990
6,5 x 17,5 x 32,5	2 $\frac{1}{2}$ x 7 x 12 $\frac{3}{4}$	1,9	64,2	60.3047.9990

Einsatz GN $\frac{1}{2}$ / insert GN $\frac{1}{2}$

Größe cm	size in.	Inhalt Ltr.	cap. oz.	
2 x 26,5 x 32,5	$\frac{3}{4}$ x 10 $\frac{1}{2}$ x 12 $\frac{3}{4}$	0,7	24,5	60.3054.9990
6,5 x 26,5 x 32,5	2 $\frac{1}{2}$ x 10 $\frac{1}{2}$ x 12 $\frac{3}{4}$	3,3	111,54	60.3045.9990

Einsatz GN $\frac{2}{3}$ / insert GN $\frac{2}{3}$

Größe cm	size in.	Inhalt Ltr.	cap. oz.	
2 x 35,4 x 32,5	$\frac{3}{4}$ x 14 x 12 $\frac{3}{4}$	0,8	28	60.3056.9990
6,5 x 35,4 x 32,5	2 $\frac{1}{2}$ x 14 x 12 $\frac{3}{4}$	4,65	157,17	60.3046.9990

Einsatz GN $\frac{1}{1}$ / insert GN $\frac{1}{1}$

Größe cm	size in.	Inhalt Ltr.	cap. oz.	
6,5 x 53 x 32,5	2 $\frac{1}{2}$ x 20 $\frac{3}{4}$ x 12 $\frac{3}{4}$	7,3	246,74	60.3044.9990

Einsatz GN $\frac{2}{4}$ / insert GN $\frac{2}{4}$

Größe cm	size in.	Inhalt Ltr.	cap. oz.	
2 x 16 x 53	$\frac{3}{4}$ x 6 $\frac{1}{4}$ x 20 $\frac{3}{4}$	0,7	24,5	60.3057.9990
6,5 x 16 x 53	2 $\frac{1}{2}$ x 6 $\frac{1}{4}$ x 20 $\frac{3}{4}$	2,5	87,5	60.3048.9990



Heizelement

heating element
 plaque électrique
 placa calentadora
 piastra riscaldante

für WMF Chafing Dishes GN 1/1 ohne Rolltop-Deckel /
 suitable for all WMF chafing dishes GN 1/1 without full rolltop cover

Größe	size
cm	in.
24 x 24	9 1/2 x 9 1/2

Heizelement 230 V / 1000 W /
 heating element 230 V / 1000 W

06.2082.6044



Adapter für Elektroheizteil

holder for heating element
 adaptateur pour plaque électrique
 adaptador para placa calentadora
 adattatore per piastra riscaldante

zum problemlosen Einsatz von Heizelement 06.2082.6044 und
 06.2082.9990 für WMF Chafing Dishes GN 1/1 ohne Rolltop-Deckel /
 suitable for easy use of heating element 06.2082.6044 and
 06.2082.9990 for all WMF chafing dishes GN 1/1 without full rolltop
 cover

Cromargan® / stainless 18/10

Höhe	height	Größe	size
cm	in.	cm	in.
7	2 3/4	25 x 20	9 3/4 x 7 3/4

06.3272.6039



Heizelement

heating element
 plaque électrique
 placa calentadora
 piastra riscaldante

für alle großen runden WMF Chafing Dishes, VDE geprüft /
 suitable for all big round WMF chafing dishes, VDE proved

Größe	size
cm	in.
20 x 20	7 3/4 x 7 3/4

Heizelement 140-250 V / 270 W /
 heating element 140-250 V / 270 W

55.0096.6044

Heizelement 100-120 V / 230 W /
 heating element 100-120 V / 230 W

55.0096.9990

Heizelement 230 V / 550 W mit Regler /
 heating element 230 V / 550 W heat adjustable

06.2095.6046



Heizelement

heating element
 plaque électrique
 place calentadora
 piastra riscaldante

für WMF Chafing Dishes HOT & FRESH GN $\frac{2}{3}$ und rund /
 suitable for WMF chafing dishes HOT & FRESH GN $\frac{2}{3}$ and round

Größe	size
cm	in.
25 x 20	9 $\frac{3}{4}$ x 7 $\frac{3}{4}$

Heizelement, 140-250 V / 220 W /
 heating element, 140-250 V / 220 W
 Heizelement 120 V / 220 W /
 heating element 120 V / 220 W

55.0095.6044

55.0135.9990



Heizelement

heating element
 plaque électrique
 placa calentadora
 piastra riscaldante

für WMF Chafing Dishes GN $\frac{1}{1}$ und GN $\frac{2}{3}$, VDE geprüft /
 suitable for WMF chafing dishes GN $\frac{1}{1}$ and GN $\frac{2}{3}$, VDE proved

Größe	size
cm	in.
25 x 20	9 $\frac{3}{4}$ x 7 $\frac{3}{4}$

Heizelement 230 V / 600 W /
 heating element 230 V / 600 W
 Heizelement 120 V / 600 W /
 heating element 120 V / 600 W
 Heizelement 230 V / 700 W mit Regler /
 heating element 230 V / 700 W heat adjustable
 Heizelement 120 V / 700 W mit Regler /
 heating element 120 V / 700 W heat adjustable

55.0097.6044

55.0097.9990

06.3286.6046

55.0136.9990



Brennstoffdosenhalter

burner holder
 porte brûleur
 soporte quemador
 fornello

zur problemlosen Umstellung von elektrischer Heizung auf Brennstoff.
 Passend für alle WMF Chafing Dishes GN $\frac{1}{1}$ und HOT & FRESH /
 for uncomplicated conversion from electrical to burner heating. Fitting
 for all WMF chafing dishes GN $\frac{1}{1}$ and HOT & FRESH

Cromargan® / stainless 18/10

Größe	size
cm	in.
20 x 26 x 8,2	8 x 10 $\frac{1}{4}$ x 3 $\frac{1}{4}$

06.3322.6039



Brennstoffdosenhalter

burner holder
 porte brûleur
 soporte quemador
 fornello

zur problemlosen Umstellung von elektrischer Heizung auf Brennstoff.
 Passend für alle runden Chafing Dishes CHANGE /
 for uncomplicated conversion from electrical to burner heating. Fitting
 for all round WMF chafing dishes CHANGE

Cromargan® / stainless 18/10

Höhe	height	Größe	size	
cm	in.	cm	in.	
8,5	3 1/4	12,5 x 20	5 x 8	06.3940.6039



Brennstoffdose

solid alcohol
 alcool solidifié
 combustible
 alcool solido

Großpackung 36 St. /
 large package 36 pcs.

Inhalt	cap.
Ltr.	oz.
je Dose 0,2	each tin 7

60.3002.0690



Besteckablage

rack for utensils
 support couverts à servir
 soporte cubiertos servir
 porta posante

passend in alle WMF Chafing Dishes GN 1/1 in Standard- und Economy-
 Ausführung /
 fitting for all WMF chafing dishes GN 1/1 design Standard and Economy

Cromargan® / stainless 18/10

Größe	size	
cm	in.	
30 x 9	12 x 3 1/2	06.3296.6030



Besteckablage

rack for utensils
support couverts à servir
soporte cubiertos servir
porta posante

zum Einhängen in die Rahmen aller GN 1/1 Chafing Dishes CHANGE und HOT & FRESH, kann auch ohne Chafing Dish freistehend verwendet werden. /

to hinge in the frames of all GN 1/1 chafing dishes CHANGE and HOT & FRESH, can also be used on its own without Chafing Dish.

Cromargan®, Porzellan weiß / stainless 18/10, porcelain white

Tablett/Besteckhalter / tray/cutlery holder

Größe	size	
cm	in.	
27,9 x 12 x 7,1	11 x 4 ³ / ₄ x 2 ³ / ₄	

06.3539.6040

Porzellanschale / porcelain bowl

Größe	size	
cm	in.	
21 x 8,7 x 3,25	8 ¹ / ₄ x 3 ¹ / ₂ x 1 ¹ / ₄	

60.3540.9990

* Artikel einzeln bestellen / please order articles separately



Zwischensteg Induktion

connecting shelf
traverse
pasarela
ponticello

passend zu Chafing Dish HOT & FRESH /
fitting with Chafing Dish HOT & FRESH

Cromargan® / stainless 18/10

55.0082.6040

Chafing Dish - Besteck

chafing dish serving set
 service pour chafing dish
 cubiertos para chafing dish
 posate chafing dish

Cromargan® / stainless 18/10

Chafing Dish Gabel / chafing dish fork

Länge	length
cm	in.
26	10 ¹ / ₄

12.8386.6042



Chafing Dish Löffel / chafing dish spoon

Länge	length
cm	in.
26	10 ¹ / ₄

12.8386.6041



Chafing Dish Gabel / chafing dish fork

Länge	length
cm	in.
26	10 ¹ / ₄

12.8249.6040



Salatgabel / salad fork

Länge	length
cm	in.
26	10 ¹ / ₄

12.8343.6042



Chafing Dish Gabel / chafing dish fork

Länge	length
cm	in.
32,5	12 ³ / ₄

12.8381.6042



Chafing Dish Löffel / chafing dish spoon

Länge	length
cm	in.
32,5	12 ³ / ₄

12.8381.6041



Fleischgabel / serving fork

Länge	length
cm	in.
32,5	12 ³ / ₄

12.8382.6040



Nudellöffel / pasta serving spoon

Länge	length
cm	in.
31,5	12 ¹ / ₂

12.8383.6040



Chafing Dish Gabel / chafing dish fork

Länge	length
cm	in.
39	15 ¹ / ₄

12.8387.6042



Chafing Dish Löffel / chafing dish spoon

Länge	length
cm	in.
39	15 ¹ / ₄

12.8387.6041





Coffee Urn, "Basic"
CHANGE

coffee urn, "Basic"
coffee urn, "Basic"
urna de café, "Basic"
coffee urn, "Basic"

elektrisch und mit Brennstoff beheizbar. Heizelemente (110-250 V/ 150 W) und Brennstoffhalter bitte separat bestellen. / electrically and sterno heated. Please order heating elements (110-250 V/150W) separately.

Cromargan® / stainless 18/10

Höhe	height	Inhalt	cap.	Ø	Ø	
cm	in.	Ltr.	oz.	cm	in.	
54,5	21½	10	338	26	10¼	06.1520.6040
63,2	25	15	507	26	10¼	06.1525.6040

Zubehör / accessory:

Heizelement Coffee Urn / heating element 19.9999.9879

Brennstoffdose / solid alcohol 60.3002.0690

Inhalt cap.
Ltr. oz.
je Dose 0,2 each tin 7

Brennstoffhalter Coffee Urn / burner holder coffee urn 06.1520.6039

Höhe	height	Ø	Ø
cm	in.	cm	in.
12,8	5	17	6¾



Coffee Urn, "Manhattan"
CHANGE

coffee urn, "Manhattan"
coffee urn, "Manhattan"
urna de café, "Manhattan"
coffee urn, "Manhattan"

elektrisch und mit Brennstoff beheizbar. Heizelemente (110-250 V/ 150 W) und Brennstoffhalter bitte separat bestellen. / electrically and sterno heated. Please order heating elements (110-250 V/150W) separately.

Cromargan® / stainless 18/10

Höhe	height	Inhalt	cap.	Ø	Ø	
cm	in.	Ltr.	oz.	cm	in.	
54,5	21½	10	338	26	10¼	06.1524.6040
63,2	25	15	507	26	10¼	06.1529.6040

Zubehör / accessory:

Heizelement Coffee Urn / heating element 19.9999.9879

Brennstoffdose / solid alcohol 60.3002.0690

Inhalt cap.
Ltr. oz.
je Dose 0,2 each tin 7

Brennstoffhalter Coffee Urn / burner holder coffee urn 06.1520.6039

Höhe	height	Ø	Ø
cm	in.	cm	in.
12,8	5	17	6¾



**Brennstoffhalter Coffee Urn
CHANGE**

burner holder coffee urn
porte brûleur coffee urns
soporte quemador urna de café
fornello coffee urn

passend zu Coffee Urns 10 und 15 l CHANGE /
fitting for coffee urns 10 and 15 l CHANGE

Cromargan® / stainless 18/10

Höhe	height	Ø	Ø
cm	in.	cm	in.
12,8	5	17	6 ³ / ₄

06.1520.6039



Heizelement Coffee Urn

heating element
plaque électrique
placa calentadora
piastra riscaldante

passend zu Coffee Urns 10 und 15 l CHANGE, 140 - 250 V, 150 W,
selbstregelnd /
fitting for coffee urns 10 and 15 l CHANGE, 140 - 250 V, 150 W, self-
regulating

19.9999.9879



Schild mit Kette

name plate with chain
étiquette avec chaîne
etiqueta con cadena
targhetta con aggancio a catenella

passend für Coffee Urns, individuelle Kennzeichnung möglich. Preis auf
Anfrage. /
fitting on Coffee Urns, individual engraving possible. Please ask for
respective costs.

Cromargan® / stainless 18/10

Länge	length
cm	in.
63	24 ³ / ₄

06.3151.6040



WMF

WMF CHANGE Cerealien Dispenser: Dreh- und Angelpunkt. Für einen guten Morgen.

WMF CHANGE cereals dispensers:
Where it's all at. For a good morning.

Zu einem erfrischenden Start in den Tag gehören eine abwechslungsreiche Ernährung und ein schöner Anblick. Für beides sorgt der WMF CHANGE Cerealien Dispenser als glänzender Energiespender auf dem Frühstücksbuffet. Seine ausgewogene Mischung aus Form und Funktion verbindet sich zu zwei Platz sparenden Produktvarianten.

A varied diet and good looks are important for a vigorous start to the day. Both are in place with a WMF CHANGE cereals dispenser as a glamorous energy-giving centrepiece on the breakfast buffet. Its balanced combination of form and function merges into two space-saving product variants.



Spielend einfache Frische.

Die hygienischen Behälter sind leicht zu entnehmen, nachzufüllen und komplett spülmaschinengeeignet. Einfach am Bedienknopf drehen und die portionierte Entnahme der verschiedenen Müsli- und Getreideflocken regelt sich von selbst.

Totally convenient freshness.

The hygienic containers are easy to remove and refill, as well as being completely dishwasher-safe. Simply turn the knob to dispense a measured helping of muesli or the cereal of your choice.

Veredelte Frühschicht.

Das hochwertige Cromargan® der WMF CHANGE Cerealien Dispenser ist je nach Variante mattiert oder poliert. Die drehbare Variante lässt durch die platzsparende Anordnung der Cerealien-Röhren auch auf kleinem Raum keine Frühstückswünsche offen.

Looking good at an early hour.

The high-quality Cromargan® of the WMF CHANGE cereals dispensers can be matte-finished or polished, depending on the version. If space is at a premium, the revolving version with the compact arrangement of the cereals cylinders leaves ample room for everything else that belongs on the breakfast table.

Perfekte Harmonie.

Die Produkte der WMF Collection CHANGE sind variabel und stil-sicher. Egal ob Dispenser, Coffee Urns oder Chafing Dishes, alles passt zusammen und harmonisiert mit jeder Einrichtung.

Perfect harmony.

The products in the WMF CHANGE collection are variable and stylistically flawless. Dispensers, coffee urns and chafing dishes: everything matches and harmonises with any interior fittings.



Produktvarianten Product variants



Reihenlösung
In-line solution



rund/drehbar (nur Modell „BASIC“)
Round/revolving ("BASIC" model only)

Ausführungen CHANGE CHANGE models



„BASIC“



„MANHATTAN“



„PALAST“
(Sonderausführung auf Anfrage.
Special design on request.)



Cerealiendispenser, drehbar „Basic“ CHANGE

cereal dispenser, rotatable, „Basic“
dispenseur de céréales, rotatif, „Basic“
dispensador de cereales, rotativo, „Basic“
dispencer cereali, girabile, „Basic“

mit 3 Behältern, drehbar, portionierte und hygienische Entnahme durch Drehen, leicht zu befüllen, spülmaschinengeeignet, Durchmesser Behälter 11,3 cm; Inhalt jeweils 3,5 l; Unterstellhöhe 9,5 cm /
with 3 containers, turnable, hygienic portioning by turning, easy to refill, dishwasher safe, dia. container 4¹/₂ in.; cap. each container 118,3 oz.; clear height 3³/₄ in.

Gestell Cromargan®, Behälter PMMA farblos /
stand stainless 18/10, container PMMA clear

Höhe	height	Ø	Ø
cm	in.	cm	in.
59,7	23 ¹ / ₂	35,7	14

06.3530.6040

Ersatzteil / spare part:

Cerealienbehälter / container cereal dispenser

06.3530.6041



Cerealiendispenser, Reihenlösung „Basic“ CHANGE

cereal dispenser, in-line „Basic“
dispenseur de céréales, in-line „Basic“
dispensador de cereales, in-line „Basic“
dispencer cereali, in-line „Basic“

mit 3 Behältern, portionierte und hygienische Entnahme durch Drehen, leicht zu befüllen, spülmaschinengeeignet, Durchmesser Behälter 11,3 cm; Inhalt jeweils 3,5 l; Unterstellhöhe 9,5 cm /
with 3 containers, hygienic portioning by turning, easy to refill, dishwasher safe, dia. container 4¹/₂ in.; cap. each container 118,3 oz.; clear height 3³/₄ in.

Gestell Cromargan®, Behälter PMMA farblos /
stand stainless 18/10, container PMMA clear

Größe	size
cm	in.
39 x 25 x 59,7	15 ¹ / ₄ x 9 ³ / ₄ x 23 ¹ / ₂

06.3640.6040

Ersatzteil / spare part:

Cerealienbehälter / container cereal dispenser

06.3530.6041



Cerealiendispenser, Reihenlösung „Manhattan“ CHANGE

cereal dispenser, in-line „Manhattan“
dispenseur de céréales, in-line „Manhattan“
dispensador de cereales, in-line „Manhattan“
dispencer cereali, in-line „Manhattan“

mit 3 Behältern, portionierte und hygienische Entnahme durch Drehen, leicht zu befüllen, spülmaschinengeeignet, Durchmesser Behälter 11,3 cm; Inhalt jeweils 3,5 l; Unterstellhöhe 9,5 cm /
with 3 containers, hygienic portioning by turning, easy to refill, dishwasher safe, diam. container 4 1/2 in.; cap. each container 118,3 oz.; clear height 3 3/4 in.

Gestell Cromargan®, Behälter PMMA farblos /
stand stainless 18/10, container PMMA clear

Größe	size
cm	in.
39 x 25 x 59,6	15 1/4 x 9 3/4 x 23 1/2

06.3645.6040

Ersatzteil / spare part:

Cerealienbehälter / container cereal dispenser

06.3530.6041

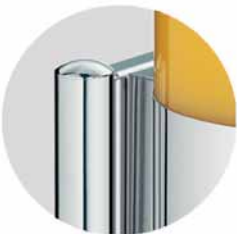

Saftdispenser, „Basic“ CHANGE

juice dispenser, „Basic“
dispenseur de jus, „Basic“
dispensador de zumo, „Basic“
dispenser per succhi di frutta, „Basic“

individuell höhenverstellbar, klare Kennzeichnung, tropffreier, hygienischer Auslauf, Kühlmöglichkeit durch Eisröhre (Zubehör). Attraktive Motive für die Frontseite zum Download unter [www.wmf-hotel.de /](http://www.wmf-hotel.de/)

individually height adjustable, clear labelling, non dripping hygienic spout, cooling with ice tube (accessory). Attractive motifs for the frontside for download at www.wmf-hotel.de

Gestell Cromargan®, Behälter SAN-Kunststoff transparent /
stand stainless 18/10, container SAN plastic clear

Mindesthöhe	min. height	Maximalhöhe	max. height	Größe	size
cm	in.	cm	in.	cm	in.
52	20 1/2	60	23 1/2	30,5 x 20	12 x 8

Inhalt mit Eisröhre	cap. incl. ice tube	Inhalt ohne Eisröhre	cap. w/o ice tube
Ltr.	oz.	Ltr.	oz.
5	175	6,5	227,5

06.3130.6040

Zubehör / accessory:

Eisröhre / ice tube

06.3130.6043

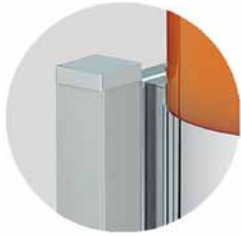

Saftdispenser, "Manhattan" CHANGE

juice dispenser, "Manhattan"
dispenseur de jus, "Manhattan"
dispensador de zumo, "Manhattan"
dispenser per succhi di frutta, "Manhattan"

individuell höhenverstellbar, klare Kennzeichnung, tropffreier, hygienischer Auslauf, Kühlmöglichkeit durch Eisröhre (Zubehör). Attraktive Motive für die Frontseite zum Download unter www.wmf-hotel.de/

individually height adjustable, clear labelling, non dripping hygienic spout, cooling with ice tube (accessory). Attractive motifs for the frontside for download at www.wmf-hotel.de

Gestell Cromargan®, teilmattiert, Behälter SAN-Kunststoff transparent / stand stainless 18/10, partly satin finished, container SAN plastic clear

Mindesthöhe cm	min. height in.	Maximalhöhe cm	max. height in.	Größe cm	size in.
52	20½	60	23½	30,5 x 20	12 x 8

Inhalt mit Eisröhre Ltr.	cap. incl. ice tube oz.	Inhalt ohne Eisröhre Ltr.	cap. w/o ice tube oz.
5	175	6,5	227,5

06.3135.6040

Zubehör / accessory:

Eisröhre / ice tube

06.3130.6043



Milchdispenser, "Basic" CHANGE

milk dispenser, "Basic"
dispenseur de lait, "Basic"
dispensador leche, "Basic"
dispenser latte, "Basic"

individuell höhenverstellbar, klare Kennzeichnung, tropffreier, hygienischer Auslauf, Kühlmöglichkeit durch Eisröhre (Zubehör). Attraktive Motive für die Frontseite zum Download unter www.wmf-hotel.de/

individually height adjustable, clear labelling, non dripping hygienic spout, cooling with ice tube (accessory). Attractive motifs for the frontside for download at www.wmf-hotel.de

Gestell Cromargan®, Behälter SAN-Kunststoff lichtundurchlässig / stand stainless 18/10, container SAN plastic opaque white

Mindesthöhe cm	min. height in.	Maximalhöhe cm	max. height in.	Größe cm	size in.
52	20½	60	23½	30,5 x 20	12 x 8

Inhalt mit Eisröhre Ltr.	cap. incl. ice tube oz.	Inhalt ohne Eisröhre Ltr.	cap. w/o ice tube oz.
5	175	6,5	227,5

06.3390.6040

Zubehör / accessory:

Eisröhre / ice tube

06.3130.6043



Milchdispenser, "Manhattan" CHANGE

milk dispenser, "Manhattan"
dispenseur de lait, "Manhattan"
dispensador leche, "Manhattan"
dispenser latte, "Manhattan"

individuell höhenverstellbar, klare Kennzeichnung, tropffreier, hygienischer Auslauf, Kühlmöglichkeit durch Eiströhre (Zubehör). Attraktive Motive für die Frontseite zum Download unter www.wmf-hotel.de/

individually height adjustable, clear labelling, non dripping, hygienic spout, cooling with ice tube (accessory). Attractive motifs for the frontside for download at www.wmf-hotel.de

Gestell Cromargan®, teilmattiert, Behälter SAN-Kunststoff
lichtundurchlässig /

stand stainless 18/10, partly satin finished, container SAN plastic
opaque white

Mindesthöhe cm	min. height in.	Maximalhöhe cm	max. height in.	Größe cm	size in.
52	20 ¹ / ₂	60	23 ¹ / ₂	30,5 x 20	12 x 8

Inhalt mit Eiströhre Ltr.	cap. incl. ice tube oz.	Inhalt ohne Eiströhre Ltr.	cap. w/o ice tube oz.
5	175	6,5	227,5

06.3395.6040

Zubehör / accessory:

Eiströhre / ice tube

06.3130.6043



Eiströhre

ice tube
tube à glace
tubo para hielo
tubo in acciaio

mit Crash Ice zu befüllen. Passend zu allen Saft- und Milchdispensern
CHANGE /

to be filled up with crash-ice. Fitting for all juice and milk dispensers
CHANGE

Cromargan® / stainless 18/10

Inhalt Ltr.	cap. oz.	Höhe cm	height in.	Ø cm	Ø upper in.
1	35	27	10 ³ / ₄	7,5	35

06.3130.6043

**Softbar, mit Gläserbord**

juice bar, with glass holder
bar à jus de fruit, avec étagère pour verres
set para zumos, con portavasos
set girevole per succhi di frutta

bestehend aus: Gestell, 4 Kühlpellets /
consisting of: stand, 4 cooling elements

drehbar /
turnable

Cromargan®, Plexiglas / stainless 18/10, plexiglass

Höhe	height	Ø	Ø
cm	in.	cm	in.
47	18 1/2	47	18 1/2

06.3232.6040

Zubehör / accessory:

Glaskrug / glass pitcher

60.3061.9990

Inhalt	cap.
Ltr.	oz.
1,5	52,5

Ersatzteil / spare part:

Kühlpellet / cooling element

19.9999.5850

Ø	Ø
cm	in.
16	6 1/4

**Glaskrug**

glass pitcher
broc en verre
jarra de cristal
brocca di vetro

2 Stück passen in die Eiswannen GN 1/2, 4 St. in GN 1/1 /
2 pcs. fitting in ice trays GN 1/2, 4 St. in GN 1/1

Glas / glass

Inhalt	cap.	Höhe	height
Ltr.	oz.	cm	in.
2	67	30	11 3/4

09.4117.2000



Getränkekühler

DIVA

beverage cooler
 seu à boisson
 cubo bebida
 rinfresca bevanda

doppelwandig und stapelbar. Kann verwendet werden mit Kühlelement 55.0125.9990, für 3 Wasser-, Saft-, Milchkaraffen 06.1770.6040, 3 Getränkeflaschen (Bsp. Wasser, Wein, etc.) mit max. 10 cm Flaschendurchmesser, 6 Getränkeflaschen (Bsp. Wasser, Saft, Bier etc.) mit max. 7 cm Flaschendurchmesser /

double wall and stackable. Can be used with cooling element 55.0125.9990, for 3 water/juice/milk decanter 06.1770.6040, 3 beverage bottles (e.g. water, wine, etc.) with max. 4 in. bottle diameter, 6 beverage bottles (e.g. water, juice, beer, etc.) with max. 2 3/4 in. bottle diameter

Cromargan® / stainless 18/10

Größe cm	size in.	Inhalt Ltr.	cap. oz.	
27,5 x 26,2 x 17	10 ³ / ₄ x 10 ¹ / ₄ x 6 ³ / ₄	7,3	257	55.0124.6040



Kühlelement

DIVA

cooling element
 élément réfrigérante
 elemento refrigerador
 elemento per il ghiaccio

mit Kühlgelfüllung zum Einfrieren. Stapelbar. Kann verwendet werden mit Getränkekühler 55.0124.6040 oder separat, für 3 Wasser-, Saft-, Milchkaraffen 06.1770.6040, 3 Getränkeflaschen (Bsp. Wasser, Wein, etc.) mit max. 10 cm Flaschendurchmesser, 6 Getränkeflaschen (Bsp. Wasser, Saft, Bier etc.) mit max. 7 cm Flaschendurchmesser / with cooling core for freezing. Stackable. Can be used with beverage cooler 55.0124.6040 or separately, for 3 water decanter 06.1770.6040, 3 beverage bottles (e.g. water, wine, etc.) with max. 4 in. bottle diameter, 6 beverage bottles (e.g. water, juice, beer, etc.) with max. 2 3/4 in. bottle diameter

Kunststoff / plastic

Größe cm	size in.	
25,3 x 24 x 13,3	10 x 9 ¹ / ₂ x 5 ³ / ₄	55.0125.9990





Karaffe

BASIC

decanter
carafe
garrafa

Deckel öffnet und schließt automatisch. /
Lid opens and closes automatically.

Glas, Cromargan®, Silikon / Glass, Cromargan®, silicone

Höhe	height	Inhalt	cap.
cm	in.	Ltr.	oz.
30	11 ³ / ₄	1	35

06.1770.6040

Ersatzteil / spare part:

Ersatzkaraffe / Replacement decanter

60.1770.9990

Karaffe

BASIC

decanter
carafe
garrafa

Mit Schwenkverschluss - CloseUp - und integriertem Sieb. /
With swivel closure - CloseUp - and integrated sieve.

Cromargan®, Silikon / Cromargan®, silicone

Höhe	height	Inhalt	cap.
cm	in.	Ltr.	oz.
30	11 ³ / ₄	1	35

06.1765.6040





Cerealien-/Saft-Set

set for cereal/juice dispenser
 presentoir a cereales/jus de fruit
 set para cereales/jugo
 set per cereali/succhi

bestehend aus Gestell und 3 Schüttflöten mit Deckel, Inhalt je 2 Ltr., für Saft, Milch oder Cerealien /
 consisting of base and 3 containers with lid, cap. 67,6 oz. each, for juice, milk or cereals

Cromargan®, SAN klar / Cromargan®, SAN clear

Größe	size	
cm	in.	
44,5 x 17,2 x 29,4	17 1/2 x 6 3/4 x 11 1/2	

06.3648.6040

Ersatzteil / spare part:

Gestell, 3 Ausschnitte / base, for 3 inserts

06.3648.6045

Größe	size
cm	in.
44,5 x 17,2 x 3	17 1/2 x 6 3/4 x 1 1/4

Cerealien/Saft-Flöte / cereal/juice flute

06.8253.6040

Höhe	height	Inhalt	cap.	Ø	Ø
cm	in.	Ltr.	oz.	cm	in.
29,4	11 1/2	2	67,6	12,6	5



Buffet-Set, Glas

buffet set, glass
 ensemble buffet, verre
 juego de bufete, cristal
 set per buffet, vetro

bestehend aus Gestell und 3 Gläsern (Inhalt je 0,7 Ltr.) inkl. Deckel mit Beschriftungsmöglichkeit. Beschriftungs-Beispiele zum Download auf www.wmf-hotel.de /
 consisting of base with 3 glasses (cap. 23,66 oz. each) incl. lid. Motifs for labelling available for download on www.wmf-hotel.de

Cromargan®, Glas / stainless 18/10, glass

Größe	size
cm	in.
44,5 x 17,2 x 13	17 1/2 x 6 3/4 x 5

06.8242.6040

Ersatzteil / spare part:

Gestell, 3 Ausschnitte / base, for 3 inserts

06.3648.6045

Größe	size
cm	in.
44,5 x 17,2 x 3	17 1/2 x 6 3/4 x 1 1/4

Glasbehälter / glass bowl

60.8241.9990

Höhe	height	Inhalt	cap.	Ø	Ø
cm	in.	Ltr.	oz.	cm	in.
13	5	0,75	25,35	10,5	4 1/4

Deckel, mit Plexihülle / lid, with plexi cover
 Plexihülle für Deckel / plastic holder for lid

06.8241.6042
 60.8241.9996



Buffet-Set, Porzellan

buffet set, porcelain
ensemble buffet, porcelaine
juego de bufete, porcelana
set per buffet, porcellana

bestehend aus Gestell und 3 Porzellanbehältern (Inhalt je 0,65 Ltr.)
inkl. Deckel mit Beschriftungsmöglichkeit. Beschriftungs-Beispiele zum
Download auf www.wmf-hotel.de /
consisting of base with 3 porcelain bowls (cap. 21,97 oz. each) incl. lid.
Motifs for labelling available for download on www.wmf-hotel.de

Cromargan®, Porzellan / stainless 18/10, porcelain

Größe	size	
cm	in.	
44,5 x 17,2 x 13	17 ¹ / ₂ x 6 ³ / ₄ x 5	06.8257.6040

Ersatzteil / spare part:

Gestell, 3 Ausschnitte / base, for 3 inserts 06.3648.6045

Größe	size
cm	in.
44,5 x 17,2 x 3	17 ¹ / ₂ x 6 ³ / ₄ x 1 ¹ / ₄

Porzellanbehälter / porcelain bowl 60.8258.9990

Höhe	height	Inhalt	cap.	Ø	Ø
cm	in.	Ltr.	oz.	cm	in.
13	5	0,65	21,97	10,5	4 ¹ / ₄

Deckel, mit Plexihülle / lid, with plexi cover 06.8241.6042

Plexihülle für Deckel / plastic holder for lid 60.8241.9996



Teller-/Schalengestell

plate and bowl stand
support pour bols à céréales
soporte para platos o fuentes
supporto per piatti e coppe

ohne Glasschalen /
without glass bowls

Cromargan® / stainless 18/10

Höhe	height	Ø Ring	Ø ring
cm	in.	cm	in.
40,4	16	19,5	7 ³ / ₄

06.4394.6040

Zubehör / accessory:

Glasschale, 20 cm / glass bowl, 20 cm 19.9999.8642

Dessertgestell

dessert stand
présentoir à gâteau
soporte plato postre
porta piattini per dessert

ohne Gläser /
w/o glasses

Cromargan® / stainless 18/10

Größe	size	
cm	in.	
40,6 x 7 x 4,9	16 x 2 ³ / ₄ x 2	06.8230.6040

Zubehör / accessory:

Glas S (VPE 6 Stk.) / glass S (unit 6 pcs.) 60.2506.9990



Dessertgestell PURE EXCLUSIV

dessert stand
présentoir à gâteau
soporte plato postre
porta piattini per dessert



in 2 Holzvarianten. Mit 3 Einsätzen für wahlweise Gläser S, Tassen S oder Sahnekännchen (o. Abb.) von KaffeeKultur und Tassen S von CultureCup (o. Abb.). Nicht spülmaschinengeeignet! (ohne Gläser) / in 2 wood versions. With 3 inserts alternatively for glasses S, cups S or creamer (w/o pic.) of CoffeeCulture and cups S CultureCup (w/o pic.). Not dishwasher-safe! (w/o glasses)

Cromargan®, Holz dunkel gebeizt, Holz lackiert / stainless 18/10, wood dark stained, wood lacquered

Menage klein dunkel / stand small dark

Größe	size	
cm	in.	
20,5 x 6,2 x 3,7	8 x 2 ¹ / ₂ x 1 ¹ / ₂	55.0039.6040

Menage klein natur / stand small nature

Größe	size	
cm	in.	
20,5 x 6,2 x 3,7	8 x 2 ¹ / ₂ x 1 ¹ / ₂	55.0039.6140

Glas S (VPE 6 Stk.) / glass S (unit 6 pcs.)

Höhe	height	Inhalt	cap.	
cm	in.	Ltr.	oz.	
7,4	3	0,1	3,4	60.2506.9990

* Artikel einzeln bestellen / please order articles separately



Dessertgestell PURE EXCLUSIV

dessert stand
présentoir à gâteau
soporte plato postre
porta piattini per dessert



in 2 Holzvarianten. Mit 3 Einsätzen für wahlweise Gläser S, Tassen S (o. Abb.) oder Sahnekännchen von KaffeeKultur und Tassen S von CultureCup (o. Abb.). Nicht spülmaschinengeeignet! / in 2 wood versions. With 3 inserts alternatively for glasses S, cups S (w/o pic.) or creamer of CoffeeCulture and cups S of CultureCup (w/o pic.). Not dishwasher-safe!

Cromargan®, Holz dunkel gebeizt, Holz lackiert / stainless 18/10, wood dark stained, wood lacquered

Menage klein dunkel / stand small dark

Größe	size	
cm	in.	
20,5 x 6,2 x 3,7	8 x 2 ¹ / ₂ x 1 ¹ / ₂	55.0039.6040

Menage klein natur / stand small nature

Größe	size	
cm	in.	
20,5 x 6,2 x 3,7	8 x 2 ¹ / ₂ x 1 ¹ / ₂	55.0039.6140

Sahnekännchen (VPE 6 Stk.) / creamer (unit 6 pcs.)

Höhe	height	Inhalt	cap.	
cm	in.	Ltr.	oz.	
7	2 ³ / ₄	0,1	3,4	55.0033.9990

Deckel mit Ausschnitt / lid with cut-out 55.0031.6040

Espresso- /Mokkalöffel (VPE 12 Stk.) / demi-tasse spoon (unit 12 pcs.) 54.9901.6040

* Artikel einzeln bestellen / please order articles separately





Dessertgestell

dessert stand
présentoir à gâteau
soporte platos postre
porta piattini per dessert

passend für Teller bis Ø 16 cm (ohne Teller) /
fitting for plates Ø 6¹/₄ in. (without plates)

Cromargan® / stainless 18/10

Höhe	height	Ø	Ø	Ø Ring	Ø ring
cm	in.	cm	in.	cm	in.
25,5	10	18,5	7 ¹ / ₄	10,5	4 ¹ / ₄

06.4397.6040



Serviergestell

serving stand
présentoir à assiette
soporte platos
portapiatti

passend für Teller Ø 26 cm (ohne Teller) /
fitting for plates Ø 10¹/₄ in. (without plates)

Cromargan® / stainless 18/10

Höhe	height	Ø	Ø	Ø Ring	Ø ring
cm	in.	cm	in.	cm	in.
40	15 ³ / ₄	28,5	11 ¹ / ₄	18,6	7 ¹ / ₄

06.4395.6040



Etagère, 3-teilig PURE

etagere, 3 parts
étagère, en 3 parties
frutero, de 3 pisos
porta frutta, 3 piani

Cromargan® / stainless 18/10

Höhe	height	Ø Schale	Ø bowl
cm	in.	cm	in.
52,5	20 ³ / ₄	46 / 37 / 28	18 / 14 ¹ / ₂ / 11

06.0470.6040



Mokkaétagère, 3-teilig

PURE

pastry stand, 3 parts
 porte petits fours, en 3 parties
 portapastas, de 3 pisos
 alzata portadolci, 3 piani

Cromargan® / stainless 18/10

Höhe	height	Ø Schale	Ø bowl
cm	in.	cm	in.
22,5	8 ³ / ₄	9 / 14 / 20	3 ¹ / ₂ / 5 ¹ / ₂ / 8

06.6903.6040



Etagère, 3-teilig

BISTRO

etagere, 3 parts
 étagère, en 3 parties
 frutero, de 3 pisos
 porta frutta, 3 piani

Cromargan®, Glas / stainless 18/10, glass

Höhe	height	Ø Schale	Ø bowl
cm	in.	cm	in.
56	22	30 / 38 / 50	11 ³ / ₄ / 15 / 19 ³ / ₄

06.6893.6040

Ersatzteil / spare part:

Glasschale klein / glass plate small	19.9999.8643
Glasschale mittel / glass plate medium	19.9999.8644
Glasschale groß / glass plate large	19.9999.8645



Etagère

etagere
étagère
frutero articulado
porta frutta

ohne Einsätze, Arme drehbar /
without inserts, insert holders turnable

rostfrei / stainless steel

Höhe	height	Ringe
cm	in.	psc.
51	20	4tlg.
70	27½	6tlg.

06.3010.6040

06.3011.6040



Glasschale, 20 cm

glass bowl, 20 cm
coupe verre glasskin, 20 cm
depósitos de cristal, 20 cm
interno in vetro, 20 cm

passend in Etagère 06.3010.6040, 06.3011.6040, 06.4394.6040 /
fitting in etagere 06.3010.6040, 06.3011.6040, 06.4394.6040

Höhe	height	Ø	Ø
cm	in.	cm	in.
8,5	3¼	20	8

19.9999.8642



Tablett, rund

service tray, round
plateau de service, rond
bandeja, redonda
vassoio, rotondo

passend in Etagère 06.3010.6040, 06.3011.6040 /
fitting in etagere 06.3010.6040, 06.3011.6040

Cromargan® / stainless 18/10

Ø außen	outer Ø	Ø innen	Ø inside
cm	in.	cm	in.
29,5	11½	24,5	9¾

06.3014.6041



Kühlbehälter, mit Kühlpellet

cooler, with cooling element
 coupe réfrigérante, avec élément réfrigérante
 recipiente, con acumulador de frío
 base, con elemento refrigerante

passend in Etagère 06.3010.6040, 06.3011.6040, zum Kühlen von
 Tablett 06.3014.6041 /

fitting in etagere 06.3010.6040, 06.3011.6040, to cool tray
 06.3014.6041

Cromargan® / stainless 18/10

Ø	Ø
cm	in.
19	7½

06.3014.6044

Ersatzteil / spare part:

Kühlpellet / cooling element

19.9999.5850



Früchtekorb

fruit basket
 panier à fruits
 frutero
 fruttiera

passend in Etagère 06.3010.6040, 06.3011.6040 nur in Verbindung mit
 Kühlbehälter 06.3014.6045 (bitte separat bestellen) /

fitting together with cooler 06.3014.6045 (please order separately) in
 etagere 06.3010.6040, 06.3011.6040

Cromargan® / stainless 18/10

Höhe	height	Ø	Ø
cm	in.	cm	in.
22,5	8¾	26	10¼

06.6521.6040



Plattenständer niedrig, GN 1/1

tray stand low, GN 1/1
 support pour plaques bas, GN 1/1
 soporte platos bajo, GN 1/1
 supporto piatto basso, GN 1/1

kombinierbar mit Servierplatten GN 1/1 06.2431.9990 (CORIAN), 06.7660.6040 (Edelstahl), 60.3053.9990 (Porzellan), 06.2432.9990 (Kunststoff), Kühlakku GN 1/2 und Abdeckhauben 06.2937.6040, 55.0134.6040 /
 combinable with serving plates GN 1/1 06.2431.9990 (CORIAN), 06.7660.6040 (stainless steel 18/10), 60.3053.9990 (Porcelain), 06.2432.9990 (Plastic), cooling block GN 1/2 and covers 06.2937.6040, 55.0134.6040

stapelbar /
 stackable

Cromargan® / stainless 18/10

Größe	size
cm	in.
51 x 30 x 12	20 x 11 ³ / ₄ x 4 ³ / ₄

55.0132.6040



Plattenständer hoch, GN 1/1

tray stand high, GN 1/1
 support pour plaques haut, GN 1/1
 soporte platos alto, GN 1/1
 supporto piatto alto, GN 1/1

kombinierbar mit Servierplatten GN 1/1 06.2431.9990 (CORIAN), 06.7660.6040 (Edelstahl), 60.3053.9990 (Porzellan), 06.2432.9990 (Kunststoff), Kühlakku GN 1/2 und Abdeckhauben 06.2937.6040, 55.0134.6040 /
 combinable with serving plates GN 1/1 06.2431.9990 (CORIAN), 06.7660.6040 (stainless steel 18/10), 60.3053.9990 (Porcelain), 06.2432.9990 (Plastic), cooling block GN 1/2 and covers 06.2937.6040, 55.0134.6040

stapelbar /
 stackable

Cromargan® / stainless 18/10

Größe	size
cm	in.
51 x 30 x 18	20 x 11 ³ / ₄ x 7

55.0133.6040



Kühlakku, GN 1/2

cooling block, GN 1/2
 brique réfrigérante, GN 1/2
 acumulador refrigerador, GN 1/2
 tavoletta per il ghiaccio, GN 1/2

2 Stück für Plattenständer GN 1/1 /
 2 pcs. for trays stands GN 1/1

Kunststoff mit Kühlflüssigkeit / plastic with cooling liquid

Kühlakku, Gastronorm 1/2 /
 cooling block, Gastronorm 1/2

Größe	size
cm	in.
25,5 x 20,3 x 3,2	10 x 8 x 1 ¹ / ₄

60.3065.9990



Platten, GN 1/1

platters, GN 1/1
 planche pour recipient, GN 1/1
 fuente, GN 1/1
 piatto, GN 1/1

passend auf Plattenständer hoch und niedrig und alle GN 1/1 Rahmen /
 fitting on tray stand high and low and all GN 1/1 frames



	Größe cm	size in.	Inhalt cap. Ltr. oz.	
CORIAN®	53 x 32,5	20 ³ / ₄ x 12 ³ / ₄		06.2431.9990
Cromargan® / GN 1/1	53 x 32,5	20 ³ / ₄ x 12 ³ / ₄		06.7660.6040
stainless 18/10				06.7660.6040
Porzellan / porcelain	2 x 53 x 32,5	3/4 x 20 ³ / ₄ x 12 ³ / ₄	1,4 49	60.3053.9990
Kunststoff / plastic	GN 1/1	53 x 32,5		06.2432.9990

Abdeckhaube

cover for trays
 cloche pour plateaux
 campana para bandejas
 coperchio adatto per vassoio

mit 2 seitlichen Eingriffen, passend für Tablett GN 1/1 ohne Griffe und
 Plattenständer niedrig/hoch /
 with two side openings, fitting for trays GN 1/1 without handles and on
 tray stands low/high

Kunststoff glasklar, Griff verchromt /
 high quality plastic, handle chrome plated

Größe cm	size in.
55,5 x 35 x 14,5	21 ³ / ₄ x 13 ³ / ₄ x 5 ³ / ₄

06.2937.6040



Abdeckhaube

cover for trays
 cloche pour plateaux
 campana para bandejas
 coperchio adatto per vassoio

halbrollend, passend für Platten GN 1/1 ohne Griffe und Plattenständer
 niedrig/hoch /
 half rolling, fitting for plates GN 1/1 without handles and tray stands
 low/high

Kunststoff glasklar, Griff verchromt /
 high quality plastic, handle chrome plated

Größe cm	size in.
53 x 32,5 x 17	20 ³ / ₄ x 12 ³ / ₄ x 6 ³ / ₄

55.0134.9990





**Tablett, rund
CLASSIC**

serving tray, round
plateau de service, rond
bandeja, redonda
vassoio, rotondo

Ø	Ø
cm	in.
29,5	11 ¹ / ₂
35	13 ³ / ₄
41,7	16 ¹ / ₂

Cromargan®	versilbert
stainless 18/10	silverplated
06.7260.6040	19.7260.6440
06.7261.6040	19.7261.6440
06.7262.6040	19.7262.6440



**Tablett, rund
BISTRO**

serving tray, round
plateau de service, rond
bandeja, redonda
vassoio, rotondo

stapelbar /
stackable

Cromargan® / stainless 18/10

Ø	Ø
cm	in.
42,6	16 ³ / ₄

06.7679.6040



Tablett, oval

serving tray, oval
plateau de service, ovale
bandeja, oval
vassoio, ovale

Cromargan® / stainless 18/10

Größe	size
cm	in.
51,6 x 39,3	20 ¹ / ₄ x 15 ¹ / ₂

06.7265.6040



**Kaffeetablett
PURE**

serving tray
plateau de service
bandeja
vassoio

stapelbar, oval /
stackable, oval

Cromargan® / stainless 18/10

Größe	size
cm	in.
27 x 17	10 ¹ / ₂ x 6 ³ / ₄

06.7550.6040



**Tablett, oval
PURE**

serving tray, oval
plateau de service, ovale
bandeja, oval
vassoio, ovale

passend für Toastständer 06.4280.6040 und Porzellanschale 3geteilt
60.3538.9990 /
suitable for toast rack 06.4280.6040 and for porcelain bowl 3pcs.
60.3538.9990

stapelbar /
stackable

Cromargan® / stainless 18/10

Größe	size
cm	in.
24,5 x 12	9 ¹ / ₂ x 4 ³ / ₄

06.7551.6040



**Tablett
URBAN**

tray
plateau
bandeja
vassoio

Cromargan® / stainless 18/10

Größe	size
cm	in.
23 x 10,7	8 x 4 ¹ / ₄

55.0058.6045



Tablett, oval

serving tray, oval
plateau de service, ovale
bandeja, oval
vassoio, ovale

Größe	size
cm	in.
22 x 15,5	8 ³ / ₄ x 6
27 x 20	10 ¹ / ₂ x 8
29 x 22,5	11 ¹ / ₂ x 8 ³ / ₄

Cromargan®	versilbert
stainless 18/10	silverplated
06.7540.6040	19.7540.6440
06.7542.6040	19.7542.6440
06.7543.6040	19.7543.6440



**Tablett, oval
CLASSIC**

serving tray, oval
plateau de service, ovale
bandeja, oval
vassoio, ovale

Cromargan® / stainless 18/10

Größe	size
cm	in.
59,5 x 46,7	23 ¹ / ₂ x 18 ¹ / ₂

06.7836.6040*

* Maße ohne Griffe / measures without handles



**Tablett, oval
BISTRO**

serving tray, oval
plateau de service, ovale
bandeja, oval
vassoio, ovale

stapelbar /
stackable

Cromargan® / stainless 18/10

Größe	size
cm	in.
51,6 x 39	20 ³ / ₄ x 15 ¹ / ₄

06.7681.6040



**Tablett, Gastronorm,
CLASSIC**

serving tray, Gastronorm
plateau de service, Gastronorm
bandeja, Gastronorm
vassoio, Gastronorm

GN ¹/₁, rechteckig /
GN ¹/₁, rectangular

Größe	size
cm	in.
53 x 32,5	20 ³ / ₄ x 12 ³ / ₄

Cromargan®	versilbert
stainless 18/10	silverplated
06.7849.6040	19.7849.6440



**Tablett Gastronorm
CLASSIC**

serving tray Gastronorm
plateau de service Gastronorm
bandeja Gastronorm
vassoio Gastronorm

rechteckig /
rectangular

Cromargan® / stainless 18/10

	Größe	size
	cm	in.
GN ¹ / ₁	53 x 32,5	20 ³ / ₄ x 12 ³ / ₄
GN ² / ₁	65 x 53	25 ¹ / ₂ x 20 ³ / ₄

06.7838.6040

06.7839.6040

Maße ohne Griffe / measures without handles



Tablett, Gastronorm

serving tray, Gastronorm
 plateau de service, Gastronorm
 bandeja, Gastronorm
 vassoio, Gastronorm

rechteckig /
 rectangular

Cromargan® / stainless 18/10

	Größe cm	size in.	
GN 1/2*	32,5 x 26,5	12 ³ / ₄ x 10 ¹ / ₂	06.7658.6040
GN 1/1**	53 x 32,5	20 ³ / ₄ x 12 ³ / ₄	06.7660.6040
GN 2/1	65 x 53	25 ¹ / ₂ x 20 ³ / ₄	06.7661.6040

* Passend auf alle GN 1/2 Rahmen / fitting on all GN 1/2 frames

** Passend auf alle GN 1/1 Rahmen und auf Plattenständer niedrig/hoch /
 fitting on all GN 1/1 frames and on tray stands low/high



Tablett Gastronorm BISTRO

serving tray Gastronorm
 plateau de service Gastronorm
 bandeja Gastronorm
 vassoio Gastronorm

GN 1/1, stapelbar, rechteckig /
 GN 1/1, stackable, rectangular

Cromargan® / stainless 18/10

Größe cm	size in.	
53 x 32,5	20 ³ / ₄ x 12 ³ / ₄	06.7680.6040

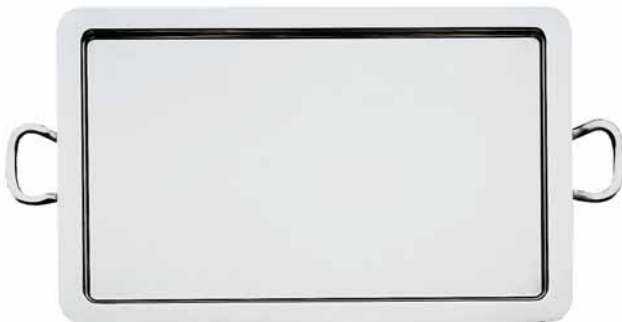

Tablett Gastronorm NEUTRAL

serving tray Gastronorm
 plateau de service Gastronorm
 bandeja Gastronorm
 vassoio Gastronorm

rechteckig /
 rectangular

Cromargan® / stainless 18/10

Größe cm	size in.	
GN 1/1	53 x 32,5	20 ³ / ₄ x 12 ³ / ₄
GN 2/1	65 x 53	25 ¹ / ₂ x 20 ³ / ₄

Maße ohne Griffe / measures without handles



Tablett, rechteckig, Gastronorm

serving tray, rectangular, Gastronorm
 plateau de service, rectangulaire, Gastronorm
 bandeja, rectangular, Gastronorm
 vassoio, rettangolare, Gastronorm

GN 1/1, stapelbar, rechteckig, schnittfest, spülmaschinenfest /
 GN 1/1, stackable, rectangular, resistant against cutting, dishwasher-safe

Kunststoff, Cromargan® - Griffe /
 high quality plastic, handle stainless 18/10

Größe	size
cm	in.
53 x 32,5	20 ³ / ₄ x 12 ³ / ₄

06.7683.6040



Tablett, rechteckig

serving tray, rectangular
 plateau de service, rectangulaire
 bandeja, rectangular
 vassoio, rettangolare

Cromargan® / stainless 18/10

Größe	size
cm	in.
40,1 x 29	15 ³ / ₄ x 11 ¹ / ₂
52,6 x 40,8	20 ³ / ₄ x 16

06.7269.6040

06.7271.6040

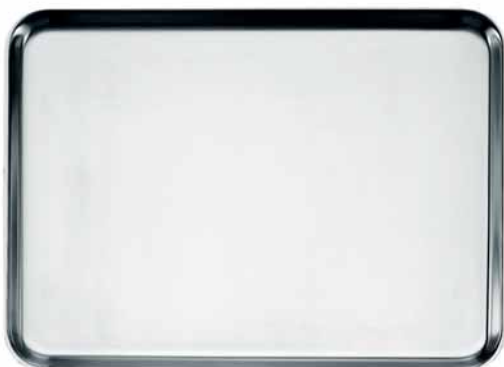

Tablett, rechteckig

serving tray, rectangular
 plateau de service, rectangulaire
 bandeja, rectangular
 vassoio, rettangolare

Cromargan® / stainless 18/10

Größe	size
cm	in.
28,5 x 21	11 ¹ / ₄ x 8 ¹ / ₄
33 x 26	13 x 10 ¹ / ₄
42,5 x 31,5	16 ³ / ₄ x 12 ¹ / ₂

06.7585.6040

06.7586.6040

06.7588.6040



**Tablett, rechteckig
 CLASSIC**

serving tray, rectangular
 plateau de service, rectangulaire
 bandeja, rectangular
 vassoio, rettangolare

Cromargan® / stainless 18/10

Größe	size
cm	in.
77,2 x 50,7	30 ¹ / ₂ x 20

06.7842.6040

Maße ohne Griffe / measures without handles



**Tablett, rechteckig
NEUTRAL**

serving tray, rectangular
plateau de service, rectangulaire
bandeja, rectangular
vassoio, rettangolare

Cromargan® / stainless 18/10

Größe	size
cm	in.
52,6 x 40,8	20 ³ / ₄ x 16

06.8444.6040

Maße ohne Griffe / measures without handles



**Käseglocke
NEUTRAL**

cheese dish
cloche à fromage
quesera
porta formaggio

Holzeinsatz Buche / beech wooden insert

	Ø	Ø	
	cm	in.	
passt in Tablett 7262 / fitting tray 7262	36,7	14 ¹ / ₂	60.3103.9990

Plexiglashaube / plastic cover

	Ø	Ø	
	cm	in.	
passt zu Einsatz 3103 / fitting insert 3103	34	13 ¹ / ₂	06.2864.6040



Abdeckhaube

cover for trays
cloche pour plateaux
campana para bandejas
coperchio adatto per vassoio

mit 2 seitlichen Eingriffen, passend für Tablett GN 1/1 ohne Griffe und Plattenständer niedrig/hoch /
with two side openings, fitting for trays GN 1/1 without handles and on tray stands low/high

Kunststoff glasklar, Griff verchromt /
high quality plastic, handle chrome plated

Größe	size
cm	in.
55,5 x 35 x 14,5	21 ³ / ₄ x 13 ³ / ₄ x 5 ³ / ₄

06.2937.6040



Kuchen-/Tortenplatte

cake plate
plat à tarte
plato tarta
piatto da torta

Cromargan® / stainless 18/10

Höhe	height	Ø	Ø
cm	in.	cm	in.
14,5	5 ³ / ₄	36	14 ¹ / ₄

06.4274.6040

Schönheit besteht. Auch aus guter Pflege.

Beauty endures.
And good care helps.



Alle WMF Besteckmodelle und Tafelgeräte sind aus edelsten Materialien für intensiven Gebrauch gefertigt. Auch die Bestecke mit perfekter Glanzversilberung sind spülmaschinenfest und unkompliziert zu pflegen. Doch was täglich zum vollen Einsatz kommt, ist hohen Belastungen ausgesetzt.

Damit WMF Produkte lange Zeit in vollem Glanz erstrahlen, empfehlen wir für Silber, Messing und Kupfer die richtige Pflege. Dazu gehören speziell für WMF entwickelte Pflegemittel, um ein Anlaufen von vornherein zu verhindern oder wieder zu entfernen.

Purargan® Silbertauchbad
Purargan® silver-dip-bath
Inhalt 5 Liter / cap. 175 oz.
14.2826.9990

Purargan® Silber-Pflegetuch
Purargan® silver polishing cloth
14.2822.9990

All WMF cutlery models and tableware are made of the finest materials for intensive usage. Even cutlery with superb high-shine silver plating is dishwasher-safe and easy to look after. But every item designed for everyday use has to withstand a great deal of wear and tear.

We want WMF products to keep looking their best for a long time, so we recommend proper care for silver, brass and copper. The care products specially developed for WMF are ideal for preventing tarnish and for removing it.

Purargan® forte, Pflegemittel
für Silber, Messing und Kupfer
Purargan® forte, silver, brass
and copper polish
Inhalt 1 Liter / cap. 35 oz.
14.2831.9990

Purargan® C, Pflegemittel für
Silber, Messing und Kupfer
Purargan® C, silver, brass and
copper polish
Inhalt 1 Liter / cap. 35 oz.
14.2828.9990

Artikel	Seite	Artikel	Seite	Artikel	Seite
"4 for you" - Löffel	102	Eiswanne GN ² / ₃	194	LEDlight Adapter GN ¹ / ₃	202
Abdeckhaube	251, 257	Eiswanne GN ² / ₄	194	LEDlight Adapter GN ² / ₃	201
Adapter für Elektroheizteil	226	Eiswasserkrug	150 - 151	LEDlight Adapter GN ² / ₄	202
Adapter GN ¹ / ₁	193	Eiszange	94	LEDlight Einheit	201
Adapter GN ¹ / ₃	193	Espresso-Set	110, 115	Légumier	140 - 141
Adapter GN ² / ₃	193	Essig-/Ölflasche	174	Leuchter	165 - 166
Adapter GN ² / ₄	193	Essig-/Ölgestell	173, 175, 181	Löffel "CultureCup"	114
Allround "CultureCup-Set"	111	Essig-/Öl-Menage	176 - 178	Löffel "KaffeeKultur"	102
Allround "KaffeeKultur-Set"	116	Essig-/Öl-Set	174	Marmeladegestell	149
Ascher	156	Ess-Stäbchen Ablage	103	Menage	144, 181
Asia-Set	180	Ess-Stäbchen Paar	103	Milchdispenser	238 - 239
Aufsatz GN ¹ / ₂	200	Ess-Stäbchen Set	103	Milchkaffee-Set	115
Aufsatz GN ¹ / ₃	200	Etagère	246 - 248	Milchkanne	122 - 123
Bargestell	150	Etagere GN ¹ / ₁	201	Milchkännchen	132
Beschriftunghalter V1 hinten	203	Flaschenteller	138	Milch-Zucker-Set	126, 128 - 131
Beschriftunghalter V2 vorne	203	Fleischgabel	92	Mokkaétagère	147, 247
Besteckablage	228 - 229	Früchtekorb	162, 249	Nudellöffel	93
Blumenvase	170 - 171	Gastronorm-Einsatz	224	Obstschale	164
Bowlenlöffel	96	Gebäck- und Servierzange	94	Petits Fours-Ständer	148 - 149
Brennstoffdose	228	Getränkekühler	135, 241	Plastik-Tischnummer	160
Brennstoffdosenhalter	227 - 228	Getränkekühlerständer	137	Platte	223
Brennstoffhalter Coffee Urn	232	Glas L mit Griff	113	Platte GN ¹ / ₁	196
Brotkorb	162 - 163	Glas LATTE (VPE 6 Stk.)	113	Platte GN ¹ / ₃	198
Brotkorb GN ¹ / ₁	199	Glas S (VPE 6 Stk.)	113	Platte GN ² / ₃	197
Brotkorb GN ¹ / ₂	200	Glasbehälter	119	Platte GN ² / ₄	197
Brotkorb GN ¹ / ₃	199	Glaskrug	240	Platte GN ³ / ₆	198
Brotkorb GN ² / ₃	199	Glasschale	248	Platten	251
Brotkorb GN ² / ₄	199	Gläser-Set	120	Plattenständer hoch	250
Brotmesser	98	Happy Spoon	101	Plattenständer niedrig	250
Brotschale	163	Heizelement	226 - 227	Platzteller	153
Brottschneidebrett GN ¹ / ₁	196	Heizelement Coffee Urn	232	Portions-Chafing Dish	217
Brücke GN ² / ₄	200	Honig-/Sahnespender	125	Portionsschöpfer	96
Buffetgestell	208 - 210	Hummergabel	95	Porzellanbehälter	114, 119
Buffet-Set	243 - 244	Hummerzange	95	Porzellan-Einsatz	222 - 223, 225
Butterkühler	141 - 143	Hygieneschutz	203	Porzellaneinsatz GN ¹ / ₄	203
Café au Lait-Set	116	Kaffeekanne	122 - 124	Porzellaneinsatz GN ¹ / ₆	202
Café Crème-Set	110, 115	Kaffeetablett	133, 252	Porzellaneinsatz GN ³ / ₆	202
Cappuccino-Set	110	Kakao-Set	110	Porzellan-Einsätze	223
Ceralien-/Saft-Set	243	Karaffe	242	Porzellanschale	133, 149
Cerealiendispenser	236 - 237	Kartenhalter	159	Porzellantasse M flach mit Griff	112
Chafing Dish	206 - 207, 214 - 218	Kartoffellöffel	97	Porzellantasse M hoch mit Griff	112
Chafing Dish - Besteck	92, 230	Kaviarkühler	145	Porzellantasse S mit Griff	112
Chillcup	146	Kaviarlöffel	100	Punchbowl	134
Coffee Urn	231	Kaviarmesser	101	Rahmen GN ¹ / ₁	192
Deckel mit Ausschnitt	114, 118	Konsole GN ¹ / ₃	195	Rahmen GN ¹ / ₃	192
Dessertgestell	143 - 145, 244 - 246	Konsole GN ¹ / ₆	195	Rahmen GN ² / ₃	192
Doppel-Espresso-Set	116	Konsole GN ¹ / ₆ mit Fuß	195	Rahmen GN ² / ₄	192
Dosenöffner	161	Konsole GN ² / ₄	196	Relish-Pickles-Gestell	150
Dressinglöffel	96	Konsole GN ³ / ₆	195	Rotweinwiege	139
Eierbecher-Set	155	Korkenzieher	161	Saftbar	240
Eierlöffel	97, 155	Krümelsammler	155	Saftdispenser	237 - 238
Einsatz für Chafing Dish	222	Kuchen-/Tortenplatte	257	Sahne-/Zucker-Set	118
Einzelartikel "KaffeeKultur"	117	Kühlakku	250	Sahnegießer	125
Eisgefäß	151 - 152	Kühlbehälter	249	Sahnekännchen	119
Eislöffel XL	102	Kühlelement	241	Sahnekännchen (VPE 6 Stk.)	118
Eisröhre	239	Käsedose	182	Sahne-Zucker-Set	127 - 128
Eisschale	146	Käseglocke	257	Salat-/Vorlegebesteck	92
Eisschaufel	97	Käsemesser	102		
Eiswanne GN ¹ / ₁	194	Latte Macchiato-Set	111, 115, 120		
Eiswanne GN ¹ / ₃	194	LEDlight Adapter GN ¹ / ₁	201		

Artikel	Seite	Artikel	Seite
Salatzange	93	Zuckerzange	94
Salz- und Pfeffergestell	173	Zwischensteg Induktion	229
Salz-/Pfeffer-Set	179		
Salzmühle / Pfeffermühle	172		
Salzstreuer / Pfefferstreuer	172		
Saucenlöffel	96		
Sauciere	140		
Schild mit Kette	232		
Schneckengabel	95		
Schneckenzange	95		
Senftopf	182		
Serviergestell	145, 246		
Serviertablett für Zucker	126		
Speisekartenhalter	160		
Steakbesteck	100		
Steakbesteck SOLID	99		
Steakmesser	100		
Steakmesser*	100		
Suppenmarmite	220 - 222		
Suppenschöpfer	97		
Suppenstation	221		
Tablett	111, 174, 248, 252 - 257		
Tablett Gastronorm	254 - 255		
Teeglas	120		
Teekanne	122 - 124		
Teelichtleuchter 3fl. klein	169		
Teesieb	121		
Teesieb-Behälter (VPE 6 Stk.)	121		
Teesieb-Einsatz	121		
Teller-/Schalengestell	244		
Tellercloche	153 - 154		
Tischnummer	160		
Tischnummern-Aufsteller	159		
Tischnummernständer	157 - 159		
Tischrestebehälter	155		
Toastständer	149		
Tortenheber	101		
Tortenmesser	101		
Tranchiergabel	99		
Tranchiermesser	98 - 99		
Universalschale	141, 163 - 164		
Universalzange	93 - 94		
Wein-/Sektkühler	135 - 136		
Weinkorb	139		
Weinkühler	136 - 137		
Weinkühlerständer	137 - 138		
Windlicht	167 - 168		
Vorlege-/ Aufschnittgabel	98		
Zahnstocher- und Süßstoffbehälter	133, 156, 181		
Zahnstocherbehälter	156		
Zigarrenabschneider	157		
Zitronenpresse	121		
Zuckerdose	122 - 124, 132		
Zuckerdosierer	125		
Zuckergestell	126 - 127		
Zuckerstangengefäß	132		

Article	Page	Article	Page	Article	Page
"4 for you" spoon	102	cover for trays	251, 257	LEDlight adapter GN 1/3	202
Adapter GN 1/1	193	creamer	119, 125, 132	LEDlight adapter GN 2/3	201
Adapter GN 1/3	193	creamer (unit 6 pcs.)	118	LEDlight adapter GN 2/4	202
Adapter GN 2/3	193			LEDlight unit	201
Adapter GN 2/4	193	decanter	242	lemon/orange squeezer	121
all-round "CultureCup Set"	111	dessert stand	143 - 145, 244 - 246	lid with cut-out	114, 118
all-round "KaffeeKultur Set"	116			lobster fork	95
ash tray	156	dressing ladle	96	lobster-crack	95
Asia set	180			meat fork	99
bar-relish dish	150	egg cup set	155	menage	144, 181
beverage cooler	135, 241	egg spoon	97, 155	menu stand	160
bowl for bread	162 - 163	espresso double set	116	milk dispenser	238 - 239
Bread basket GN 1/1	199	espresso set	110, 115	milk jug	122 - 123
Bread basket GN 1/2	200	etagere	246 - 248	mustard pot	182
Bread basket GN 1/3	199			name plate with chain	232
Bread basket GN 2/3	199	finger bowl	141, 164	oil and vinegar set	173 - 178, 181
Bread basket GN 2/4	199	flower vase	170 - 171	oil/vinegar bottle	174
Bread cutting board GN 1/1	196	frame	208 - 210	parmesan jar	182
bread knife	98	Frame GN 1/1	192	pasta serving spoon	93
bread-basket	162 - 163	Frame GN 1/3	192	pastry serving tongs	93 - 94
Bridge GN 2/4	200	Frame GN 2/3	192	pastry stand	147, 247
buffet set	243 - 244	Frame GN 2/4	192	petits-fours-stand	148 - 149
burner holder	227 - 228	fruit basket	162, 249	pie server	101
burner holder coffee urn	232	fruit bowl	164	plastic table number	160
butter cooler	141 - 143	fruit stand	164	plate and bowl stand	244
		glass bowl	248	plate cover	153 - 154
café au lait set	116	glass dish	119	Plate GN 1/1	196
café crème set	110, 115	glass L with handle	113	Plate GN 1/3	198
caffè Latte set	115	glass LATTE (unit 6 pcs.)	113	Plate GN 2/3	197
cake knife	101	glass pitcher	240	Plate GN 2/4	197
cake plate	257	glass S (unit 6 pcs.)	113	Plate GN 3/6	198
can opener	161	glass set	120	plate tray	153
candelabra	165	GN insert	224	platter	223
candle stick	166	GN porcelain insert	225	platters	251
cappuccino set	110	gravy boat	140	porcelain bowl 3-section	133, 149
card holder	159	gravy ladle	96	porcelain cup M high	
carving knife	98 - 99	happy spoon	101	with handle	112
caviar cooler	145	heating element	226 - 227, 232	porcelain cup M low	
caviar knife	101	holder for heating element	226	with handle	112
caviar spoon	100	honey/cream dispenser	125	porcelain cup S with handle	112
cereal dispenser	236 - 237	hygienic cover	203	porcelain dish	114, 119
Chafing Dish	206 - 207, 214 - 218	ice bucket	151 - 152	porcelain insert	222 - 223
chafing dish serving set	92, 230	ice cream bowl	146	porcelain insert GN 1/4	203
cheese dish	257	Ice pan GN 1/1	194	porcelain insert GN 1/8	202
cheese knife	102	Ice pan GN 1/3	194	potato spoon	97
chillcup	146	Ice pan GN 2/3	194	punch bowl	134
chopstick set	103	Ice pan GN 2/4	194	punch bowl ladle	96
chopstick stand	103	ice spoon XL	102	rack for utensils	228 - 229
chopsticks pair	103	ice tongs	94	red wine cradle	139
cigar cutter	157	ice tube	239	relish or condiment server	150
coaster for bottles	138	ice-shovel	97	salad serving tongs	93
cocoa set	110	insert for chafing dish	222	salad/buffet serving set	92
coffee pot	122 - 124	jam stand	149	salt and pepper set	179
coffee urn	231	juice bar	240	salt mill / pepper mill	172
connecting shelf	229	juice dispenser	237 - 238	salt shaker / pepper shaker	172
console GN 1/3	195	Label holder V1 rear	203	salt-pepper-set	173
console GN 1/6	195	Label holder V2 front	203	service tray	248
console GN 1/6 with feet	195	Latte Macchiato Set	111, 115, 120	serving fork	92, 98
console GN 2/4	196	LEDlight adapter GN 1/1	201	serving stand	145, 246
console GN 3/6	195			Serving stand GN 1/1	201
cooler	249				
cooling block	250				
cooling element	241				
cork-screw	161				

Article	Page
serving tray	111, 133, 252 - 257
serving tray for sugar	126
serving tray Gastronorm	254 - 255
set for cereal/juice dispenser	243
silent waiter	155
single items "KaffeeKultur"	117
snail fork	95
snail tweezer	95
solid alcohol	228
soup ladle	96 - 97
soup tureen	220 - 222
spoons "CultureCup"	114
spoons "KaffeeKultur"	102
stand for beverage cooler	137
stand for wine/champagne cooler	137 - 138
steak flatware	100
steak fork and knife SOLID	99
steak knife	100
steak knife*	100
sugar and creamer set	126 - 127
sugar and milk set	118, 128 - 131
sugar basin	122 - 124, 132
sugar dispenser	125
sugar pack holder	132
sugar server	126
sugar set	127
sugar tongs	94
table crumbler	155
table lamp	167 - 168
table lamp with glass	167
table number	159 - 160
table number stand	157 - 159
tea glass	120
tea pot	122 - 124
tea strainer	121
tea strainer holder (unit 6 pcs.)	121
tea strainer insert	121
tealight candle stick	169
toast rack	149
toothpick- and sweetener box-holder	133, 156, 181
toothpick-holder	156
top frame GN 1/2	200
top frame GN 1/3	200
tray	174, 253
tray stand high	250
tray stand low	250
universal dish	141, 163
water pitcher	150 - 151
vegetable dish and cover	140 - 141
wine / champagne cooler	135 - 136
wine cooler	137
wine-basket	139

Article	Page	Article	Page	Article	Page
Adaptateur GN 1/1	193	couteau à caviar	101	kit latte-macchiato	111, 115
Adaptateur GN 1/3	193	couteau à fromage	102	latte-macchiato-set	120
Adaptateur GN 2/3	193	couteau à pain	98	légumier et couvercle	140 - 141
Adaptateur GN 2/4	193	couteau à steak	100	louche	96
adaptateur pour plaque électrique	226	couteau à steak*	100	louche à potage	97
Adaptateur ampoule LED GN 1/1	201	couteau à tarte	101		
Adaptateur ampoule LED GN 1/3	202	couteau à viande	98 - 99	marmite à potage	220 - 222
Adaptateur ampoule LED GN 2/3	201	couvercle avec découpe	114, 118	menagère	144, 181
Adaptateur ampoule LED GN 2/4	202	couvert à salade/servir	92	menagère 2 pièces	173
alcool solidifié	228	couvert à steak	100	menagère 3 pièces	179
articles isolés "KaffeeKultur"	117	couvert à steak SOLID	99	moulin à sel / moulin à poivre	172
assiette de présentation	153	crémier	119, 125	moutardier	182
		crémier (UV 6 pc.)	118		
Bac à glace GN 1/1	194	cuiller "4 for you"	102	numéro de table	159 - 160
Bac à glace GN 1/3	194	cuiller à caviar	100	numéro de table en plastique	160
Bac à glace GN 2/3	194	cuiller à glace	97		
Bac à glace GN 2/4	194	cuiller à glace XL	102	ouvre-boîte	161
baguettes paire	103	cuiller à oeuf	97, 155		
bar à jus de fruit	240	cuiller à pommes de terre	97	panier à fruits	162, 249
bati	208 - 210	cuiller à punch	96	panier à pain	162 - 163
boîte de table	155	cuiller à sauce	96	panier à vin	139
bol à punch	134	cuillère à spaghetti	93	passoire	121
brique réfrigérante	250	cuillers "CultureCup"	114	passoire à thé	121
broc en verre	240	cuillers "KaffeeKultur"	102	pelle à gâteau	101
burette à vinaigre/huile	174			pince à escargots	95
		dessous de bouteille	138	pince à gâteau	93 - 94
Cadre GN 1/1	192	dispenseur de céréales	236 - 237	pince à glace	94
Cadre GN 1/3	192	dispenseur de jus	237 - 238	pince à homard	95
Cadre GN 2/3	192	dispenseur de lait	238 - 239	pince à salade	93
Cadre GN 2/4	192	distributeur à miel / crème	125	pince à sucre	94
cafetière	122 - 124			Planche à pain GN 1/1	196
carafe	242	élément réfrigérante	241	planche pour recipient	251
carafe à l'eau	151	ensemble buffet	243 - 244	plaque électrique	226 - 227, 232
carafe à l'eau	150 - 151	étagère	246 - 248	Plaque GN 1/1	196
cendrier	156	Etagère GN 1/1	201	Plaque GN 1/3	198
Chafing Dish	206 - 207, 214 - 218	étiquette avec chaîne	232	Plaque GN 2/3	197
				Plaque GN 2/4	197
chandelier	165 - 166	fourchette à escargots	95	Plaque GN 3/6	198
chandelier avec verrine	167 - 168	fourchette à homard	95	plat	223
chandelier bougie		fourchette à viande	92, 98 - 99	plat à tarte	257
à chauffe-plat	169			plateau	174, 253
chillcup	146	fromagère	182	plateau de service	111, 133, 248, 252 - 257
cloche à fromage	257			plateau de service Gastronom	254 - 255
cloche pour assiette	153 - 154	GN intérieur	224	plateau de service pour sucre	126
cloche pour plateaux	251, 257	GN intérieur en intérieur	225	Pont GN 2/4	200
coffee urn	231			porte brûleur	227 - 228
Console GN 1/3	195	happy spoon	101	porte brûleur coffee urns	232
Console GN 1/6	195	huilier-vinaigrier	173 - 178, 181	porte menu	160
Console GN 1/6 avec pied	195			porte numéro de table	157 - 159
Console GN 2/4	196	Incrustation porcelaine GN 1/4	203	porte petits fours	147 - 149, 247
Console GN 3/6	195	Incrustation porcelaine GN 1/6	202	porte-bouteille	139
Corbeille à pain GN 1/1	199	Incrustation porcelaine GN 3/6	202	porte-carte	159
Corbeille à pain GN 1/2	200	intérieur en porcelaine	222 - 223	porte-cure-dents	156
Corbeille à pain GN 1/3	199	intérieur pour chafing dish	222	porte-cure-dents et	
Corbeille à pain GN 2/3	199			recipient pour sucrettes	133, 156, 181
Corbeille à pain GN 2/4	199	kit "CultureCup" polyvalent	111	pot à lait	122 - 123
Corniche GN 1/2	200	kit "KaffeeKultur" polyvalent	116	pots à lait	132
Corniche GN 1/3	200	kit ASIA	180	pots à sucriers	132
coupe à fruits	164	kit baguettes	103	présentoir à assiette	145, 246
coupe à glace	146	kit cacao	110	presentoir a cereales/jus de fruit	243
coupe en porcelaine 3 parties	133, 149	kit café au lait	115 - 116		
coupe réfrigérante	249	kit café crème	110, 115		
coupe universelle	141, 163 - 164	kit cappuccino	110		
		kit espresso	110, 115		
coupe verre glasskin	248	kit espresso double	116		
coupe-cigares	157				

Article	Page
présentoir à gâteau	143 - 145, 244 - 246
presse-citron	121
Protection hygiénique	203
ramasse-brosse	155
rangement pour baguettes	103
réceptacle en porcelaine	114, 119
réceptacle en verre	119
refraîchisseur à beurre	141 - 143
refraîchisseur à caviar	145
saucière	140
saupoudreuse à sucre	125
seau à boisson	135, 241
seau à glace	151 - 152
seau à vin	137
seau à vin / champagne	135 - 136
service à relish	150
service à sucre	126
service à sucriers	127
service pots à lait / sucriers	118, 126 - 131
service pour chafing dish	92, 230
set à glass	120
set de coquetier	155
soucoupe pour passoire à thé (UV 6 pc.)	121
sucrier	122 - 124, 132
support couverts à servir	228 - 229
support pour bols à céréales	244
support pour confiture	149
Support pour inscription V1 arrière	203
Support pour inscription V2 avant	203
support pour pain grillé	149
support pour plaques bas	250
support pour plaques haut	250
support pour seau à boisson	137
support pour seau à champagne	137 - 138
tasse en porcelaine M haute avec anse	112
tasse en porcelaine M plate avec anse	112
tasse en porcelaine S avec anse	112
théière	122 - 124
tire-bouchon	161
traverse	229
tube à glace	239
Unité ampoule LED	201
vase à fleurs	170 - 171
verre à thé	120
verre L avec anse	113
verre LATTE (UV 6 pc.)	113
verre S (UV 6 pc.)	113

Articulo	Página	Articulo	Página	Articulo	Página
abrelatas	161	cucharas "CultureCup"	114	juego universal para el	
acumulador refrigerador	250	cucharas "KaffeeKultur"	102	"KaffeeKultur"	116
Adaptador GN 1/1	193	cucharon patatas	97	juego vasos	120
Adaptador GN 1/3	193	cuchillo carne	98 - 99		
Adaptador GN 2/3	193	cuchillo caviar	101	lechera	122 - 123
Adaptador GN 2/4	193	cuchillo pan	98	LEDluz Adaptador GN 1/1	201
adaptador para placa		cuchillo queso	102	LEDluz Adaptador GN 1/3	202
calentadora	226	cuchillo steak	100	LEDluz Adaptador GN 2/3	201
artículos diversos		cuchillo steak*	100	LEDluz Adaptador GN 2/4	202
"KaffeeKultur"	117	cuchillo tarta	101	LEDluz unidad	201
azucarero	122 - 124,	cuenco de porcelana		legumbreira con tapa	140 - 141
	132	3 divisiones	133, 149	linterna con cristal	167 - 168
azucarero para azúcar en cañas	132				
		depósito para chafing dish	222	Marco GN 1/1	192
bajoplató	153	depósitos de cristal	248	Marco GN 1/3	192
bandeja	111, 133,	dispensador de cereales	236 - 237	Marco GN 2/3	192
	174, 248,	dispensador de zumo	237 - 238	Marco GN 2/4	192
	252 - 257	dispensador leche	238 - 239	molinillo sal /	
bandeja con azucareros	126	dispensador miel / nata	125	molinillo pimienta	172
bandeja Gastronorm	254 - 255	dosificador azúcar	125	mostacero	182
botella de aceite/vinagre	174				
		elemento refrigerador	241	número de mesa	159 - 160
cafetera	122 - 124	enfriador caviar	145	número de mesa plástico	160
campana	154	enfriador para mantequilla	141 - 143		
campana con pomo	153	Etagère GN 1/1	201	pala para hielo	97
campana para bandejas	251, 257	etiqueta con cadena	232	pala para hielo XL	102
candelabro	165	exprimidor para limones	121	pala tarta	101
candelero	166			palillero	156
candelero lamparilla	169	florero	170 - 171	palillero y dispensador	
cazo ponche	96	frutero	162, 164,	de edulcorante	133, 156,
cazo porciones	96		246 - 247,		181
cazo salsa	96		249	panera	162 - 163
cazo sopa	97	frutero articulado	248	Panera GN 1/1	199
cenicero	156	fuelle	223, 251	Panera GN 1/2	200
cesta del pan	162 - 163			Panera GN 1/3	199
cesta vino	139	garrafa	242	Panera GN 2/3	199
Chafing Dish	206 - 207,	GN interior	224	Panera GN 2/4	199
	214 - 218	GN interior porcelana	225	pasarela	229
Coche hielo GN 1/1	194			pinza caracoles	95
Coche hielo GN 1/3	194	happy spoon	101	pinza de azucar	94
Coche hielo GN 2/3	194			pinza hielo	94
Coche hielo GN 2/4	194	interior colador té	121	pinza para ensalada	93
combustible	228	interior de porcelana	223	pinza para langostas	95
Consola GN 1/3	195	Interior de porcelana GN 1/4	203	pinza pasteles	93 - 94
Consola GN 1/6	195	Interior de porcelana GN 1/6	202	placa calentadora	226 - 227,
Consola GN 1/6 con pie	195	Interior de porcelana GN 3/6	202		232
Consola GN 2/4	196	interior porcelana	223	place calentadora	227
Consola GN 3/6	195			Plato GN 1/1	196
copa cóctel mariscos	146	jarra agua	150 - 151	Plato GN 1/3	198
copa helado	146	jarra de cristal	240	Plato GN 2/3	197
cortapuros	157	juego ASIA	180	Plato GN 2/4	197
cremera	119, 125,	juego azucarero	127	Plato GN 3/6	198
	132	juego azucarero / cremera	118,	plato tarta	257
cremera (UV 6 p.)	118		126 - 131	ponchera	134
cubierto ensalada/servir	92	juego cacao	110	porta aperitivos	150
cubierto servir chafing dish	92	juego café con leche	115 - 116	porta menus	160
cubierto steak	100	juego café-crème	110, 115	porta número de mesa	157 - 158
cubierto steak SOLID	99	juego capuchino	110	porta número de mesa	
cubiertos para chafing dish	230	juego de bufete	243 - 244	(sin grabación)	159
cubo bebida	135, 241	juego de palillos	103	porta número de mesa	
cubo hielo	151 - 152	juego espresso	110, 115	(sin número)	158
cubo vino	137	juego espresso doble	116	portabotella	138
cubo vino / champán	135 - 136	juego latte macchiato	111, 115,	portabotellas	139
cuchara "4 for you"	102		120	portacubos champán	137 - 138
cuchara caviar	100	juego palillos	103	portapastas	147 - 149,
cuchara huevos	97, 155	juego universal para el			247
cuchara pasta	93	"CultureCup"	111	portatarjetas	159

Articulo	Página	Articulo	Página
portatostadas	149	vaso S (UV 6 p.)	113
Protección higiénica	203	vaso té	120
Puente GN 2/4	200	vinagreras	173 - 178, 181
quesera	257		
recipiente	182, 249		
recipiente colador	121		
recipiente colador té (UV 6 p.)	121		
recipiente de cristal	119		
recipiente de porcelana	119, 222		
recipiente de procelana	114		
recipiente desperdicios	155		
recipiente sopa	220 - 221		
recipiente universal	141, 163 - 164		
recogemigas	155		
sacacorchos	161		
salsera	140		
servicio condimento	173, 179		
servicio de azúcar	126		
set 3 recipientes	144, 181		
set de huevera	155		
set para cereales/jugo	243		
set para zumos	240		
sopera para chafing dish	221 - 222		
soporte buffet	208 - 210		
soporte cubiertos servir	228 - 229		
soporte de bar	150		
Soporte para etiqueta V1			
parte trasera	203		
Soporte para etiqueta V2			
parte delantera	203		
soporte para mermelada	149		
soporte para palillos	103		
soporte para platos o fuentes	244		
soporte plato postre	143 - 145, 244 - 245		
soporte platos	145, 246		
soporte platos alto	250		
soporte platos bajo	250		
soporte platos postre	145, 246		
soporte quemador	227 - 228		
soporte quemador urna de café	232		
Suplemento GN 1/2	200		
Suplemento GN 1/3	200		
Tabla de cortar pan GN 1/1	196		
tapa con recorte	114, 118		
taza de procelana M			
alta con asa	112		
taza de procelana M			
baja con asa	112		
taza de procelana S con asa	112		
tenedor bogavante	95		
tenedor caracoles	95		
tenedor carne	92, 98 - 99		
tetera	122 - 124		
tubo para hielo	239		
urna de café	231		
vaso L con asa	113		
vaso LATTE (UV 6 p.)	113		

Articolo	Pagina	Articolo	Pagina	Articolo	Pagina
abriscatole	161	cucchiaino per caviale	100	piatto	251
Accessorio GN 1/2	200	cucchiaino per patate	97	piatto da torta	257
Accessorio GN 1/3	200	cucchiaino per uovo	97, 155	Piatto GN 1/1	196
Adattatore GN 1/1	193	cucchiaino per gelato	97	Piatto GN 1/3	198
Adattatore GN 1/3	193	cucchiaino per gelato XL	102	Piatto GN 2/3	197
Adattatore GN 2/3	193	cucchiaino per pasta	93	Piatto GN 2/4	197
Adattatore GN 2/4	193			Piatto GN 3/6	198
adattatore per piastra		dispenser cereali	236 - 237	piatto segnaposto	153
riscaldante	226	dispenser latte	238 - 239	pinza per aragoste	95
alcool solido	228	dispenser per succhi di frutta	237 - 238	pinza per ghiaccio	94
Alzata GN 1/1	201			pinza per lumache	95
alzata per frutta	164	elemento per il ghiaccio	241	pinza per zucchero	94
alzata porta dolci	147 - 149			pinza servire insalata	93
alzata portadolci	147, 247	forchetta aragosta	95	pinza servire per dolci	94
		forchetta da antipasto	92, 98	pinza universale	93 - 94
base	249	forchetta per lumache	95	Ponte GN 2/4	200
bicchiere da té	120	forchettone	99	ponticello	229
bicchiere L con maniglia	113	formaggiaria	182	porta formaggio	257
bicchiere LATTE (UV 6 p.)	113	fornello	227 - 228	porta frutta	246 - 248
bicchiere S (UV 6 p.)	113	fornello coffee urn	232	porta piattini per dessert	143 - 145, 244 - 246
bowl per punch	134	fruttiera	162, 249		
bricchetto per il latte	119			porta posante	228 - 229
bricchetto per il latte (UV 6 p.)	118	GN interno	224	porta rifiuti per tavolo	155
brocca di vetro	240	GN interno in porcellana	225	porta stuzzicadenti	156
brocca per acqua	150 - 151			porta stuzzicadenti e contenitore per dolcificante	133, 156, 181
		happy spoon	101	portacarta	159
caffettiera	122 - 124			portamenu	160
candeliere	165 - 166	inserto piatto chafing dish	222	portaoggetti per bacchette	103
candeliere lumino	169	Inserto porcellana GN 1/4	203	portapane	162 - 163
caraffa per aceto/olio	174	Inserto porcellana GN 1/6	202	portapiatti	145, 246
cavatappi	161	Inserto porcellana GN 3/6	202	portasalatini / olive	150
cestino per il pane	162 - 163	interno in porcellana	222 - 223	porta-toast	149
Cestino portapane GN 1/1	199	interno in vetro	248	posacenero	156
Cestino portapane GN 1/2	200			posate chafing dish	92, 230
Cestino portapane GN 1/3	199	lampa da tavola alta		posate da bistecca	100
Cestino portapane GN 2/3	199	c. paralum	168	posate da bistecca SOLID	99
Cestino portapane GN 2/4	199	lampa da tavola alta con paralume	167 - 168	posate servire insalata	92
cestino portavino	139	lattiera	122 - 123, 132	Protezione igienica	203
Chafing Dish	206 - 207, 214 - 218	LEDlight Adattatore GN 1/1	201		
		LEDlight Adattatore GN 1/3	202	raccogliatrice	155
chillcup	146	LEDlight Adattatore GN 2/3	201	ramaiolo	96 - 97
ciotola universale	141, 163 - 164	LEDlight Adattatore GN 2/4	202	recipiente di porcellana	114, 119
		LEDlight Unità	201	recipiente di vetro	119
coffee urn	231	legumiera con coperchio	140 - 141	rinfrescavino / spumante	136
colino per tè	121			rinfresca bevanda	135, 241
colino per tè con vaschetta		macinasale / macinapepe	172	rinfresca-burro	141 - 143
raccogliogocce	121	menage	173, 179	rinfresca-caviale	145
colonna per secchio spumante	137 - 138	ménage per tapenade	144, 181	rinfrescavino	137
coltellino per caviale	101	Mensola GN 1/3	195	rinfrescavino / spumante	135 - 136
coltello carne	98 - 99	Mensola GN 1/6	195		
coltello da bistecca	100	Mensola GN 1/6 con piede	195	salsiere	140
coltello da bistecca*	100	Mensola GN 2/4	196	secchiello da ghiaccio	152
coltello formaggio	102	Mensola GN 3/6	195	secchiello da ghiaccio	151 - 152
coltello pane	98	mestolino salsa	96	segnatavola	157 - 158
coltello torta	101			senapiera	182
contenitore per colino tè (UV 6 p.)	121	numero tavolo	159 - 160	set "CultureCup" completo	111
coperchio adatto per vassoio	251, 257	numero tavolo in plastica	160	set "KaffeeKultur" completo	116
coperchio con punto aperto				set ASIA	180
per cucchiaino	114, 118	oliera	173 - 178, 181	set bacchette	103
coppa gelato	146			set cacao	110
copripiatto con pomolo	153 - 154	paio bacchette	103	set café au lait	116
cremiera	125	pala da torta	101	set café crème	110, 115
cucchiai "CultureCup"	114	piastra riscaldante	226 - 227, 232	set café espresso doppio	116
cucchiai "KaffeeKultur"	102			set café latte	115
cucchiaino "4 for you"	102			set cappuccino	110
cucchiaino per bowl	96				

Articolo	Pagina
set da bicchieres	120
set da café espresso	110, 115
set girevole per succhi di frutta	240
set latte-macchiato	111, 115, 120
set lattiera zuccheriera	118, 126 - 131
set per bar	150
set per buffet	243 - 244
set per cereali/succhi	243
set portauovo	155
set zuccheriera	127, 132
singolo articolo "KaffeeKultur"	117
sottobottiglia	138
spremilimone	121
spuntasigari	157
Supporto etichetta V1 posteriore	203
Supporto etichetta V2 anteriore	203
supporto per confetture	149
supporto per piatti e coppe	244
supporto piatto alto	250
supporto piatto basso	250
Tagliere per pane GN 1/1	196
targhetta ad appoggio per numero tavolo	157, 159
targhetta con aggancio a catenella	232
tassa di porcellana M alta con maniglia	112
tassa di porcellana M bassa con maniglia	112
tassa di porcellana S con maniglia	112
tavoletta per il ghiaccio	250
teiera	122 - 124
telaio	208 - 210
Telaio GN 1/1	192
Telaio GN 1/3	192
Telaio GN 2/3	192
Telaio GN 2/4	192
tubo in acciaio	239
Vasca ghiaccio GN 1/1	194
Vasca ghiaccio GN 1/3	194
Vasca ghiaccio GN 2/3	194
Vasca ghiaccio GN 2/4	194
vaso da fiori	170 - 171
vassoietto tripartito portazucchero	133, 149
vassoio	111, 133, 174, 223, 248, 252 - 257
vassoio Gastronorm	254 - 255
vassoio per zucchero	126
versamiele / versalette	125
versavino	139
versazucchero	125
zuccheriera	122 - 124, 126, 132
zuppiera	220 - 221
zuppiera per chafing dish	221 - 222



Showrooms
Sales offices in Germany

Birkenfeld

Carl-Benz-Straße 10
75217 Birkenfeld
Tel. +49 (0) 72 31 / 4885 500
Fax +49 (0) 72 31 / 4885 590
info@wmf-professional.de

Frankfurt

Otto-Volger-Straße 5
65843 Sulzbach
Tel. +49 (0) 61 96 / 7500 07
Fax +49 (0) 61 96 / 7488 2
verkaufsbuero.sulzbach@wmf.de

Berlin

Am Borsigturm 15
13507 Berlin
Tel. +49 (0) 30 / 4966 511
Fax +49 (0) 30 / 4969 806
verkaufsbuero.berlin@wmf.de

Hamburg

Mönckebergstraße 13
20095 Hamburg
Tel. +49 (0) 40 / 2303 21
Fax +49 (0) 40 / 2368 7731
verkaufsbuero.hamburg@wmf.de

München

Sonnenstraße 19
85764 Oberschleißheim
Tel. +49 (0) 72 31 / 4885 500
Fax +49 (0) 72 31 / 4885 590
info@wmf-professional.de

Tochtergesellschaften
Subsidiaries

WMF in Österreich GmbH

Etrichgasse 13
6020 Innsbruck
Austria
Tel. +43 512 33 02-0
Fax +43 512 33 02-97
gastro@wmf.at

WMF Schweiz AG

Bernstraße 90
8953 Dietikon
Switzerland
Tel. +41 43 322 93 33
Fax +41 43 322 93 99
gastro@wmf.ch

WMF Española, S.A.

Avda. Llano Castellano, 15
28034 Madrid/Spain
Tel. +34 91 334 12 15/14
Fax +34 91 729 32 22
hotel@wmf.es

WMF France S.A.R.L.

13/15 rue Nicolas Ledoux
94000 Creteil
France
Tel. +33 1 49 80 80 10
Fax +33 1 49 80 70 90
info@wmf.fr

WMF United Kingdom Ltd.

31 Riverside Way
Uxbridge
Middlesex UB8 2YF
United Kingdom
Tel. +44 1895 816 100
Fax +44 1895 816 105
tableware@wmf.uk.com

WMF Japan Corp. K.K.

23-5, Nishishinbashi 3-Chome Minato-ku
Tokyo 105-0003
Japan
Tel. +81 3 5408 3301
Tel. +81 3 5408 3302 (hotel)
Fax +81 3 5408 3311
info@wmf-japan.co.jp
wmfj@wmf-japan.co.jp

WMF Shanghai Co. Ltd.

1101-1102 International
Capital Plaza
1318 North SiChuan Road
Hongkou District
Shanghai 200086
P.R. China
Tel. +86 21 5515 5212
Fax +86 21 5515 5220
info@wmf-china.com

proHeq GmbH
WMF Professional
Carl-Benz-Straße 10 · 75217 Birkenfeld · Germany
Phone: +49 7231 4885 500 · Fax: +49 7231 4885 590
info@wmf-professional.de · www.wmf-professional.de

63.8080.9990 · Printed in Germany 03.17

Alle Angaben sind unverbindlich. Druckfehler, Änderungen und Irrtum für den gesamten Inhalt vorbehalten.
All data without obligation. The entire content is subject to misprints, changes and errors.



Print  compensated
Id.-No. 1761319
www.bvdm-online.de

